

WRENCHHEAD MECHANICAL
 3135 4 ST
 NISKU, ALBERTA. T9E-8L1
 Phone: 780-436-9570 Fax: 780- -

INVOICE

34385

Org. Est. # 051132

INVOICE

Date: 02/04/2021

CHEMCO ELECTRICAL-HEAVY DUTY

3135-4th ST
 NISKU, AB T9E-8L1
 Office 780-436-9570 -- Cellular 780-231-0871

2006 Peterbilt - 335 UNIT#U125-1 - CATERPILLAR C-7 ADEM /

Lic # :
 Unit # : PT-0198
 VIN # : 2NPLLD9X2 6M660198
 Engine Hrs In : 473.6
 Odometer In : 209360
 Engine Hours Out : 473.6

Part Description / Number	Qty	Sale	Ext	Labor Description	Ext
LED LICENCE LAMP-STK 434WD	1.00	7.22	7.22	(1) GET STEEL RIVER READY ** REMOVE PLATINUM DECALS. INSTALL STEEL RIVER DECALS. COMPLETE STEEL RIVER CHECK LIST. REPAIR LIGHTS, ADJUST TURRET STOPS, SERVICE ENGINE UNIT NO LONGER REQUIRED BY STEEL RIVER. REMOVE STEEL RIVER DECALS. PARK IN LINE UP.	747.50
HEADLIGHT BULB-STK 9007	1.00	6.17	6.17		
SYNTHETIC 5W40 OIL-STK 5W40SYN	27.00	5.50	148.50		
OIL FILTER-STK LF667	1.00	11.73	11.73		
FUEL FILTER-STK FF5324	1.00	13.86	13.86		
FUEL FILTER-STK FF105D	1.00	6.82	6.82		
PETE CABIN AIR FILTER-STK 23-15619	1.00	27.79	27.79		
POWER STEERING FILTER-STK 87904M	1.00	25.21	25.21		
AIR FILTER-ORDER AF4878	1.00	41.85	41.85		
BEACON LIGHT BULB-ORDER 7400	1.00	12.02	12.02		
LOW BEAM HARNESS-ORDER UP-34207	1.00	7.45	7.45		
Shop Supplies			37.38		

Org. Estimate 884.75 Revisions 0.00 Current Estimate 884.75

Labor:	747.50
Parts:	346.00
SubTotal:	1,093.50
Tax:	54.68
Total:	1,148.18
Bal Due:	\$1,148.18

STK-285

[Payments -]
 Vehicle Received: 1/27/2021

GST#865376503RT0001
 Signature _____ Date _____

WRENCHHEAD MECHANICAL

3135 4 ST
NISKU, ALBERTA. T9E-8L1
Phone: 780-436-9570 Fax: 780- -

REPAIR ORDER #

034385

Org. Est. # 051132

REPAIR ORDER - RO

Scheduled : 01/20/2021 09:15 AM

Print Date : 1/20/2021

CHEMCO ELECTRICAL-HEAVY DUTY

3135-4th ST

NISKU, AB T9E-8L1

Office 780-436-9570 --- Cellular 780-231-0871

Cust ID :

Last Service : 6/17/2020

Previous Odom : 205724

2006 Peterbilt - 335 UNIT#U125-1 - CATERPILLAR C-7 ADI

Lic # : - ALBERTA

Unit # : PT-0198

VIN # : 2NPLLD9X2 **6M660198**

MFG Date : 5/3/2017

Current Odom : 0

Elapsed : 0

<i>Labor Requested / Part SubTotal</i>	Extended
--	-----------------

(1) GET STEEL RIVER READY

650.00

Shop Supplies

Parts Subtotal 0.00

32.50

Parts: 0.00
Labor: 650.00

Supplies: 32.50

Tax: 34.13

Total: 716.63
Balance: 716.63

TEARDOWN ESTIMATE: I understand that my vehicle will be reassembled within ___ days of the date shown above if I choose not to authorize the service recommended. All Parts removed will be discarded unless instructed otherwise: Save all Parts ____. NOT RESPONSIBLE FOR LOSS OR DAMAGE TO MY VEHICLE OR ARTICLES LEFT IN VEHICLES IN CASE OF FIRE, THEFT OR ANY OTHER CAUSE. ALL VEHICLES LEFT MUST HAVE OWN INSURANCE. ANY VEHICLES LEFT OVER 30 DAYS WITHOUT CONSENT WILL BE PROPERTY OF WRENCHHEAD MECHANICAL.

Authorized By _____ Date _____ Time _____

Technician Work Sheet Service Writer : GLAZIER, RUSSELL

Print Date: 1/20/2021

2006 Peterbilt - 335 UNIT#U125-1

Hat # :

Repair Order #

VIN # : 2NPLLD9X2 6M660198

Color :

034385

Engine : CATERPILLAR C-7 ADEM A4/ACERT EPA

Location :

Lic # :

Lic. State : ALBERTA

CHEMCO ELECTRICAL-HEAVY DUTY

Schedule : 1/20/21 9:15 A.M.

Office 780-436-9570 --- Cellular 780-231-0871

Promised Date : 1/20/21 5:00 P.M.

Inspection Date : 5/03/17

Status :

Last Service : 6/17/20

Unit # : PT-0198

Current Odometer : 0

Trans :

Previous Mileage : 205,724

Brakes :

Elapsed Mileage : 0

Manufacture Date : 5/03/17

Labor Description

Charged Hours

<input checked="" type="checkbox"/> (1) GET STEEL RIVER READY	10.00
Technician: <none>	

OUT ODOMETER : 209360

Total Hours Charged : 10.00

Hours out: 0.00

Tech Notes

Crane Good UNTIL Aug 2021

CRANE CERT GOOD UNTIL MAR 2021

Unit #: PT-0198

S/N:

Odometer: 209360

Hours: 473.6

Lab#	Repair Description	Date	Location	Tech Name	Hours
	BRING UNIT IN / START CHECK OVER / COMPILE LIST ORDER PARTS / INSTALL FIRE EXT & SPILL KIT REMOVE PLATINUM DECALS / INSTALL NECTAR DECAL INSTALL STEEL RIVER DECALS	JAN 20/21	SHOP	DARRYL M	3
	REPAIR HEADLIGHT WIRING (LS) REPLACE BULB / REPLACE LICENSE PLATE LIGHT ASSY / REPLACE LEAKING AIR TANK DRAIN VALVE	JAN 22/21	SHOP	DARRYL M	1.5
	DIAGNOSE TURRET ROTATE STOPS COMPLAINT TIGHTEN / ADJUST STOPS / TEST / WORKS GOOD	JAN 20/21 JAN 21/21	SHOP SHOP	DARRYL M DARRYL M	1.5 1
	REPAIR BEACON LIGHT / STOP WORK UNIT MIGHT NOT BE NEEDED NOW				
	MOVE UNIT OUTSIDE UNTIL DECISION IS MADE	JAN 22/21	SHOP	DARRYL M	.5
	UNIT NOT GOING / REMOVE STEEL RIVER DECALS				
	Start unit Service oil Fuel air filter	Feb 3/21	Shop	chase v	3
	P/S and Grease INSTALL SERVICE DECAL / MOVE UNIT OUT / REMOVE STEEL RIVER DECALS	FEB 4/21	SHOP	DARRYL M	1

Parts

Mechanic ID:

Mechanic Signature: _____

Qty.	Part #	Description	STK/ORD	Qty.	Part #	Description	STK/ORD
1		SPILL KIT	/	1	AF4878	ENGINE AIR FILTER	✓
1	# 43893	20# FIRE EXT	/	1	B7904M	P/S FILTER	✓
1	9007	HEAD LIGHT BULB	/	1	7400	BEACON BULB	✓
1	434WD	LICENSE PLATE BULB	/	1	23-15619	CABIN AIR FILTER	✓
1		DRAIN COCK	/	1		HEADLIGHT PIGTAIL	
1	LF667	OIL FILTER	/	1	B7904M	P/S FILTER	✓
1	FF5324	FUEL FILTER	/	1	AF4878	ENGINE AIR FILTER	✓
1	BF957D	FUEL FILTER	/	27L	5W40	ENGINE OIL	✓
1		OIL SAMPLE JAR	/				

	Labour Requisition	MTE-0131
--	--------------------	----------

UNIT #:	PT-0198	ODOMETER:	209360	ENGINE HOURS:	473.6	DATE:	Jan 20/21
---------	---------	-----------	--------	---------------	-------	-------	-----------

ITEM	REPAIR DESCRIPTION	QUOTED HOURS	ACTUAL HOURS
X	GET STEEL RIVER READY AS PER LIST		
Done	BEACON BULB OUT REPLACE		
Done	LS HEADLIGHT OUT REPLACE BULB + PIGTAIL		
X	DASH LIGHTS OUT REPLACE BULBS		
X	CRUISE CONTROL NOT WORKING DIAGNOSE		
Done	REMOVE PLATINUM DECALS		
	REMOVE PLATINUM GPS/DRIVER ID ?		
X	WASH INSIDE + OUT / TAKE PICS		
Done	ENGINE SERVICE DUE IN 26 HRS		
X	ROUGH INSTALL 2WAY / NO RADIO		
Done	LICENSE PLATE LIGHT OUT REPLACE		
NO	REMOTE CONTROLS FOR PICKER (QUOTE)		
X	STRAP RATCHETS SEIZED		
	MULTIPLE BUCKET OIL SEEPS (NOT DRIPPING) X		
X	HYD LEAK @ HYD FILTER AREA		
Done	AIR LEAK @ TANK DRAW VALVE REPLACE		
Done	BOOM ROTATE STOP ISSUE		

Technician (Print Name)

Technicians Signature

06-335 660198

chemco	Parts Requisition	MTE-0130
---------------	--------------------------	-----------------

UNIT #:	PT-0198	UNIT TYPE/DESCRIPTION:	
WO# 34385	ODOMETER:	ENGINE HOURS:	DATE: JAN 20/21

ITEM	QTY	PART#	DESCRIPTION	IN STOCK	ORDER
✓	1	☐	20# FIRE EXT		✗
✓	1		SPILL KIT	✓	
✓	1		2 WAY ANTENNA + CABLE	✓	
✓	1		2 WAY MOUNT	✓	
✓	1		2 WAY POWER CORD	✓	
✓	1	7400	BEACON BULB		✗
✓	1	9007	HEADLIGHT	✓	
			DASH LIGHT BULBS	✓	
✓	1	704822EA	61501EA 434W0 LICENSE PLATE LIGHT		✗
✓	1	LF667	OIL FILTER	✓	
✓	1	FF5324	FUEL FILTER	✓	
✓	1	AF4878 AF4878	ENGINE AIR FILTER		✗
✓	1	87904M	P/S FILTER		✗
✓	-1	3703	AIR TANK DRAIN VALVE	✓	
✓	1	FF105	FUEL FILTER	✓	
✓	1	23-15619	CABIN FILTER	✓	
✓	1		LS HEADLIGHT BULB PIGTAIL		✗

DM
Technician (Print Name)

Technicians Signature



PT-0198

REQUISITION FOR MATERIAL ORDER

Special Instructions:

Requisition Num: Lorne Platinum-001-ER-00021

Sheet 1 of 1

Activity Num: Lorne Platinum-001-NA-NA

Activity Name: _____

Ship To: (if other than standard jobsite location)

Project Name: Lorne Platinum

Dropped off at HQ

Project Location: _____

Date Required: 20-Jan-21

ITEM	QTY	UNIT	DESCRIPTION OF MATERIAL	SUPPLIER
1	1	ea	Unit 125-1 Kuckle Boom Truck, Returned for Steel River Rental.	
Extra Info			Shipped Qty	

PRE-DELIVERY INSPECTION

OK N/A

Quantity Matches Requisition

Model/Part# Match Requisition

Overall Condition/Cleanliness

Function

Accessories/Leads/Loose Parts

Calibration Valid/Cert Included

Fuel

Openings Water Proof

Comment: _____

Inspector Date

Requisitioned By _____ Date _____

Approved By _____ Date _____

Owner's Approval _____ Date _____



STEEL RIVER
EQUIPMENT

Equipment Checklist

Unit # :	PT-0198	Serial # :	2NPLLD9X26M660198	Date :	JAN 2021
Make :	PETERBILT	Model :	335	Location :	NISKU
Technician :		Hour Meter	437	Last Service Hours	

Inspection Status

Ready for Work

Visual Inspection Of :

Checklist Item	Yes	No	N/A	Comments	Checklist Item	Yes	No	N/A	Comments
1. Operator Compartment & Cab Condition	<input checked="" type="checkbox"/>				16. Fire Extinguishers (20 lbs)	<input checked="" type="checkbox"/>			
2. Instrument Panel, Warning Labels etc.	<input checked="" type="checkbox"/>				17. All Belts & Pulleys (tighten if req.)	<input checked="" type="checkbox"/>			
3. Frame, Cover, Handrails, etc.	<input checked="" type="checkbox"/>				18. All Hoses, Fittings, Lines for Wear	<input checked="" type="checkbox"/>			
4. Wiper Blades & Arms	<input checked="" type="checkbox"/>				19. Machine Free of Leaks				
5. Cab Structure	<input checked="" type="checkbox"/>				20. Fluid Levels	<input checked="" type="checkbox"/>			
6. Air Intake & Exhaust System	<input checked="" type="checkbox"/>				21. Articulation Pivot Bearings			<input checked="" type="checkbox"/>	
7. Positive Air Shutoff					22. Pins & Bushings	<input checked="" type="checkbox"/>			
8. Battery Compartment & Fuse Panel					23. Machine Washed & Free of Organics				
9. Radiator & Cooler Cores & Hoses	<input checked="" type="checkbox"/>				24. Machine Greased				
10. Tires & Wheels	<input checked="" type="checkbox"/>				25. Driveline & U-Joints	<input checked="" type="checkbox"/>			
11. Tracks & Rollers			<input checked="" type="checkbox"/>		26. Product Link Antenna			<input checked="" type="checkbox"/>	
12. Fuel Tank & Lines	<input checked="" type="checkbox"/>				27. Track Shovel &/or Bucket Wrenches			<input checked="" type="checkbox"/>	
13. Hydraulic Tank (incl. strainer) & Lines	<input checked="" type="checkbox"/>				28. Operation Manual & Log Book	<input checked="" type="checkbox"/>			
14. Hydraulic Cylinders	<input checked="" type="checkbox"/>				29. Component Services	<input checked="" type="checkbox"/>			
15. Seat Belts / Seats (exp. date)	<input checked="" type="checkbox"/>				30. Fuel Level				



Equipment Checklist

Operational Check Of :

Checklist Item	Yes	No	N/A	Comments	Checklist Item	Yes	No	N/A	Comments
1. Ether Starting System			✓		8. Directional & Speed Control Operation	✓			
2. Travel Alarm	✓		✓		9. Braking System (service & park)	✓			
3. Radio	✓				10. Implement Lever & Control Linkage	✓			
4. Lights & Horn	✓				11. Hydraulic Control Functions	✓			
5. Heating & Air Conditioner	✓				12. Block Heater & Espar/Webasto				
6. Engine Start, Running & Shutdown	✓				13. Ground Control System / <i>Brigade</i>			✓	
7. Electrical Starting & Charging System	✓				14. Test Accumulators			✓	

Comments:

Signatures:

Technician Name(s)

Dept. Approval

Photo's Required: All four corners, Inside Cab, Hour Meter

WRENCHHEAD MECHANICAL

3135 4 ST
 NISKU, ALBERTA. T9E-8L1
 Phone: 780-436-9570 Fax: 780- -

INVOICE

39370

Org. Est. # 056137

INVOICE

Printed Date: 10/10/2022 Work Completed: 10/10/2022

CHEMCO ELECTRICAL-HEAVY DUTY

3135-4th ST
 NISKU, AB T9E-8L1
 Office 780-436-9570 -- Cellular 780-231-0871

2006 Peterbilt - 335 UNIT#U125-1 - CATERPILLAR C-7 ADEM /
 Lic # : Odometer In : 210780
 Unit # : PT-0198
 VIN # : 2NPLLD9X2 6M660198

Part Description / Number	Qty	Sale	Ext	Labor Description	Ext
1/4"X1/8" PIPE BUSHING -STK 110-BA	1.00	0.36	0.36	(1) DIAGNOSE OIL IN COOLANT ** SEE TECH SHEET **	2,470.00
1/8" 90 NPT EXT STREET ELBOW -STK 115-A	1.00	0.79	0.79		
BELT -ORDER D84-1000-6082175	1.00	78.94	78.94		
OIL FILTER-STK LF667	1.00	11.74	11.74		
OIL COOLER -ORDER OR-8839	1.00	712.41	712.41		
HOSE -ORDER 205-1332	1.00	59.77	59.77		
GASKET -ORDER 7C-7431	1.00	13.54	13.54		
STUD -ORDER 418-6781	2.00	42.85	85.70		
RING -ORDER 4F-7391	1.00	3.82	3.82		
ORING -ORDER 464-0509	1.00	7.35	7.35		
LOCK NUT -ORDER 9X-6620	4.00	11.80	47.20		
STUD -ORDER 418-6781	2.00	50.51	101.02		
GASKET -ORDER 272-1956	6.00	6.29	37.74		
1/4 FUEL LINE/FT-STK 65126	3.50	0.89	3.12		
GASKET-AFM DEVICE -STK 2866636	1.00	18.38	18.38		
SYNTHETIC 5W40 OIL-STK 5W40SYN Shop Supplies	27.00	7.62	205.74 100.00		

WRENCHHEAD MECHANICAL
 3135 4 ST
 NISKU, ALBERTA. T9E-8L1
 Phone: 780-436-9570 Fax: 780- -

INVOICE

39370

Org. Est. # 056137

INVOICE

Printed Date: 10/10/2022 Work Completed: 10/10/2022

CHEMCO ELECTRICAL-HEAVY DUTY

3135-4th ST
 NISKU, AB T9E-8L1
 Office 780-436-9570 -- Cellular 780-231-0871

2006 Peterbilt - 335 UNIT#U125-1 - CATERPILLAR C-7 ADEM /
 Lic # : Odometer In : 210780
 Unit # : PT-0198
 VIN # : 2NPLLD9X2 6M660198

Part Description / Number	Qty	Sale	Ext	Labor Description	Ext
---------------------------	-----	------	-----	-------------------	-----

Org. Estimate 359.52 Revisions 0.00 Current Estimate 359.52

Labor:	2,470.00
Parts:	1,487.62
SubTotal:	3,957.62
Tax:	197.88
Total:	4,155.50
Bal Due:	\$4,155.50

STK-340

[Payments -]

Vehicle Received: 9/26/2022

Customer Number : 1561

GST#865376503RT0001

Signature _____ Date _____

WRENCHHEAD MECHANICAL

3135 4 ST
NISKU, ALBERTA. T9E-8L1
Phone: 780-436-9570 Fax: 780- -

REPAIR ORDER #

039370

Org. Est. # 056137

REPAIR ORDER - RO

Scheduled : 09/26/2022 08:54 AM

Print Date : 9/26/2022

CHEMCO ELECTRICAL-HEAVY DUTY

3135-4th ST
NISKU, AB T9E-8L1
Office 780-436-9570 --- Cellular 780-231-0871
Cust ID :
Last Service : 6/20/2022

2006 Peterbilt - 335 UNIT#U125-1 - CATERPILLAR C-7 ADI

Lic # : - ALBERTA

Unit # : PT-0198

VIN # : 2NPLLD9X2 **6M660198**

MFG Date : 5/3/2017

Previous Odom : 210779

Current Odom : 0

Elapsed : 0

<i>Labor Requested / Part SubTotal</i>	Extended
(1) DIAGNOSE OIL IN COOLANT	325.00
Shop Supplies	16.25
Parts Subtotal	0.00

Parts: 0.00 Supplies: 16.25 Tax: 17.06 Total: 358.31
Labor: 325.00 Balance: 358.31

TEARDOWN ESTIMATE: I understand that my vehicle will be reassembled within ___ days of the date shown above if I choose not to authorize the service recommended. All Parts removed will be discarded unless instructed otherwise: Save all Parts ____. NOT RESPONSIBLE FOR LOSS OR DAMAGE TO MY VEHICLE OR ARTICLES LEFT IN VEHICLES IN CASE OF FIRE, THEFT OR ANY OTHER CAUSE. ALL VEHICLES LEFT MUST HAVE OWN INSURANCE. ANY VEHICLES LEFT OVER 30 DAYS WITHOUT CONSENT WILL BE PROPERTY OF WRENCHHEAD MECHANICAL.

Authorized By _____ Date _____ Time _____

Technician Work Sheet Service Writer : GLAZIER, RUSSELL

Print Date: 9/26/2022

2006 Peterbilt - 335 UNIT#U125-1

Hat # :

VIN # : 2NPLLD9X2 6M660198

Color :

Repair Order #

Engine : CATERPILLAR C-7 ADEM A4/ACERT EPAI Location :

039370

Lic # :

Lic. State : ALBERTA

CHEMCO ELECTRICAL-HEAVY DUTY

Schedule : 9/26/22 9:00 A.M.

Office 780-436-9570 --- Cellular 780-231-0871

Promised Date : 9/26/22 5:00 P.M.

Inspection Date : 5/03/17

Status :

Last Service : 6/20/22

Unit # : PT-0198

Current Odometer : 0

Trans :

Previous Mileage : 210,779

Brakes :

Elapsed Mileage : 0

Manufacture Date : 5/03/17

Labor Description

Charged Hours

<input checked="" type="checkbox"/> (1) DIAGNOSE OIL IN COOLANT	5.00
Technician: SHAW	

OUT ODOMETER : 210 790

Total Hours Charged : 5.00

Hours out: 0.00

Tech Notes

Unit #: PT-0199 S/N:

Odometer: 210 780

Hours:

Lab#	Repair Description	Date	Location	Tech Name	Hours
	Diagnosed sludge in coolant pulled bracketric, turbo, Alt/intercooler & oil cooler	Sept 26/22	Shop	AJLW	10
	Cleaned up parts to get ready for reassemble	Sept 27/22	Shop	AJLW	3
	Installed o/r cooler & torqued bolts, tried to remove broken turbo flange bolts on manifold & didn't work end up removing manifold	Oct 4/22	Shop	AJLW	9
	Cleaned exhaust manifold gasket surface on manifold & head, installed manifold & turbo & oil piping with reservoir new oil filter flushed coolant system with water & detergent, tested filled up with coolant, pure concentrated	OCT 6/22	SHOP	ANDREW S	10
		OCT 6/22	SHOP	DANNYL M	2
	REMOVE BROWN TURBO MOUNTING STUDS	OCT 5/22	SHOP	DANNYL M	5

Parts

Mechanic ID:

Mechanic Signature:

Qty.	Part #	Description	STK/ORD	Qty.	Part #	Description	STK/ORD
				13.5L		13.5 L coolant	
1	LF667	LF667 oil filter					
1	1784-1000-6080175						
1	4640509	ORing S					
1	286636	turbo gasket					
1	4F7391	ORing					
6	2721956	exhaust manifold gaskets					
1	2051332	turbo oil feed line					
1	51550093	Belt					

Special Instruction

102170458

Torque Procedure for the OR-8839 Oil Cooler Core As

SMCS Code: 1378

Engine Commercial with Mechanical Unit
Injection
3126

Engine Machine with Mechanical Unit
Injection
3126

Engine Truck with Mechanical Unit
Injection
3116

Engine
3116
3126
3126 and 3126B
3126B

Engine Commercial with Mechanical Unit
Injection
3116

Engine Machine with Mechanical Unit
Injection
3116

Engine Machine
3126

Engine Truck with Hydraulic Electronic
Unit Injection (HEUI)
3116
3126
3126B

Engine
3116
3126
3126B
3126E

Table of Contents

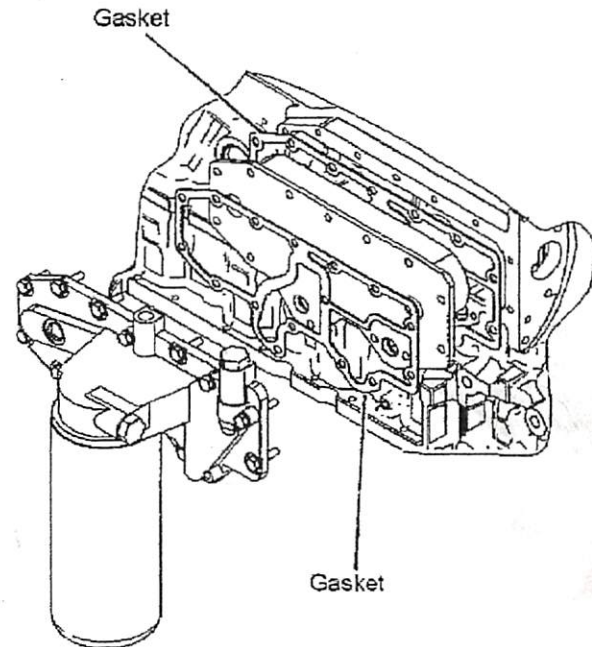

Illustration 1

g01102108

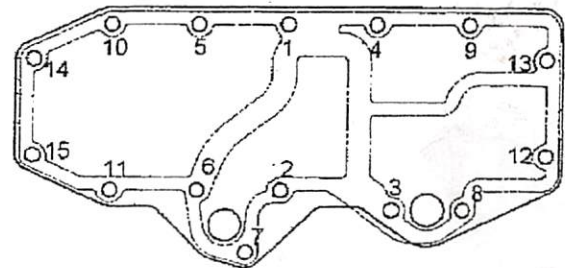

Illustration 2

g01100476

Do not use any sealant. Refer to illustration 2 for the bolt tightening sequence for the oil cooler.

3. Tighten bolts (4) in a numerical sequence to a torque of 15 N·m (11 lb ft). Tighten bolts (4) in a numerical sequence to a torque of 28 N·m (21 lb ft).

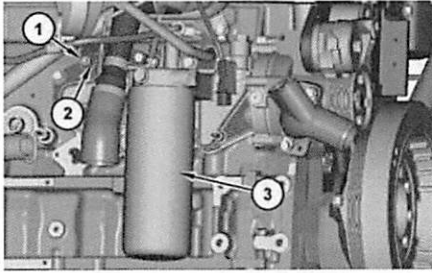

Illustration 4

g01258099

4. Install oil filter (3). Install the hose assembly and bracket (2). Install nuts (1).
5. Fill the cooling system with coolant. Refer to Operation and Maintenance Manual, "Cooling System Coolant (ELC) - Change".
6. Fill the engine with oil. Refer to Operation and Maintenance Manual, "Engine Oil and Filter - Change".

End By:

- a. Install the turbocharger. Refer to Disassembly and Assembly, "Turbocharger - Install".

C7S1-UP, C7W1-UP, RMF1-UP

PPT-1066C145
2022/10/04
15:34:40-06:00
i02514948
© 2022 Caterpillar Inc.
Caterpillar:
Confidential Green

PPT-1066C145
2022/10/04
15:35:26-06:00
REN9707
© 2022 Caterpillar Inc.
Caterpillar:
Confidential

SMCS - 1306, 1378

i02514948

Installation Procedure

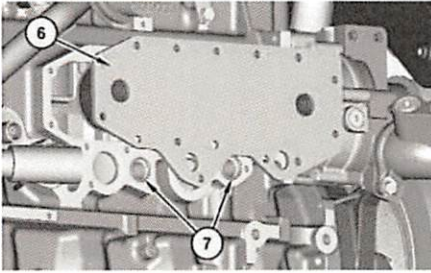

Illustration 1

g01258137

Note: Check O-ring seals for wear or for damage. If necessary, replace the O-ring seals.

1. Install O-ring seals (7). Install oil cooler (6) and the gasket.

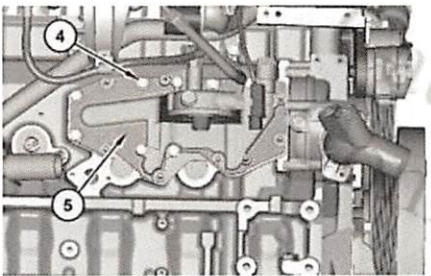
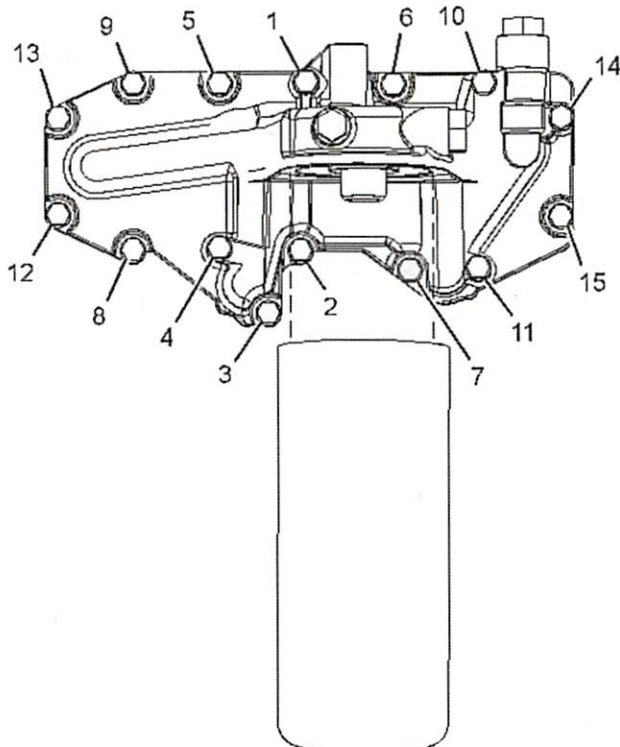

Illustration 2

g01258101

2. Install the gasket and engine oil filter base (5). Install bolts (4).



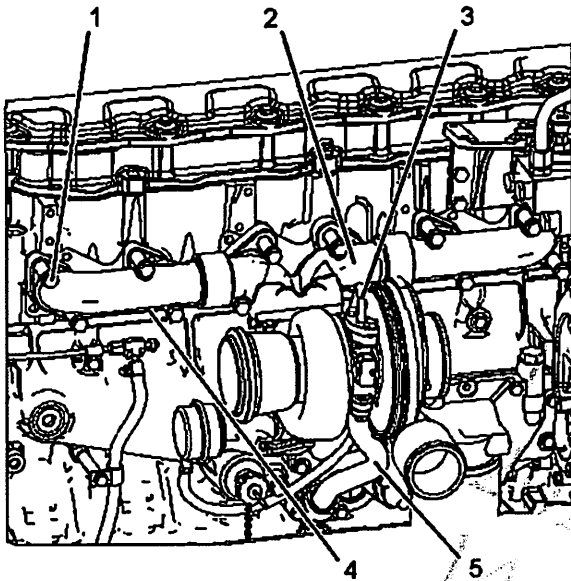

Illustration 2

g01124147

1. Apply Tooling (A) to the outside diameter of the male ends of exhaust manifold (2). Assemble exhaust manifold (2) and remove the excess sealer from the joints.
2. If the studs were removed from exhaust manifold (2), then replace with new studs. Tighten the studs to a torque of 35 ± 5 N·m (26 ± 4 lb ft).
3. If the turbo was removed, apply Tooling (B) to the threads of the studs and tighten the lock nuts to a torque of 54 ± 5 N·m (40 ± 4 lb ft).
4. Apply Tooling (B) to the threads of new bolts or studs (1). Attach a suitable lifting device to exhaust manifold (2) and the turbocharger. The weight of exhaust manifold (2) and the turbocharger is approximately 40 kg (88 lb). Position the gaskets, exhaust manifold (2), and the turbocharger on the cylinder head assembly. Install locks (4) and new bolts or studs (1).
 Note: If studs are used, install the studs and tighten the studs to a torque of 55 ± 10 N·m (41 ± 7 lb ft).
5. Connect tube assembly (3) and tube assembly (5).

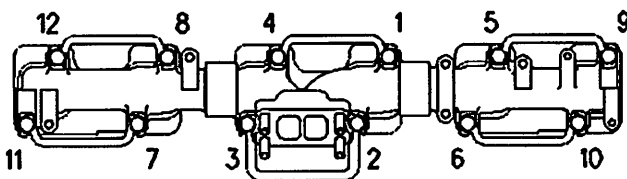

Illustration 3

g00617739

6. Tighten Bolt or Nut (1) through Bolt or Nut (12) in a numerical sequence.
 Tighten bolts or nuts to the following torque. ... 4 ± 1 N·m (35 ± 9 lb in)
7. Tighten Bolt or Nut (1) through Bolt or Nut (12) in a numerical sequence.
 Tighten bolts or nuts to the following torque. ... 55 ± 5 N·m (41 ± 4 lb ft)
8. Bend the locking tab over the flat of each bolt head.
 Note: Prior to starting or running the engine, allow the sealant in the exhaust manifold joints to air dry for 24 hours.

C7T1-UP, FML1-UP, FMM1-UP, KAL1-UP, LBM1-UP, NPH1-UP, SAP1-UP, WAX1-UP, YPG1-UP

SMCS - 1059

i08260909

Removal Procedure

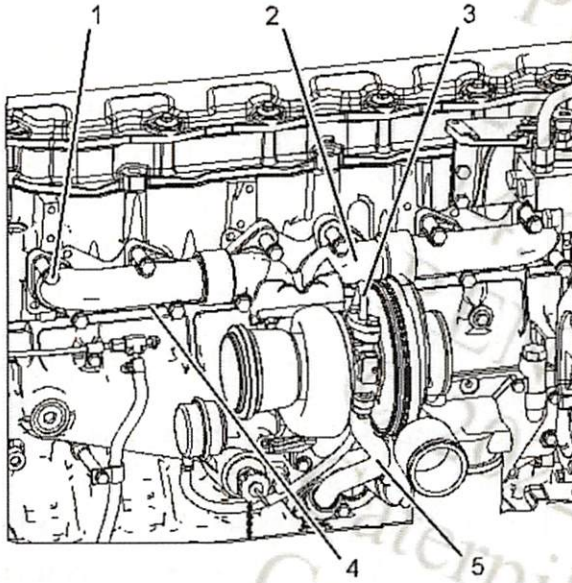

Illustration 1

g01124147

1. Disconnect tube assembly (3) and tube assembly (5).
2. Attach a suitable lifting device to exhaust manifold (2) and the turbocharger. The weight of exhaust manifold (2) and the turbocharger is approximately 40 kg (88 lb).
3. Remove bolts (1) and locks (4). Discard bolts (1).
4. Remove exhaust manifold (2), the turbocharger, and the gaskets from the cylinder head assembly.

Installation Procedure

Required Tools			
Tool	Part Number	Part Description	Qty
A	2P-2333	High Temperature Sealer	1
B	-	Loctite C5A ⁽¹⁾	-
	-	Loctite 8008	-

Table 1

⁽¹⁾ For use in North America only.

NOTICE

Excessive use of sealant can cause damage to components.

To avoid component damage use only the amount of sealant necessary for the application.

WRENCHHEAD MECHANICAL

3135 4 ST
NISKU, ALBERTA. T9E-8L1
Phone: 780-436-9570 Fax: 780- *KA*

INVOICE

40745

INVOICE

Printed Date: 03/29/2023 **Work Completed: 03/29/2023**

CHEMCO ELECTRICAL-HEAVY DUTY

3135-4th ST
NISKU, AB T9E-8L1
Office 780-436-9570 -- Home 780-436-9570

2006 Peterbilt - 335 UNIT#U125-1 - CATERPILLAR C-7 ADEM /
Lic # : Odometer In : 0
Unit # : PT-0198
VIN # : 2NPLLD9X2 6M660198

Part Description / Number	Qty	Sale	Ext	Labor Description	Ext
Shop Supplies			28.75	(1)REPAIRS AS REQUIRED AT PLATINUM * CERT BOOM	n/c
				BOOM CERTIFICATION KOVA INV #E58918	575.00

Org. Estimate 0.00 Revisions 0.00 Current Estimate 0.00

Labor:	0.00
Parts:	28.75
Sublet:	575.00
SubTotal:	603.75
Tax:	30.19
Total:	633.94
Bal Due:	\$633.94

[Payments -] *STK-29*

Vehicle Received: 3/9/2023

Customer Number : 1561

GST#865376503RT0001

Signature _____ Date _____

WRENCHHEAD MECHANICAL

3135 4 ST
 NISKU, ALBERTA. T9E-8L1
 Phone: 780-436-9570 Fax: 780- -



INVOICE

41812

Org. Est. # 058586

INVOICE

Printed Date: 07/05/2023 Work Completed: 07/05/2023

CHEMCO ELECTRICAL-HEAVY DUTY

3135-4th ST
 NISKU, AB T9E-8L1
 Office 780-436-9570 -- Home 780-436-9570

2006 Peterbilt - 335 UNIT#U125-1 - CATERPILLAR C-7 ADEM /
 Lic # : Odometer In : 211309
 Unit # : PT-0198
 VIN # : 2NPLLD9X2 **6M660198**
 Engine Hrs In : 809.0 Engine Hours Out : 809.0

Part Description / Number	Qty	Sale	Ext	Labor Description	Ext
O RING SEAL-ORDER 8H2046	1.00	10.97	10.97	(1) REPAIRS AS REQUIRED AT PLATINUM ** SEE TECH SHEET	2,990.00
POWER STEERING FILTER-STK 87904MP	1.00	31.09	31.09		
ATF DEX3 TRANS OIL/1L-STK ATFP	3.00	7.05	21.15		
#10 CLOTH COVERED HOSE /FT-ORDER 1503-10	10.00	9.30	93.00		
#10 SAE FEMALE HOSE FITTING -ORDER 4401-10	2.00	21.84	43.68		
MASTER DISCONNECT SWITCH -ORDER 2484-16	1.00	107.64	107.64		
CLUTCH PEDAL PAD-ORDER 06-00007	1.00	50.66	50.66		
WIPER NOZZLES-ORDER 106-811	2.00	14.91	29.82		
8-1/2" POSITVE BATTERY CABLE-STK 84-9305EAP	1.00	23.01	23.01		
TALL BATTERY NUT-STK 76-2621PKP	1.00	4.66	4.66		
4/0 BATTERY CABLE PER/FT-STK BAT-4/0-BKP	3.00	11.68	35.04		
TOGGLE SWITCH-STK 16-04830P	1.00	71.37	71.37		
R134A A/C GAS/LB-STK R134AP	3.00	10.10	30.30		
1 GA BLK BATTERY CABLE-STK BAT-1BKP	3.00	4.50	13.50		
BATTERY 31S 1000CCA 1250CA 190RC-STK 31S-1000P	3.00	104.91	314.73		
Shop Supplies			100.00		

WRENCHHEAD MECHANICAL

3135 4 ST
NISKU, ALBERTA. T9E-8L1
Phone: 780-436-9570 Fax: 780- -

INVOICE

41812

Org. Est. # 058586

INVOICE

Printed Date: 07/05/2023 Work Completed: 07/05/2023

CHEMCO ELECTRICAL-HEAVY DUTY

3135-4th ST
NISKU, AB T9E-8L1
Office 780-436-9570 -- Home 780-436-9570

2006 Peterbilt - 335 UNIT#U125-1 - CATERPILLAR C-7 ADEM /
Lic # : Odometer In : 211309
Unit # : PT-0198
VIN # : 2NPLLD9X2 **6M660198**
Engine Hrs In : 809.0 Engine Hours Out : 809.0

Part Description / Number	Qty	Sale	Ext	Labor Description	Ext
---------------------------	-----	------	-----	-------------------	-----

Org. Estimate 0.00 Revisions 0.00 Current Estimate 0.00

Labor:	2,990.00
Parts:	980.62
SubTotal:	3,970.62
Tax:	198.53
Total:	4,169.15
Bal Due:	\$4,169.15

[Payments -]

stk-645

Vehicle Received: 6/20/2023

Customer Number : 1561

GST#865376503RT0001

Signature _____ Date _____

WRENCHHEAD MECHANICAL

3135 4 ST
NISKU, ALBERTA. T9E-8L1
Phone: 780-436-9570 Fax: 780- -



REPAIR ORDER #

041812

Org. Est. # 058586

REPAIR ORDER - RO

Scheduled : 06/20/2023 06:57 AM

Print Date : 6/20/2023

CHEMCO ELECTRICAL-HEAVY DUTY

3135-4th ST
NISKU, AB T9E-8L1
Office 780-436-9570 --- Home 780-436-9570
Cust ID : 1561
Last Service : 3/29/2023

2006 Peterbilt - 335 UNIT#U125-1 - CATERPILLAR C-7 ADI

Lic # : - ALBERTA
Unit # : PT-0198
VIN # : 2NPLLD9X2 6M660198
MFG Date : 5/3/2017
Current Odom : 0

Previous Odom : 210780

Elapsed : 0

Labor Requested / Part SubTotal **Extended**

(1)REPAIRS AS REQUIRED AT PLATINUM

*List of repairs & repairs found while working on truck
are completed*

Parts Subtotal 0.00

Parts: 0.00
Labor: 0.00

Total: 0.00
Balance: 0.00

TEARDOWN ESTIMATE: I understand that my vehicle will be reassembled within ___ days of the date shown above if I choose not to authorize the service recommended. All Parts removed will be discarded unless instructed otherwise: Save all Parts ____. NOT RESPONSIBLE FOR LOSS OR DAMAGE TO MY VEHICLE OR ARTICLES LEFT IN VEHICLES IN CASE OF FIRE, THEFT OR ANY OTHER CAUSE. ALL VEHICLES LEFT MUST HAVE OWN INSURANCE. ANY VEHICLES LEFT OVER 30 DAYS WITHOUT CONSENT WILL BE PROPERTY OF WRENCHHEAD MECHANICAL.

Authorized By _____ Date _____ Time _____

Unit #: PT-0198 S/N:

Odometer: 211309

Hours: 809

Lab#	Repair Description	Date	Location	Tech Name	Hours
	Truck hard starting - Check injection activation pressure with Computer. Found Codes for low fuel pressure - low side pressure problems. Replaced fuel primer pump that was ordered in. Go through parts ordered in. Remove ignition switch & remove switch cylinder - install in new switch. Mark, add lines & hoses in dash panel & remove front cluster panel. Remove & replace Volt meter. Wipe out oil accumulated behind panel. Lose out starting ability.	June 20/23	P.shop	J. Davis	9.5
	Assemble front dash panel - Install ignition switch in panel - test operation. Truck hard starting issues seem to be much better - Truck tires up quickly	June 21/23	P.shop	(Signature)	2
	Assembled Dash upper & cluster panel into place. Replaced any dash lights for fuse burnt out. Assemble lower kick panels, fender. Run & check starting and cruise operations	June 22/23	P.shop	(Signature)	2
					12.5

Parts

Mechanic ID:

Mechanic Signature:

Qty.	Part #	Description	STK/ORD	Qty.	Part #	Description	STK/ORD
✓ 1	M-1375541	Fuel Primer Pump	ord	1		oil return line (turbo)	o.d
✓ 1	222-2880	belt tensioner	ord	1		oil pressure hose (turbo)	ord
✓ 1	89101	belt tensioner Pulley	ord	1		flange O-ring	ord
✓ 1	P27-6076	Switch (ignition)	ord	1		Tube O-ring	ord
✓ 1	17-04315-180	Volt meter	ord	1		Breather mount O-ring	ord
✓ 1	1904131-5	Relay	ord	3		ATF	stk.
✓ 1	164-0210	Breather	ord			Dash screws	stk.
✓ 1	Q79699	Power steering Res. Basket	ord			Dash clips	ord
✓ 1	87904MP	Power steering filter	stk.				stk.

on prev inv 41003

WRENCHHEAD MECHANICAL

3135 4 ST
NISKU, ALBERTA. T9E-8L1
Phone: 780-436-9570 Fax: 780- -

REPAIR ORDER #

041003

REPAIR ORDER - RO

Scheduled : 03/29/2023 11:08 AM

Print Date : 6/9/2023

CHEMCO ELECTRICAL-HEAVY DUTY

3135-4th ST

NISKU, AB T9E-8L1

Office 780-436-9570 --- Home 780-436-9570

Cust ID :

Last Service : 3/29/2023

Previous Odom : 210780

2006 Peterbilt - 335 UNIT#U125-1 - CATERPILLAR C-7 ADI

Lic # : - ALBERTA

Unit # : PT-0198

VIN # : 2NPLLD9X2 6M660198

MFG Date : 5/3/2017

Current Odom : 0

Elapsed : 0

Labor Requested / Part SubTotal

Extended

(1) REPAIRS AS REQUIRED AT PLATINUM

Parts Subtotal 4,176.22

Parts: 4,176.22

Labor: 0.00

Tax: 208.81

Total: 4,385.03

Balance: 4,385.03

TEARDOWN ESTIMATE: I understand that my vehicle will be reassembled within ___ days of the date shown above if I choose not to authorize the service recommended. All Parts removed will be discarded unless instructed otherwise: Save all Parts ____. NOT RESPONSIBLE FOR LOSS OR DAMAGE TO MY VEHICLE OR ARTICLES LEFT IN VEHICLES IN CASE OF FIRE, THEFT OR ANY OTHER CAUSE. ALL VEHICLES LEFT MUST HAVE OWN INSURANCE. ANY VEHICLES LEFT OVER 30 DAYS WITHOUT CONSENT WILL BE PROPERTY OF WRENCHHEAD MECHANICAL.

Authorized By _____ Date _____ Time _____

Unit #: PT-0198

S/N:

Odometer: 211309

Hours: 809

Lab#	Repair Description	Date	Location	Tech Name	Hours
	Remove breather cover - order mount o-ring. Remove Turbo oil supply hose, remove ext return pipe. order return hose & clamp & plug. Replace both supply & return pipe & O-rings Access of circuit - remove Air plucking to gain better access - reassemble & run engine to check for oil leaks & noise. Remove & replace power steering filter & oil. Found Engine won't idle up - hook up computer - test, switches Found Cruise/PTO ON/OFF switch not responding. Switch defective: order new switch. Had to disassemble dash again to make hole where data plug protrudes - larger split panel over so computer plug goes in far enough to make a solid connection.	June 23/23	Pishop	D. Dunning	7.5
	Remove air dryer, swap over fittings & mount brackets & install new dryer. Remove Air Compressor - Air dryer supply line - found & replace - leaking air. - order parts. Install front RH steering - torque to spec. Remove batteries - No Good - Install disconnect switch in battery lead.	June 26/23	Pishop		9
					16.5

Parts

Mechanic ID:

Mechanic Signature:

Qty.	Part #	Description	STK/ORD	Qty.	Part #	Description	STK/ORD
✓ 1	76-2621 PKP	Battery nut	STK				
✓ 2	Shop Supplies	battery cable ends ^{110x38} 3/8 eyelets	STK				
✓ 2	Shop Supplies	410x38 cable ends	STK				
✓ 3'	BAT-4/0-BKP	4/0 Battery cable.	STK				
✓ 3'	BAT-1/0-BKP	1/0 Battery cable.	STK				
✓ 3LBS	R134A P	R134A refrigerant	STK.				
✓ 1	P 06-00007	clutch pedal pad	ord				
✓ 1	Toggle Switch	#16-09830	ord				

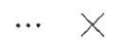

Platinum Alberta Maintenance

PT 125-1/PT-0198

Last changed moments ago by you



Repairs Approved

Bucket

In yard to do

Progress

Not started

Priority

Important

Start date

Start anytime

Due date

06/02/2023

Repeat

Does not repeat

Notes

Show on card

Speedo has not worked since early Jan. Can we please get this fixed when a space opens up in the shop

Checklist 9 / 14

Show on card

- Speedo don't work
- Not tracking the KM when driving
- Volt-meter not working
- Hard starting, fuel pressure bleeding back
- truck ABS light on/off
- Cowboy radio randomly loses power while driving
- Elog doesnt switch status
- Windshield washer doesn't spray, resevoir full
- Washer fluid tank lid is broken
- Red inspection out of date
- Binder needs updating
- Clutch linkage stiff

Print / Add to calendar



Priority

! Important



Start date

Start anytime



Due date

06/02/2023



Repeat

Does not repeat



Notes

Show on card

Speedo has not worked since early Jan. Can we please get this fixed when a space opens up in the shop speedo is repaired.

Checklist 9 / 14

Show on card

- Speedo don't work
- Not tracking the KM when driving
- Volt meter not working - *Replaced*
- Hard starting, fuel pressure bleeding back - *Hand primer or dump*
- truck ABS light on/off
- Cowboy radio randomly loses power while driving - ?
Checked power point connections - Good.
- Elog doesn't switch status
- Windshield washer doesn't spray, resevoir full
- Washer fluid tank lid is broken ↑ 🗑
- Red inspection out of date
- Binder needs updating
- Clutch linkage stiff - *Grease lubricate*
- Power steering noisy - *new filter + fresh oil*
- Hydraulic tank must be replaced Incident# 11918
- Add an item

Attachments

PT-0198 Chemco Mar.29.2
<https://chemco.sharepoint.com> ...

Show on card

Add attachment

Suggested attachments

PT-125 / PT-0198

Nisku X In Use X

Bucket

Light Duty Repairs Nee... v

Progress

○ Not started v

Priority

! Important v

Start date

Start anytime [calendar icon]

Due date

Due anytime [calendar icon]

Repeat

↻ Does not repeat v

Notes

Show on card

Speedo has not worked since early Jan. Can we please get this fixed when a space opens up in the shop

Checklist 0 / 13

Show on card

- Speedo don't work
- Not tracking the KM when driving
- Volt meter not working
- Hard starting, fuel pressure bleeding back
- truck ABS light on/off
- Cowboy radio randomly loses power while driving
- Elog doesnt switch status
- Windshield washer doesn't spray, resevoir full
- Washer fluid tank lid is broken
- Red inspection out of date
- Binder needs updating
- Clutch linkage stiff
- Power steering noisy *new filter on it*
- Add an item

Attachments

Add attachment

Suggested attachments

Comments

WRENCHHEAD MECHANICAL

3135 4 ST
NISKU, ALBERTA. T9E-8L1
Phone: 780-436-9570 Fax: 780- -

INVOICE

37990

INVOICE

Ref # : 655 HOURS

Printed Date: 06/20/2022

Work Completed: 06/20/2022

CHEMCO ELECTRICAL-HEAVY DUTY

3135-4th ST
NISKU, AB T9E-8L1
Office 780-436-9570 -- Cellular 780-231-0871

2006 Peterbilt - 335 UNIT#U125-1 - CATERPILLAR C-7 ADEM /
Lic # : Odometer In : 210779
Unit # : PT-0198
VIN # : 2NPLLD9X2 **6M660198**
Engine Hrs In : 655.0 Engine Hours Out : 655.0

Part Description / Number	Qty	Sale	Ext	Labor Description	Ext
LH LED LAMP -ORDER 53640EA	1.00	117.03	117.03	(1) REPAIRS AS REQUIRED AT PLATINUM * REPLACE LH REAR OUTRIGGER CYLINDER	1,430.00
#8JIC X #6ORB 90 ADAPTER -ORDER 2062-6-8	2.00	3.73	7.46	* REPLACE LEFT REAR TAIL LIGHT SEND OUTRIGGER CYLINDER AND PINS FOR RE-BUILD	2,184.12
HYD OIL-STK AW-32P	10.00	3.99	39.90	DYNAMIC FLUID INV#1008528	
BRAKE KLEEN-STK B/C	4.00	2.20	8.80		
Shop Supplies			100.00		

Org. Estimate 4,081.68 Revisions 0.00 Current Estimate 4,081.68

Labor:	1,430.00
Parts:	273.19
Sublet:	2,184.12
SubTotal:	3,887.31
Tax:	194.37
Total:	4,081.68
Bal Due:	\$4,081.68

[Payments -]

STK 149

Vehicle Received: 6/20/2022

Customer Number : 1561

GST#865376503RT0001

Signature _____ Date _____



PLATINUM SERVICE REQUEST

	IN		OUT		TECH: <i>STAN</i>
DATE(D/M/Y)					
UNIT #	<i>PT-0198</i>		CVIP DUE:		
SERVICE DUE @	ENGINE HRS	ODOMETER	BLOWER HRS	BOILER HRS	PUMP HRS
	<i>655</i>	<i>210779</i>			

11/22/2005 VIN# *2NPLD9X26M660198* model # *PB335*

	REPAIRS REQUEST	REPAIRS COMPLETED	HRS
1	<i>R&R L.H. REAR OUTRIGGER CYL.</i>		<i>8</i>
2			<i>6</i>
3	<i>REPLACE L. REAR TAIL LIGHT.</i>		<i>8</i>
4			
5			
6			
7			
8			
9			
10			

QTY		STK/SUP	QTY	STK/SUP
<i>1</i>	<i>CYL</i>	<i>SUBLET</i>		
<i>10L</i>	<i>AW32</i>	<i>STK</i>		
<i>4</i>	<i>B/C</i>	<i>STK</i>		
<i>2</i>	<i>FITTINGS</i>	<i>Greggord ord</i>		
<i>1</i>	<i>TAIL Light</i>	<i>ord</i>		

WRENCHHEAD MECHANICAL

3135 4 ST
NISKU, ALBERTA. T9E-8L1
Phone: 780-436-9570 Fax: 780-

INVOICE

36948

INVOICE

Date: 12/09/2021

CHEMCO ELECTRICAL-HEAVY DUTY

3135-4th ST
NISKU, AB T9E-8L1
Office 780-436-9570 -- Cellular 780-231-0871

2006 Peterbilt - 335 UNIT#U125-1 - CATERPILLAR C-7 ADEM /
Lic # :
Unit # : PT-0198
VIN # : 2NPLLD9X2 6M660198
Odometer In : 0

Part Description / Number	Qty	Sale	Ext	Labor Description	Ext
5" ZIP DISC-STK 11T052	1.00	4.66	4.66	(1) REPAIRS AS REQUIRED * REPAIRED AND WELDED SUB-FRAME AS PER CERT INSPECTION * KEVIN GRAMS WELDED	455.00
5" CUT OFF DISC-STK 08N503	1.00	5.15	5.15		
Shop Supplies			22.75		

Org. Estimate 0.00 Revisions 0.00 Current Estimate 0.00

Labor:	455.00
Parts:	32.56
SubTotal:	487.56
Tax:	24.38
Total:	511.94
Bal Due:	\$511.94

[Payments -]
Vehicle Received: 12/2/2021

STK-33

Customer Number : 1561

GST#865376503RT0001

Signature _____ Date _____

WRENCHHEAD MECHANICAL

3135 4 ST
NISKU, ALBERTA. T9E-8L1
Phone: 780-436-9570 Fax: 780- -

REPAIR ORDER #

036948

REPAIR ORDER - RO

Scheduled : 12/02/2021 08:09 AM

Print Date : 12/2/2021

CHEMCO ELECTRICAL-HEAVY DUTY

3135-4th ST
NISKU, AB T9E-8L1
Office 780-436-9570 --- Cellular 780-231-0871
Cust ID :
Last Service : 2/4/2021

2006 Peterbilt - 335 UNIT#U125-1 - CATERPILLAR C-7 ADI
Lic # : - ALBERTA
Unit # : PT-0198
VIN # : 2NPLLD9X2 **6M660198**
MFG Date : 5/3/2017
Previous Odom : 209360
Current Odom : 0
Elapsed : 0

<i>Labor Requested / Part SubTotal</i>	Extended
<i>(1) REPAIRS AS REQUIRED</i>	
	Parts Subtotal 0.00

Parts: 0.00
Labor: 0.00

Total: 0.00
Balance: 0.00

TEARDOWN ESTIMATE: I understand that my vehicle will be reassembled within ___ days of the date shown above if I choose not to authorize the service recommended. All Parts removed will be discarded unless instructed otherwise: Save all Parts ____. NOT RESPONSIBLE FOR LOSS OR DAMAGE TO MY VEHICLE OR ARTICLES LEFT IN VEHICLES IN CASE OF FIRE, THEFT OR ANY OTHER CAUSE. ALL VEHICLES LEFT MUST HAVE OWN INSURANCE. ANY VEHICLES LEFT OVER 30 DAYS WITHOUT CONSENT WILL BE PROPERTY OF WRENCHHEAD MECHANICAL.

Authorized By _____ Date _____ Time _____

Technician Work Sheet Service Writer : **ANDREW, RYAN**

Print Date: 12/02/2021

2006 Peterbilt - 335 UNIT#U125-1

Hat # :

VIN # : 2NPLLD9X2 6M660198

Color :

Engine : CATERPILLAR C-7 ADEM A4/ACERT EPAI

Location :

Repair Order #

036948

Lic # :

Lic. State : ALBERTA

CHEMCO ELECTRICAL-HEAVY DUTY

Office 780-436-9570 --- Cellular 780-231-0871

Schedule :

Promised Date : 12/02/21 5:00 P.M.

Inspection Date : 5/03/17

Status :

Last Service : 2/04/21

Unit # : PT-0198

Current Odometer : 0

Trans :

Previous Mileage : 209,360

Brakes :

Elapsed Mileage : 0

Manufacture Date : 5/03/17

Labor Description

Charged Hours

(1) REPAIRS AS REQUIRED

Technician: <none>

OUT ODOMETER :

Hours out: 0.00

Tech Notes
