

J22-12  
MAY

# INVOICE

## Ace Equipment

Phone 780-718-7175

Date: July 2 2025  
 Invoice #: 124537  
 P.O. 55

To: Cariboo Railroad  
 Contracting Corp  
 Kelowna B.C  
 V1X 6A1

Sales	Shipping	Shippin Delivery	Payment
Contact	Job	Method	Terms
		Terms	Due Date
Ed	124537	n/a	At Delivery

Qty	Item #	Description	Unit Price	Line Total
Model	Ford			
Serial #	1FD0W5HT4KEE14684			
Unit	55			

### Work Performed

- Perform hi rail inspection
- Replace rail sweeps and brackets as required
- Remove all wheels and replace and repack bearings as required
- Clean rear locking mechanism as it was seized
- Adjust locks as required for front hi rail
- Replace battery cable that was not attached for ground on front hi rail motor, cable was hanging down and not attached
- Give unit general check over
- Replace broken elbow on tank on side of unit
- Remove damaged grab handle at rear of unit as sharp pieces were sticking out
- Replace grab handle
- Replace damaged tool box latches as required as doors would not shut
- Function tail gate, unit would not function properly, found switch circuit board to be damaged and electric solenoid and valve on power pack to not operate
- Rewire switch to eliminate circuit board, replaced solenoid and valve as required
- Replace right rear I.D. light as plug was rotted off
- Replace missing retaining ring on box door as hinge is falling apart

### Invoicing Detail

Labour 24 @ \$159/hr	\$	3,816.00
Shop supplies 8% of labour	\$	305.28

Bushing	\$	9.39
Elbow	\$	3.63
Grab handle	\$	22.95
Light	\$	10.06
Valve and solenoid	\$	346.11
Tool box handle asseys	\$	233.98
Retainer ring	\$	0.38
Battery cable assy	\$	51.60
Bearings and seals	\$	383.04
Rail sweeps and brackets	\$	767.00

GST # 138876693RT001	Subtotal	\$	5,949.42
	5% Sales Tax		297.47
	Total	\$	<b>6,246.89</b>

**Make all cheques payable to Ace Equipment**

**Mailing Address: 36 Meadowbrook Road Sherwood Park Alta T8A 0N9**

**Job Code: BC.CN.UN55.HR**  
**Equipment Unit #: UN55**  
**Comment:**

*Tim Hawryluk*



# Cariboo Rail Hi-Rail Inspection

FLEET COORDINATOR 250-640-0553

Email tfroehlich@cariboorail.com

DATE: May 12 12E

VIN #: LEDDWSH74KEE14684

Job Number: 124537

Unit #: 55

Odometer: \_\_\_\_\_ Km MI

Vendor: Cariboo Rail

Front Hirail: Make: Rafina Model: \_\_\_\_\_ S/N: \_\_\_\_\_

Rear Hirail: Make: Rafina Model: \_\_\_\_\_ S/N: \_\_\_\_\_

450 S/N: \_\_\_\_\_  
450 S/N: \_\_\_\_\_

**WORK DESCRIPTION**

"P" Pass "F" Fail "R" Repair Future Attention "N" Not Applicable

#	Items to Inspect	P	F	R	A	N	Notes
1	Manufacturer Manual	✓					
2	Lights, Beacon	✓					
3	Back up alarm	✓					
4	Measure Tire Thread Depth	✓					
5	Tire Air Pressure	✓					
6	Front & Rear Bellows	✓					
7	Rubber Jounce	✓					
8	Steering Lock	✓					
9	Steering Stoppers	✓					
10	Suspension Locks / Rods	✓					
11	Lock Pins	✓					
12	Electrical box / Wiring	✓					
13	Guide Wheels for Wear	✓					
14	Guide Wheel Bearings / Seals	✓					
15	Spindles	✓					
16	Guide Tube & Pivot	✓					
17	Lube Complete Hirail	✓					
18	Rail Sweeps (1/8 Gap)	✓					
19	Hi rail Brakes	✓					
20	Hi Rail Pressure	✓					
21	String Line (if required)	✓					
22	Hirail Weight, (Record next page)					✓	
23	Hirail Height, (Record next page)					✓	
24	Torque wheel Nuts <u>165</u> lbs	✓					
25	Air System Operation					✓	
26	Air System Components					✓	
27	Hydraulic System Operation	✓					
28	Hydraulic Components	✓					
29	Creep Drive Operation					✓	
30	Track Test					✓	

P F R A N

Inspected By: Edward Poitard

Signature: [Signature]

# INVOICE

## Ace Equipment

Phone 780-718-7175

Date: Feb 28 2025  
 Invoice #: 124501  
 P.O. 55

To: Cariboo Railroad  
 Contracting Corp  
 Kelowna B.C  
 V1X 6A1

Sales		Shipping	Shippin Delivery		Payment	
Contact	Job	Method	Terms	Date	Terms	Due Date
Ed	124501		n/a			At Delivery

Qty	Item #	Description	Unit Price	Line Total
Model	Ford			
Serial #	1FD0W5HT4KEE14684			
Unit	55			

**Work Performed**

Diagnosis check engine light on  
 Found code for def heater  
 Check def heater assy, found plug to be badly corroded on heater  
 Replaced heater and line as it is one assy  
 Clear codes

**Invoicing Detail**

Labour 4hrs @ \$159/hr	\$	636.00
Shop supplies 8% of labour	\$	50.88
Tube assy	\$	303.55

GST # 138876693RT001

Job Code: ab.ip.gp.hr  
 Equipment Unit #: Unit 55  
 Comment:

*Tim Hawryluk*

Subtotal	\$	990.43
5% Sales Tax		49.52
<b>Total</b>	<b>\$</b>	<b>1,039.95</b>

**Make all cheques payable to Ace Equipment**

CUSTOMER #:  
UNIT# 55

231601

Terry Ortynsky's  
**ROYAL**  
FORD

Phone (306) 782-2261  
Parts (306) 783-8559  
Fax (306) 786-6515  
Email customerservice@royalford.ca  
www.terryortynsky.com  
81 Dracup Avenue  
Yorkton, SK S3N 3P9  
GST# 104644364

\*INVOICE\*

DUPLICATE 1  
PAGE 1

*We Make It Easy!*

CARIBOU RAIL  
209-307 BANKS RD  
KELOWNA, BC V1X 6A1  
HOME: 778-478-1746 CONT: 778-478-1746  
BUS: CELL: SERVICE ADVISOR: 129 BRIAN MAYER

COLOUR	YEAR	MAKE/MODEL	VIN	LICENSE	ODOMETER IN/ OUT	TAG	
WHITE	19	FORD F550	1FD0W5HT4KEE14684	739LLO	222732/222732	T684	
DEL DATE	PROD. DATE	WARR. EXP.	PROMISED	PO NO.	RATE	PAYMENT	INV. DATE
01JAN19 DD			17:00 06DEC24		150.00	INS	28NOV24
R.O. OPENED	READY	OPTIONS:					
09:23 06SEP24	09:20 28NOV24	DLR:B4016 1)DRIVING FORCE UNIT -		157912			

LINE	OPCODE	TECH	TYPE	HOURS	LIST	NET	TOTAL
------	--------	------	------	-------	------	-----	-------

A Body Shop Repairs  
89 B/S Misc.

157	CB	45.80			5791.42	5791.42	
BSM Body Shop Materials							
1	LC3Z*16612*C	HOOD ASY		1440.08	1370.17	1370.17	
1	HC3Z*2650202*B	PANEL ASY - ROOF		1257.23	1236.47	1236.47	
1	HC3Z*26537A49*B	BRACKET		81.72	81.72	81.72	
1	FL3Z*1650222*A	REINFORCEMENT		62.05	62.05	62.05	
1	HC3Z*2651729*AC	MOULDING - ROOF SIDE		241.32	241.32	241.32	
1	HC3Z*17683*BA	MIRROR ASY - REAR VI		1635.05	1635.05	1635.05	
1	FL3Z*1624631*D	DOOR ASY - REAR - LE		1752.15	1752.15	1752.15	
1	FL3Z*1625713*G	GLASS - REAR DOOR		437.43	437.43	437.43	
1	HC3Z*2542006*B	GLASS - FIXED		650.22	650.22	650.22	
1	DW02354GTY	CAR W/SHIELD		536.95	536.95	536.95	
1	HC3Z*26211A11*B	FRAME - DOOR		1353.83	1353.83	1353.83	
2	*W717984*S417	RIVET - BLIND		4.46	4.46	8.92	
1	HC3Z*17D743*AA	COVER		61.63	61.63	61.63	
SUBL AUTO TRIM DESIGN - INSTALL DECALS ON BOTH DOORS							
CB							
					320.00	320.00	
PARTS:	9427.91	LABOR:	5791.42	OTHER:	1330.93	TOTAL LINE A:	16550.26

B Body Shop Refinish  
89 B/S Misc.

223	CBP	20.80			2630.16	2630.16	
BSPM Body Shop PAINT Materials							
					1636.75	1636.75	
PARTS:	0.00	LABOR:	2630.16	OTHER:	1636.75	TOTAL LINE B:	4266.91

C Service Repairs  
98 MISC

127	CMS	14.16			2124.00	2124.00	
1	RTS*1069*	SEAL		17.93	17.93	17.93	
2	RTS*1070*	SEAL		17.93	17.93	35.86	
7	WT*56815*	KIT - TERMINAL		30.44	30.44	213.08	
2	*388898*S	SEAL		3.77	3.77	7.54	

TERMS: STRICTLY CASH UNLESS ARRANGEMENTS MADE	ALL ITEMS SUBJECT TO G.S.T.	DESCRIPTION	TOTALS
I HEREBY AUTHORIZE THE REPAIR WORK SET FORTH TO BE DONE ALONG WITH THE NECESSARY MATERIAL AND AGREE TO THE EXTENT PERMITTED BY LAW. YOU ARE NOT RESPONSIBLE FOR LOSS OR DAMAGE TO VEHICLE OR ARTICLES LEFT IN VEHICLE IN THE CASE OF FIRE, THEFT OR ANY OTHER CAUSE BEYOND YOUR CONTROL OR FOR ANY DELAYS CAUSED BY UNAVAILABILITY OF PARTS OR DELAYS IN PARTS SHIPMENTS BY THE SUPPLIER OR TRANSPORTER. I HEREBY GRANT YOU AND OR YOUR EMPLOYEES, PERMISSION TO OPERATE THE VEHICLE HEREIN DESCRIBED ON STREETS, HIGHWAYS OR ELSEWHERE FOR THE PURPOSE OF TESTING AND/OR INSPECTION. UNTIL PAYMENT IN FULL OF THE WITHIN ACCOUNT, I HEREBY ACKNOWLEDGE THE EXISTENCE OF A MECHANIC'S LIEN IN FAVOUR OF THE WITHIN DEALER ON THE VEHICLE DESCRIBED HEREIN IN RESPECT OF THE MATERIAL SUPPLIED AND SERVICES RENDERED UNDER THIS WORK ORDER FOR THE FULL AMOUNT CHARGED THEREFORE. I FURTHER ACKNOWLEDGE THAT THE SAID LIEN SHALL CONTINUE IN FORCE AT ALL TIMES, WHETHER THE VEHICLE IS IN MY POSSESSION IT SHALL BE SUBJECT TO REPOSSESSION ON DEMAND BY THE DEALER UNTIL THE WITHIN ACCOUNT IS PAID IN FULL.		LABOUR AMOUNT	
		PARTS AMOUNT	
		GAS, OIL, LUBE	
		SUBLET AMOUNT	
		MISC. CHARGES	
		TOTAL CHARGES	
		LESS INSURANCE	
		SALES TAX	
		PLEASE PAY THIS AMOUNT	

INDEBTEDNESS IS HEREBY ACKNOWLEDGED IN THE SUM OF \$ \_\_\_\_\_ BEING ALL OR THE BALANCE OWING FOR REPAIRS, PARTS AND ACCESSORIES DESCRIBED IN THIS WORK ORDER. ALL WARRANTY SUBJECT TO FACTORY ACCEPTANCE. DATE \_\_\_\_\_ SIGNATURE \_\_\_\_\_

CUSTOMER COPY

CUSTOMER #:  
UNIT# 55

231601

Terry Ortynsky's  
**ROYAL**  
FORD

Phone (306) 782-2261  
Parts (306) 783-8559  
Fax (306) 786-6515  
Email customerservice@royalford.ca  
www.terryortynsky.com  
81 Dracup Avenue  
Yorkton, SK S3N 3P9  
GST# 104644364

\*INVOICE\*  
DUPLICATE 1  
PAGE 2

*We Make It Easy!*

CARIBOU RAIL  
209-307 BANKS RD  
KELOWNA, BC V1X 6A1  
HOME: 778-478-1746 CONT: 778-478-1746

BUS: CELL: SERVICE ADVISOR: 129 BRIAN MAYER

COLOUR	YEAR	MAKE/MODEL	VIN	LICENSE	ODOMETER IN/ OUT	TAG	
WHITE	19	FORD F550	1FD0W5HT4KEE14684	739LLO	222732/222732	T684	
DEL DATE	PROD. DATE	WARR. EXP.	PROMISED	PO NO.	RATE	PAYMENT	INV. DATE
01JAN19 DD			17:00 06DEC24		150.00	INS	28NOV24
R.O. OPENED		READY	OPTIONS: DLR:B4016 1)DRIVING FORCE UNIT - 157912				
09:23 06SEP24	09:20 28NOV24						

LINE	OPCODE	TECH	TYPE	HOURS	LIST	NET	TOTAL
3	CVC*13*	G	ANTI-FREEZE		30.02	30.02	90.06
3	AFENV		Enviromental Fee		2.24	2.24	6.72

SUBL BAILLIE BOYS TOWING  
CMS 300.00 300.00  
PARTS: 364.47 LABOR: 2124.00 OTHER: 306.72 TOTAL LINE C: 2795.19

222732 Removed the cab, wrapped in bags and taped up all the electrical connectors and air inlets to protect them and pushed the frame outside. Installed the cab, repaired all the wires that I cut for removal. Filled and bled the cooling system.

\*\*\*\*\*

SHOP SUPPLIES

75.00

GST (#: R104644364)

1184.37  
1421.24

TERMS: STRICTLY CASH UNLESS ARRANGEMENTS MADE	ALL ITEMS SUBJECT TO G.S.T.	DESCRIPTION	TOTALS
<small>I HEREBY AUTHORIZE THE REPAIR WORK SET FORTH TO BE DONE ALONG WITH THE NECESSARY MATERIAL AND AGREE TO THE EXTENT PERMITTED BY LAW. YOU ARE NOT RESPONSIBLE FOR LOSS OR DAMAGE TO VEHICLE OR ARTICLES LEFT IN VEHICLE IN THE CASE OF FIRE, THEFT OR ANY OTHER CAUSE BEYOND YOUR CONTROL OR FOR ANY DELAYS CAUSED BY UNAVAILABILITY OF PARTS OR DELAYS IN PARTS SHIPMENTS BY THE SUPPLIER OR TRANSPORTER. I HEREBY GRANT YOU AND OR YOUR EMPLOYEES, PERMISSION TO OPERATE THE VEHICLE HEREIN DESCRIBED ON STREETS, HIGHWAYS OR ELSEWHERE FOR THE PURPOSE OF TESTING AND/OR INSPECTION, UNTIL PAYMENT IN FULL OF THE WITHIN ACCOUNT. I HEREBY ACKNOWLEDGE THE EXISTENCE OF A MECHANIC'S LIEN IN FAVOUR OF THE WITHIN DEALER ON THE VEHICLE DESCRIBED HEREIN IN RESPECT OF THE MATERIAL SUPPLIED AND SERVICES RENDERED UNDER THIS WORK ORDER FOR THE FULL AMOUNT CHARGED THEREFORE I FURTHER ACKNOWLEDGE THAT THE SAID LIEN SHALL CONTINUE IN FORCE AT ALL TIMES, WHETHER THE VEHICLE IS IN MY POSSESSION IT SHALL BE SUBJECT TO REPOSSESSION ON DEMAND BY THE DEALER UNTIL THE WITHIN ACCOUNT IS PAID IN FULL.</small>  <small>PRIVACY Personal information is collected in accordance with applicable privacy legislation and is governed by Terry Ortynsky Ford Privacy Policy. Ask us if you would like information about our Privacy Policy, including our service providers and their data processing in the U.S., which may be accessible to U.S. law enforcement and national security authorities. We provide this personal and transaction information to Ford Motor Company of Canada, Limited to enable Ford to administer your transaction, provide you with requested services, improve automotive related products and services by conducting customer surveys, and provide you with marketing material which may be of interest to you, as permitted by applicable laws. For the Ford Privacy Policy (www.ford.ca) including use of service providers and U.S. data storage or if you do not want to receive marketing or survey materials from Ford please call 1-800-565-FORD (3873).</small>		LABOUR AMOUNT	10545.58
		PARTS AMOUNT	9792.38
		GAS, OIL, LUBE	0.00
		SUBLET AMOUNT	620.00
		MISC. CHARGES	2729.40
		TOTAL CHARGES	23687.36
		LESS INSURANCE	20108.60
		SALES TAX	2605.61
		PLEASE PAY THIS AMOUNT	6184.37

INDEBTEDNESS IS HEREBY ACKNOWLEDGED IN THE SUM OF \$ \_\_\_\_\_ BEING ALL OR THE BALANCE OWING FOR REPAIRS, PARTS AND ACCESSORIES DESCRIBED IN THIS WORK ORDER. ALL WARRANTY SUBJECT TO FACTORY ACCEPTANCE. DATE \_\_\_\_\_ SIGNATURE \_\_\_\_\_

CUSTOMER COPY



**T&B Fleet Services**  
#2 877 Redonda St.  
Sunnyside, MB. R5R 0J4  
Phone: 204-222-3608  
Fleet Hiral Repairs & Vehicle Service

INVOICE

3478

Org. Est. # 002969  
GST #77259 9601 RT0001

## INVOICE

Printed Date: 06/12/2024

Work Completed: 06/12/2024

## CARIBOO RAILROAD CONTRACTING COR

117-3030 Pandosy Street  
Kelowna, BC V1Y 0C4  
Work 250-640-0553

2019 Ford - F-550 Super Duty XLT - 6.7L, V8 (406CI) VIN(T)

Lic # :

Odometer In : 214049

Unit # : 55

VIN # : 1FD0W5HT4 KEE14684

Part Description	Number	Qty	Sale	Ext	Labor Description	Hours	Ext
Battery Cable (black), 2 GA 82-5710		10.00	6.20	62.00	diagnose hirail pump just clicks found no ground to pump	2.00	270.00
PVC Jacketed Wire, 2 Cond, 14" 82-5502		0.20	114.06	22.81	recommend adding ground to pump ran ground wire from hirail pump and brake pump to battery		
Shop Supplies				13.93	diagnose beacon stopped working found beacon grounded to itself recommend adding proper ground cable ran ground cable from beacon to battery	1.50	202.50
					Enviro Fees		4.50
					Taxes		
					GST		28.79
					PST		40.30

Job Code: MB . CN . UN55 . HR

Task Code: A16NB

Equipment Unit #: 55

Comment: REPAIR

DocuSigned by:

*Tammy Froelich*  
C2DEEF0C9EDD4F2...

2024-06-17

Rec Jun 12/24

Org. Estimate 309.96 Revisions 0.00 Current Estimate 309.96

Labor:	472.50
Parts:	98.74
HazMat:	4.50
SubTotal:	575.74
Tax:	69.09
Total:	644.83
Bal Due:	\$644.83

[ Payments - ]

THANKS FOR YOUR BUSINESS!

Vehicle Received: 6/11/2024

Customer Number : 65

Wheel Nuts are torqued to factory specifications & must be rechecked within 100 KMS from time wheels were removed. T&B Fleet Services is not responsible for loss or damage to vehicles or articles left in vehicle in case of fire, theft, or any other cause beyond our control.

Parts Warranty is set by the manufacturer, typically 1 year. Labor Warranty is 90 days and must be performed in our shop and cannot exceed the original cost of repairs.

PAYMENT TERMS: Due Upon Receipt (Net 30 with a charge account). NOTE: If paying by credit card over the phone there will be a 2% charge to total invoice. We do not accept credit card payments over \$5000.

Signature \_\_\_\_\_ Date \_\_\_\_\_

Visit us on the web: www.tbfleetservices.ca

Email Address: info@tbfleetservices.ca

Service Advisor : Bowley, Butch, Tech : Bowley, Butch 160924; Winter, Jeremy 1122

Page 1 of 1

Copyright (c) 2024 Mitchell Repair Information Company, LLC Invhrs 5.12.21kr



**T&B Fleet Services**  
#2 877 Redonda St.  
Sunnyside, MB. R5R 0J4  
Phone: 204-222-3608  
Fleet Hirail Repairs & Vehicle Service

**INVOICE**

**3228**

Org. Est. # 002709  
GST #77259 9601 RT0001

**INVOICE**

Printed Date: 04/30/2024

Work Completed: 04/30/2024

**CARIBOO RAILROAD CONTRACTING COR**  
117-3030 Pandosy Street  
Kelowna, BC V1Y 0C4  
Work 250-640-0553

2019 Ford - F-550 Super Duty XLT - 6.7L, V8 (406CI) VIN(T)  
Lic # : Odometer In : 208784  
Unit # : 55  
VIN # : 1FD0W5HT4 KEE14684

Part Description	Number	Qty	Sale	Ext	Labor Description	Hours	Ext
Mobile 1 Epic Red Grease Tubes Size: 390MM 124557		4.00	10.82	43.28	Perform Hirail Inspection, repack wheels check bearings, string line unit and check contact patch	6.00	810.00
Brake & Parts Cleaner 890.9107DSC		2.00	5.48	10.96	check work lights and beacon REPLACE WORK BEACON	1.00 0.50	135.00 67.50
Shop Towels shop		2.00	6.00	12.00	REPLACE RF FRONT SWEEP and adjust all sweeps to proper heights	0.30	40.50
290 wheel seal 471271		4.00	16.56	66.24	REPLACE FRONT HI RAIL AXLE and inner tube assemblies	2.50	337.50
290 Wheel Bearing Race LM104911		3.00	20.46	61.38	REPLACE FRONT HI RAIL timbren springs	1.50	202.50
290 Wheel Bearing LM104949		3.00	35.08	105.24	REPLACE REAR UPPER AND LOWER WORK LAMPS & REPAIR WIRING	2.50	337.50
LED Beacon Amber 78853		1.00	196.93	196.93	REPLACE LEFT REAR MARKER LAMP & PIGTAIL WIRING	0.50	67.50
290 Sweep Rubbers R-20246		1.00	70.77	70.77	REPLACE BACK UP ALARM freight charges extra eta on parts 3 weeks, prices valid until march 31,2024	0.50	67.50 180.88
Hirail Axle R-4530		1.00	1,810.81	1,810.81	add 1 leaf spring to each leaf pack and level		1,355.39
Front Axle Inner Hirail Tube R-554		2.00	531.96	1,063.92	align hirail gear and set weights after repairs completed	2.00	270.00
Hirail Axle Rubber Springs R-556		2.00	192.54	385.08	aligned unit, set front toe, adjust weights to 1400lbs on rear as low as i could get them B.B.		
Square LED 27W LEDWT-10427WT		4.00	88.89	355.56	Enviro Fees		4.50
PIGTAIL RING TERMIN GRND W/BLN 67050		1.00	3.30	3.30			
CLR/MKR LAMP, 2, RED, HI COUNT G3002		1.00	17.53	17.53			
Back-Up Alarm, Econ Model 97DB 73040		1.00	43.20	43.20			
Shop Supplies				49.95			
<b>Taxes</b>							
GST							408.62
PST							572.07



www.tbfleetservices.ca

**T&B Fleet Services**  
 #2 877 Redonda St.  
 Sunnyside, MB. R5R 0J4  
 Phone: 204-222-3608  
 Fleet Hiral Repairs & Vehicle Service

**INVOICE**

**3228**

Org. Est. # 002709  
 GST #77259 9601 RT0001

**INVOICE**

Printed Date: 04/30/2024

Work Completed: 04/30/2024

**CARIBOO RAILROAD CONTRACTING COR**  
 117-3030 Pandosy Street  
 Kelowna, BC V1Y 0C4  
 Work 250-640-0553

2019 Ford - F-550 Super Duty XLT - 6.7L, V8 (406CI) VIN(T)  
 Lic # : Odometer In : 208784  
 Unit # : 55  
 VIN # : 1FD0W5HT4 KEE14684

Part Description	Number	Qty	Sale	Ext	Labor Description	Hours	Ext
------------------	--------	-----	------	-----	-------------------	-------	-----

**Job Code:** MB . CN . UN55 . HR

**Task Code:** A16NB

**Equipment Unit #:** 55

**Comment:** HI-RAIL INSPECTION

DocuSigned by:

*Tammy Froehlich*  
 C2DEEF0C9EDD4F2...  
 2024-05-07

DocuSigned by:

*[Signature]*  
 43532197E88E466...  
 2024-05-22

**Rec Apr 30/24**

Org. Estimate 1,337.01 Revisions 7,519.13 Current Estimate 8,856.14

Revision # 1, Previous Estimate Amount: 1337.01, Additional Cost: 7462.75, Revised Estimate: 8799.76, Parts: \$3862.83 Labor: \$1390.50 Sublet: \$1355.39 Taxes & Fees: \$854.03 Authorized by - . Date - 3/27/2024. Time - 11:40 AM. Initiated By - Shoo

Revision # 2, Previous Estimate Amount: 8799.76, Additional Cost: 56.38, Revised Estimate: 8856.14, Parts: \$-83.38 Labor: \$135.00 Sublet: \$0.00 Taxes & Fees: \$4.76 Authorized by - . Date - 3/27/2024. Time - 11:40 AM. Initiated By - Shoo

<b>Labor:</b>	<b>2,335.50</b>
<b>Parts:</b>	<b>4,296.15</b>
<b>Sublet:</b>	<b>1,536.27</b>
<b>HazMat:</b>	<b>4.50</b>
<b>SubTotal:</b>	<b>8,172.42</b>
<b>Tax:</b>	<b>980.69</b>
<b>Total:</b>	<b>9,153.11</b>
<b>Bal Due:</b>	<b>\$9,153.11</b>

[ Payments - ]

**THANKS FOR YOUR BUSINESS!**

Vehicle Received: 3/26/2024

Customer Number : 65

Wheel Nuts are torqued to factory specifications & must be rechecked within 100 KMS from time wheels were removed. T&B Fleet Services is not responsible for loss or damage to vehicles or articles left in vehicle in case of fire, theft, or any other cause beyond our control.

Parts Warranty is set by the manufacturer, typically 1 year. Labor Warranty is 90 days and must be performed in our shop and cannot exceed the original cost of repairs.

PAYMENT TERMS: Due Upon Receipt (Net 30 with a charge account). NOTE: if paying by credit card over the phone there will be a 2% charge to total invoice. We do not accept credit card payments over \$5000.

Signature \_\_\_\_\_ Date \_\_\_\_\_

Visit us on the web: [www.tbfleetservices.ca](http://www.tbfleetservices.ca)

Email Address: [info@tbfleetservices.ca](mailto:info@tbfleetservices.ca)



**T&B Fleet Services**  
#2 877 Redonda St.  
Sunnyside, MB. R5R 0J4  
Phone: 204-222-3608  
Fleet Hrail Repairs & Vehicle Service

**INVOICE****3293**

Org. Est. # 002776  
GST #77259 9601 RT0001

**INVOICE**

Printed Date: 04/25/2024

Work Completed: 04/25/2024

**CARIBOO RAILROAD CONTRACTING COR**

117-3030 Pandosy Street  
Kelowna, BC V1Y 0C4  
Work 250-640-0553

2019 Ford - F-550 Super Duty XLT - 6.7L, V8 (406CI) VIN(T)

Lic # :

Odometer In : 208783

Unit # : 55

VIN # : 1FD0W5HT4 KEE14684

Part Description	/ Number	Qty	Sale	Ext	Labor Description	Hours	Ext
fuse BOX ASSY HU5Z 14A067 A		1.00	1,357.07	1,357.07	diagnose no start	2.00	270.00
pigtail WIRE ASSY WPT 1529 Shop Supplies		1.00	297.63	297.63	HEAVY DUTY TOWING 24-148704		230.00
				49.95	FUEL TANK - Remove & Replace - Diesel - [Includes: Drain and fill.] removed tank inspected fuel pump and connectors , replaced tank, all connector and fuel pump no defects at this time	3.03	409.05
					FUSE BOX - Remove & Replace - Battery Junction Box (BJB) - and wire in new pig tail for fuel pump Relay	2.50	337.50
					Enviro Fees		4.50
Taxes							
GST							147.79
PST							206.90

Job Code: MB . CN . UN55 . HR

Task Code: A16NB

Equipment Unit #: 55

Comment: FUEL FUSE BOX

Rec Apr 25/24

Org. Estimate 2.81 Revisions 0.00 Current Estimate 2.81

DocuSigned by:

*Tammy Froehlich*  
C2DEEF0C9EDD4F2...

2024-04-29

Labor:	1,016.55
Parts:	1,704.65
Sublet:	230.00
HazMat:	4.50
<b>SubTotal:</b>	<b>2,955.70</b>
<b>Tax:</b>	<b>354.69</b>
<b>Total:</b>	<b>3,310.39</b>
<b>Bal Due:</b>	<b>\$3,310.39</b>

[ Payments - ]

**THANKS FOR YOUR BUSINESS!**

Vehicle Received: 4/17/2024

Customer Number : 65

Wheel Nuts are torqued to factory specifications & must be rechecked within 100 KMS from time wheels were removed. T&B Fleet Services is not responsible for loss or damage to vehicles or articles left in vehicle in case of fire, theft, or any other cause beyond our control.

Parts Warranty is set by the manufacturer, typically 1 year. Labor Warranty is 90 days and must be performed in our shop and cannot exceed the original cost of repairs.

PAYMENT TERMS: Due Upon Receipt (Net 30 with a charge account). NOTE: If paying by credit card over the phone there will be a 2% charge to total invoice. We do not accept credit card payments over \$7,500.00.

Signature \_\_\_\_\_ Date \_\_\_\_\_

Visit us on the web: www.tbfleetservices.ca

Email Address: info@tbfleetservices.ca



www.tbfleetservices.ca

**T&B Fleet Services**  
 #2 877 Redonda St.  
 Sunnyside, MB. R5R 0J4  
 Phone: 204-222-3608  
 Fleet Hirall Repairs & Vehicle Service

**INVOICE**

**3270**

GST #77259 9601 RT0001

**INVOICE**

Printed Date: 04/15/2024

Work Completed: 04/15/2024

**CARIBOO RAILROAD CONTRACTING COR**  
 117-3030 Pandosy Street  
 Kelowna, BC V1Y 0C4  
 Work 250-640-0553

2019 Ford - F-550 Super Duty XLT - 6.7L, V8 (406CI) VIN(T)  
 Lic # : Odometer In : 208739  
 Unit # : 55  
 VIN # : 1FD0W5HT4 KEE14684

Part Description	Number	Qty	Sale	Ext	Labor Description	Hours	Ext
fuel pump control module xxxx		1.00	89.97	89.97	Heavy duty towing 24-147308		230.00
Power train control module hc3z 12a650bcnp Shop Supplies		1.00	1,881.49	1,881.49	diagnose not start SCANNED DTCS P008A - LOW FUEL PRESSURE U0109 - LOST COMM WITH FUEL PUMP CONTROL MODULE A P064A - FUEL PUMP CONTROL MODULE A P027A - FUEL PUMP CONTROL MODULE B P221C- REDUCTANT HEATER B P2452 - PARTICULATE SENSOR A  REMOVED LEFT FRONT WHEEL LINER TO ACCESS MAIN CONNECTORS FOR PCM, SCR MODULE. NO CORROSION PRESENT IN CONNECTORS. REMOVED FUEL FILTER & INSPECT FOR METAL. NO METAL PRESENT. REMOVED LIFT PUMP TUBE & CHECKED FOR FUEL PRIME WITH KEY ON. NO FUEL PRIME PRESENT. CHECK VOLTAGE AT FUEL PUMP LIFT UNIT. NO VOLTAGE PRESENT. CHECK FUSES & RELAY. OK. CHECKED FUEL PUMP CONTROL UNIT, BATTERY VOLTAGE & PCM SIGNAL PRESENT. NO OUTPUT FROM MODULE. FUEL PUMP MODULE FAULTY. REPLACEMENT REQUIRED. performed pin point test and leads to PCM fault,	5.00	675.00
				49.95			
					FUEL PUMP CONTROL MODULE - Remove & Replace - (FPDM) - [DOES NOT include test.]	1.10	148.50
					PCM/PROCESSOR ASSEMBLY - Remove & Replace - Diesel - [Includes: Programming.]	1.50	202.50
					Enviro Fees		4.50
					Taxes		
					GST		164.10
					PST		229.73



**T&B Fleet Services**  
#2 877 Redonda St.  
Sunnyside, MB. R5R 0J4  
Phone: 204-222-3608  
Fleet Hiraill Repairs & Vehicle Service

**INVOICE****3270**

GST #77259 9601 RT0001

**INVOICE**

Printed Date: 04/15/2024

Work Completed: 04/15/2024

**CARIBOO RAILROAD CONTRACTING COR**

117-3030 Pandosy Street  
Kelowna, BC V1Y 0C4  
Work 250-640-0553

2019 Ford - F-550 Super Duty XLT - 6.7L, V8 (406CI) VIN(T)

Lic # :

Odometer In : 208739

Unit # : 55

VIN # : 1FD0W5HT4 KEE14684

Part Description	/ Number	Qty	Sale	Ext	Labor Description	Hours	Ext
------------------	----------	-----	------	-----	-------------------	-------	-----

**Job Code:** SK . PUREL . KIN . HR**Task Code:** A16NB**Equipment Unit #:** 55**Comment:** PCM

DocuSigned by:

Tammy Froehlich

C2DEEF0C9EDD4F2...

2024-04-16

**Rec Apr 15/24**

Org. Estimate	2.50	Revisions	930.29	Current Estimate	932.79
---------------	------	-----------	--------	------------------	--------

Revision # 1, Previous Estimate Amount: 2.50, Additional Cost: 930.29, Revised Estimate: 932.79, Parts: \$89.97 Labor: \$486.00 Sublet: \$230.00 Taxes & Fees: \$124.32 Authorized by - . Date - 4/11/2024. Time - 2:08 PM. Initiated By - Shop. Written By - Bowlev. Butch

<b>Labor:</b>	<b>1,026.00</b>
<b>Parts:</b>	<b>2,021.41</b>
<b>Sublet:</b>	<b>230.00</b>
<b>HazMat:</b>	<b>4.50</b>
<b>SubTotal:</b>	<b>3,281.91</b>
<b>Tax:</b>	<b>393.83</b>
<b>Total:</b>	<b>3,675.74</b>
<b>Bal Due:</b>	<b>\$3,675.74</b>

[ Payments - ]

**THANKS FOR YOUR BUSINESS!**

Vehicle Received: 4/11/2024

Customer Number : 65

Wheel Nuts are torqued to factory specifications & must be rechecked within 100 KMS from time wheels were removed. T&B Fleet Services is not responsible for loss or damage to vehicles or articles left in vehicle in case of fire, theft, or any other cause beyond our control.

Parts Warranty is set by the manufacturer, typically 1 year. Labor Warranty is 90 days and must be performed in our shop and cannot exceed the original cost of repairs.

PAYMENT TERMS: Due Upon Receipt (Net 30 with a charge account). NOTE: If paying by credit card over the phone there will be a 2% charge to total invoice. We do not accept credit card payments over \$7,500.00.

Signature \_\_\_\_\_ Date \_\_\_\_\_

Visit us on the web: [www.tbfleetservices.ca](http://www.tbfleetservices.ca)Email Address: [info@tbfleetservices.ca](mailto:info@tbfleetservices.ca)

CUSTOMER #:  
UNIT# 55

227188

Terry Ortynsky's  
**ROYAL**  
**FORD**

Phone (306) 782-2261  
Parts (306) 783-8559  
Fax (306) 786-6515  
Email customerservice@royalford.ca  
www.terryortynsky.com  
81 Dracup Avenue  
Yorkton, SK S3N 3P9  
GST# 104644364

\*INVOICE\*

*We Make It Easy!*

CARIBOU RAIL  
209-307 BANKS RD  
KELOWNA, BC V1X 6A1  
HOME: 778-478-1746 CONT: 778-478-1746

PAGE 1

BUS: CELL: SERVICE ADVISOR: 163 MICHELLE CAMPBELL

COLOUR	YEAR	MAKE/MODEL	VIN	LICENSE	ODOMETER IN/ OUT	TAG	
WHITE	19	FORD F550	1FD0W5HT4KEE14684		205966/206029	T4684	
DEL DATE	PROD. DATE	WARR. EXP.	PROMISED	PO NO.	RATE	PAYMENT	INV. DATE
01JAN19 DD			17:00 14MAR24		150.00	DC	15MAR24
R.O. OPENED	READY	OPTIONS: DLR:B4016 1)DRIVING FORCE UNIT - 157912 2)TAMMY-250-640-4557 3)TOM-204-796-0086					
14:58 11MAR24	14:19 15MAR24						

LINE	OPCODE	TECH	TYPE	HOURS	LIST	NET	TOTAL
------	--------	------	------	-------	------	-----	-------

A C/S OVERHEATING ON ACCELERATION OVER 100 KPH							
DIAG C/S OVERHEATING ON ACCELERATION OVER 100 KPH							
				131	CFL	4.49	
				381	CFL	0.00	
						4.49	
				1	YB*3246*	CLUTCH ASY - FAN	648.00
				1	KC3Z*12B637*	A WIRE ASY	1030.04
				1	WT*56814*	KIT - TERMINAL	12.01
				1	DG9Z*14526*	K CIRCUIT BREAKER ASY	0.67
PARTS:	1535.68	LABOR:	718.40	OTHER:	0.00	TOTAL LINE A:	2254.08

205966 CEL on. Self-test PCM. DTC P0495, P0529 and P0691 (all related to cooling fan) present. Inspected and found connector to fan clutch damaged, connector is ripped off. Fan looks ok. No other damage found. Need to replace fan clutch and connector pigtail. Part unavailable. Ordered new clutch and complete engine harness. Removed fan clutch. Found that the rotary connector on the clutch seized, causing it to break from not being able to turn. Replaced clutch. Cut required connector pigtail from new engine harness and repaired vehicle harness with it. Found a lot of debris between radiator and A/C condenser, washed out. Cleared DTCs. Road tested. Fault did not return, vehicle did not overheat.

\*\*\*\*\*

B C/S WHEN DOWNSHIFTING FEELS LIKE THE TRUCK LURCHES AHEAD							
DIAG C/S WHEN DOWNSHIFTING FEELS LIKE THE TRUCK LURCHES AHEAD							
				131	CFL	2.17	347.20
PARTS:	0.00	LABOR:	347.20	OTHER:	0.00	TOTAL LINE B:	347.20

205966 Road tested. Unable to duplicate concern. Transmission up/downshifts properly through all gears with no issues. If engine was overheating, power de-rating may have occurred causing lack of power feel.

\*\*\*\*\*

C DIESEL OIL CHANGE, FLUID TOP UP - SYNTHETIC OIL Y/N - TOP UP DEF Y/N  
- PRE-APPROVAL (\$75 OR LESS) Y/N

TERMS: STRICTLY CASH UNLESS ARRANGEMENTS MADE	ALL ITEMS SUBJECT TO G.S.T.	DESCRIPTION	TOTALS
I HEREBY AUTHORIZE THE REPAIR WORK SET FORTH TO BE DONE ALONG WITH THE NECESSARY MATERIAL AND AGREE TO THE EXTENT PERMITTED BY LAW, YOU ARE NOT RESPONSIBLE FOR LOSS OR DAMAGE TO VEHICLE OR ARTICLES LEFT IN VEHICLE IN THE CASE OF FIRE, THEFT OR ANY OTHER CAUSE BEYOND YOUR CONTROL OR FOR ANY DELAYS CAUSED BY UNAVAILABILITY OF PARTS OR DELAYS IN PARTS SHIPMENTS BY THE SUPPLIER OR TRANSPORTER. I HEREBY GRANT YOU AND OR YOUR EMPLOYEES, PERMISSION TO OPERATE THE VEHICLE HEREIN DESCRIBED ON STREETS, HIGHWAYS OR ELSEWHERE FOR THE PURPOSE OF TESTING AND/OR INSPECTION, UNTIL PAYMENT IN FULL OF THE WITHIN ACCOUNT. I HEREBY ACKNOWLEDGE THE EXISTENCE OF A MECHANIC'S LIEN IN FAVOUR OF THE WITHIN DEALER ON THE VEHICLE DESCRIBED HEREIN IN RESPECT OF THE MATERIAL SUPPLIED AND SERVICES RENDERED UNDER THIS WORK ORDER FOR THE FULL AMOUNT CHARGED THEREFORE I FURTHER ACKNOWLEDGE THAT THE SAID LIEN SHALL CONTINUE IN FORCE AT ALL TIMES, WHETHER THE VEHICLE IS IN MY POSSESSION IT SHALL BE SUBJECT TO REPOSSESSION ON DEMAND BY THE DEALER UNTIL THE WITHIN ACCOUNT IS PAID IN FULL.		LABOUR AMOUNT	
		PARTS AMOUNT	
		GAS, OIL, LUBE	
		SUBLET AMOUNT	
		MISC. CHARGES	
		TOTAL CHARGES	
		LESS INSURANCE	
		SALES TAX	
		PLEASE PAY THIS AMOUNT	

PRIVACY

Personal information is collected in accordance with applicable privacy legislation and is governed by Terry Ortynsky Ford Privacy Policy. Ask us if you would like information about our Privacy Policy, including our service providers and their data processing in the U.S., which may be accessible to U.S. law enforcement and national security authorities.

We provide this personal and transaction information to Ford Motor Company of Canada, Limited to enable Ford to administer your transaction, provide you with requested services, improve automotive related products and services by conducting customer surveys, and provide you with marketing material which may be of interest to you, as permitted by applicable laws. For the Ford Privacy Policy (www.ford.ca) including use of service providers and U.S. data storage or if you do not want to receive marketing or survey materials from Ford please call 1-800-565-FORD (38731).

INDEBTEDNESS IS HEREBY ACKNOWLEDGED IN THE SUM OF \$ \_\_\_\_\_ BEING ALL OR THE BALANCE OWING FOR REPAIRS, PARTS AND ACCESSORIES DESCRIBED IN THIS WORK ORDER. ALL WARRANTY SUBJECT TO FACTORY ACCEPTANCE. DATE \_\_\_\_\_ SIGNATURE \_\_\_\_\_

CUSTOMER COPY

CUSTOMER #:  
UNIT# 55

227188

Terry Ortynsky's  
**ROYAL**  
**FORD**

Phone (306) 782-2261  
Parts (306) 783-8559  
Fax (306) 786-6515  
Email customerservice@royalford.ca  
www.terryortynsky.com  
81 Dracup Avenue  
Yorkton, SK S3N 3P9  
GST# 104644364

\*INVOICE\*

*We Make It Easy!*

CARIBOU RAIL  
209-307 BANKS RD  
KELOWNA, BC V1X 6A1  
HOME: 778-478-1746 CONT: 778-478-1746

PAGE 2

BUS: CELL: SERVICE ADVISOR: 163 MICHELLE CAMPBELL

COLOUR	YEAR	MAKE/MODEL	VIN	LICENSE	ODOMETER IN/ OUT	TAG
WHITE	19	FORD F550	1FD0W5HT4KEE14684		205966/206029	T4684

DEL DATE	PROD. DATE	WARR. EXP.	PROMISED	PO NO.	RATE	PAYMENT	INV. DATE
01JAN19 DD			17:00 14MAR24		150.00	DC	15MAR24

R.O. OPENED	READY	OPTIONS:
14:58 11MAR24	14:19 15MAR24	DLR:B4016 1)DRIVING FORCE UNIT - 157912 2)TAMMY-250-640-4557 3)TOM-204-796-0086

LINE	OPCODE	TECH	TYPE	HOURS	LIST	NET	TOTAL
------	--------	------	------	-------	------	-----	-------

QLM1D DIESEL OIL CHANGE, FLUID TOP UP - SYNTHETIC  
OIL Y/N - TOP UP DEF Y/N - PRE-APPROVAL (\$75  
OR LESS) Y/N

381 CQL 0.88		54.99	54.99
ENV ENVIRONMENTAL CHARGE		4.00	4.00
1 FA*1927* ELEMENT ASY - AIR CL	213.91	213.91	213.91
1 FL*2124*S KIT - ELEMENT & GASK	65.62	65.62	65.62
12 CXO*10W30*BSD OIL - ENGINE	7.68	7.68	92.16
10 PM27D1L DEF	1.95	1.95	19.50

PARTS: 391.19 LABOR: 54.99 OTHER: 4.00 TOTAL LINE C: 450.18

205966

Performed the oil change with Fords recommended synthetic blend unless customer specified full synthetic and inspected tires. The tires measure 18/32 in the front and 17/32 in the rear. Brake measurements not taken during this visit. Checked all fluids and topped up as required including Diesel Exhaust Fluid. Completed the Vehicle Report Card - attached for your records. Coolant tested at -41 C. CEL IS ONN

CHIP MARKS ON WINDSHEILD

\*\*\*\*\*YOUR NEXT RECOMMENDED MAINTENANCE IS 213966

\*\*\*\*\*

D FUEL FILTER

QLFUE FUEL FILTER

381 CQL 0.65		70.00	70.00
1 FD*4641* ELEMENT	172.53	172.53	172.53

PARTS: 172.53 LABOR: 70.00 OTHER: 0.00 TOTAL LINE D: 242.53

205966 REPLACED FUEL FILTERS

\*\*\*\*\*

E\*\* REPLACE PSP LINE PER DIAG

98 MISC

353 ISP 5.14			(N/C)
1 PSH*383* HOSE ASY			(N/C)
1 CXT*5*LM6 ADDITIVE - OIL - FRI			(N/C)

PARTS: 0.00 LABOR: 0.00 OTHER: 0.00 TOTAL LINE E: 0.00

TERMS: STRICTLY CASH UNLESS ARRANGEMENTS MADE	ALL ITEMS SUBJECT TO G.S.T.	DESCRIPTION	TOTALS
I HEREBY AUTHORIZE THE REPAIR WORK SET FORTH TO BE DONE ALONG WITH THE NECESSARY MATERIAL AND AGREE TO THE EXTENT PERMITTED BY LAW, YOU ARE NOT RESPONSIBLE FOR LOSS OR DAMAGE TO VEHICLE OR ARTICLES LEFT IN VEHICLE IN THE CASE OF FIRE, THEFT OR ANY OTHER CAUSE BEYOND YOUR CONTROL OR FOR ANY DELAYS CAUSED BY UNAVAILABILITY OF PARTS OR DELAYS IN PARTS SHIPMENTS BY THE SUPPLIER OR TRANSPORTER. I HEREBY GRANT YOU AND OR YOUR EMPLOYEES, PERMISSION TO OPERATE THE VEHICLE HEREIN DESCRIBED ON STREETS, HIGHWAYS OR ELSEWHERE FOR THE PURPOSE OF TESTING AND/OR INSPECTION, UNTIL PAYMENT IN FULL OF THE WITHIN ACCOUNT. I HEREBY ACKNOWLEDGE THE EXISTENCE OF A MECHANIC'S LIEN IN FAVOUR OF THE WITHIN DEALER ON THE VEHICLE DESCRIBED HEREIN IN RESPECT OF THE MATERIAL SUPPLIED AND SERVICES RENDERED UNDER THIS WORK ORDER FOR THE FULL AMOUNT CHARGED THEREFORE. I FURTHER ACKNOWLEDGE THAT THE SAID LIEN SHALL CONTINUE IN FORCE AT ALL TIMES, WHETHER THE VEHICLE IS IN MY POSSESSION IT SHALL BE SUBJECT TO REPOSSESSION ON DEMAND BY THE DEALER UNTIL THE WITHIN ACCOUNT IS PAID IN FULL.		LABOUR AMOUNT	
		PARTS AMOUNT	
		GAS, OIL, LUBE	
		SUBLET AMOUNT	
		MISC. CHARGES	
		TOTAL CHARGES	
		LESS INSURANCE	
		SALES TAX	
		<b>PLEASE PAY THIS AMOUNT</b>	

PRIVACY  
Personal information is collected in accordance with applicable privacy legislation and is governed by Terry Ortynsky Ford Privacy Policy. Ask us if you would like information about our Privacy Policy, including our service providers and their data processing in the U.S., which may be accessible to U.S. law enforcement and national security authorities. We provide this personal and transaction information to Ford Motor Company of Canada, Limited to enable Ford to administer your transaction, provide you with requested services, improve automotive related products and services by conducting customer surveys, and provide you with marketing material which may be of interest to you, as permitted by applicable laws. For the Ford Privacy Policy (www.ford.ca) including use of service providers and U.S. data storage or if you do not want to receive marketing or survey materials from Ford please call 1-800-585-FORD (3673).

INDEBTEDNESS IS HEREBY ACKNOWLEDGED IN THE SUM OF \$ \_\_\_\_\_ BEING ALL OR THE BALANCE OWING FOR REPAIRS, PARTS AND ACCESSORIES DESCRIBED IN THIS WORK ORDER. ALL WARRANTY SUBJECT TO FACTORY ACCEPTANCE. DATE \_\_\_\_\_ SIGNATURE \_\_\_\_\_

CUSTOMER COPY

CUSTOMER #: UNIT# 55

227188

Terry Ortynsky's ROYAL FORD

Phone (306) 782-2261 Parts (306) 783-8559 Fax (306) 786-6515 Email customerservice@royalford.ca www.terryortynsky.com 81 Dracup Avenue Yorkton, SK S3N 3P9 GST# 104644364

\*INVOICE\*

We Make It Easy!

PAGE 3

CARIBOU RAIL 209-307 BANKS RD KELOWNA, BC V1X 6A1 HOME:778-478-1746 CONT:778-478-1746 BUS: CELL:

SERVICE ADVISOR: 163 MICHELLE CAMPBELL

Table with columns: COLOUR, YEAR, MAKE/MODEL, VIN, LICENSE, ODOMETER IN/ OUT, TAG. Includes details for WHITE 19 FORD F550 and various dates and rates.

Table with columns: LINE, OPCODE, TECH, TYPE, HOURS, LIST, NET, TOTAL. Includes 'REPLACE POWER STEERING LINE' and '98 MISC' items.

PARTS: 205966 replaced high pressure power steering hose steering fluid topped up wheels torque to 165 ft lbs road test wheels re torque checked no leak and checked power steering fluid still up to max done

\*\*\*\*\*

ESTIMATE: 162.61 11MAR24 14:58 SA: 163 CONTACT:

SHOP SUPPLIES Job Code: BC.CN.UN55.HR 75.00

Task Code: A16NB

Equipment Unit #: 55

Comment: LOF, FAN HUB, TRANS

DocuSigned by: Tammy Froelich C2DEEF0C9EDD4F2... 2024-03-20

Rec Mar 15/24

GST PST (#: R104644364) 205.27 246.32

Table with columns: TERMS, ALL ITEMS SUBJECT TO G.S.T., DESCRIPTION, TOTALS. Includes 'STRICTLY CASH UNLESS ARRANGEMENTS MADE' and a summary of charges totaling 4557.36.

INDEBTEDNESS IS HEREBY ACKNOWLEDGED IN THE SUM OF \$ BEING ALL OR THE BALANCE OWING FOR REPAIRS, PARTS AND ACCESSORIES DESCRIBED IN THIS WORK ORDER. ALL WARRANTY SUBJECT TO FACTORY ACCEPTANCE. DATE SIGNATURE CUSTOMER COPY

MULTI-POINT INSPECTION

Date: 03/11/2024 RO#: 227188  
 Name: CARIBOU RAIL  
 Odometer: 205966  
 FPR/LAR Member#: \_\_\_\_\_ Points Balance: \_\_\_\_\_

LEGEND  May contribute to vehicle efficiency and promote a greener environment  
 Checked and OK at this time  Requires future attention  Requires immediate attention

Checked and completed open field service actions (recalls)

SCHEDULED MAINTENANCE ITEMS DUE*			
DUE	SERVICED	DUE	SERVICED
<input type="checkbox"/> The Works	<input type="checkbox"/>	<input checked="" type="checkbox"/> Engine Air Filter	<input type="checkbox"/>
<input checked="" type="checkbox"/> Oil & Filter Change and Reset	<input type="checkbox"/>	<input type="checkbox"/> Engine Coolant	<input type="checkbox"/>
<input checked="" type="checkbox"/> Tire Rotation - n/a in QC!	<input type="checkbox"/>	<input checked="" type="checkbox"/> Transmission Fluid &/or Filter	<input type="checkbox"/>
<input type="checkbox"/> Multi-Point Inspection	<input type="checkbox"/>	<input type="checkbox"/> Cabin Air Filter	<input type="checkbox"/>
<input type="checkbox"/> Fuel Filter	<input type="checkbox"/>	<input type="checkbox"/> Spark Plugs	<input type="checkbox"/>
_____ km Scheduled Maintenance		<input type="checkbox"/>	

\*This is only a partial list of vehicle maintenance items and is NOT all-inclusive. Please consult your Owner's Manual for vehicle-specific maintenance requirements.

FLUID LEVELS		SERVICED
<input checked="" type="checkbox"/> Oil and/or fluid leaks		<input type="checkbox"/>

OK <input checked="" type="checkbox"/> FILL <input type="checkbox"/> Engine Oil	OK <input checked="" type="checkbox"/> FILL <input type="checkbox"/> Power Steering	OK <input checked="" type="checkbox"/> FILL <input type="checkbox"/> Transmission (if equipped with d.pstick)
<input checked="" type="checkbox"/> Brake Reservoir	<input checked="" type="checkbox"/> Window Washer	<input checked="" type="checkbox"/> Coolant Recovery Reservoir

WIPER BLADES		SERVICED
<input checked="" type="checkbox"/> Wiper Test Performed	<input checked="" type="checkbox"/> Wiper Blades	<input type="checkbox"/>

BATTERY		SERVICED
State of Health	Battery Condition <input checked="" type="checkbox"/>	<input type="checkbox"/>

Factory spec cold cranking amps 850 Actual cold cranking amps 882

VISUAL CASUAL INSPECTION		SERVICED
<input checked="" type="checkbox"/> Air filter restriction gauge and housing		<input type="checkbox"/>
<input checked="" type="checkbox"/> Water in fuel dash light		<input type="checkbox"/>
<input checked="" type="checkbox"/> Charge air cooling piping and air intake system		<input type="checkbox"/>
<input checked="" type="checkbox"/> Turbocharger		<input type="checkbox"/>

**EXTERIOR BODY**

Note any existing exterior body damage or defects on diagram

SYSTEMS / COMPONENTS		SERVICED
<b>LIGHTS / WINDSHIELD</b>		
<input checked="" type="checkbox"/> Operation of horn, interior lights, exterior lamps, turn signals, hazard and brake lamps		<input type="checkbox"/>
<input checked="" type="checkbox"/> Windshield for cracks, chips and pitting		<input type="checkbox"/>
<b>BELTS / HOSES / MOUNTS</b>		
<input checked="" type="checkbox"/> HVAC system and hoses / lines for leaks and/or damage		<input type="checkbox"/>
<input checked="" type="checkbox"/> Engine Cooling System, radiator, hoses and clamps		<input type="checkbox"/>
<input checked="" type="checkbox"/> Accessory drive belt(s)		<input type="checkbox"/>
<b>BRAKE SYSTEM</b>		
<input checked="" type="checkbox"/> Brake system (including lines, hoses and parking brake)		<input type="checkbox"/>
<b>STEERING / SUSPENSION</b>		
<input checked="" type="checkbox"/> Shocks / struts and other suspension components for leaks and/or damage		<input type="checkbox"/>
<input checked="" type="checkbox"/> Steering, steering linkages and ball joints (visual)		<input type="checkbox"/>
<b>EXHAUST SYSTEM</b>		
<input checked="" type="checkbox"/> Exhaust system (leaks, damage, loose parts)		<input type="checkbox"/>
<b>TRANSMISSION / DRIVE AXLE</b>		
<input checked="" type="checkbox"/> Clutch operations (if equipped)		<input type="checkbox"/>
<input checked="" type="checkbox"/> Constant velocity (CV) drive axle boots (if equipped)		<input type="checkbox"/>
<input checked="" type="checkbox"/> Drive shaft, transmission, u-joint and shift linkage (if equipped) and lubricate (as needed)		<input type="checkbox"/>

TIRE / BRAKE WEAR			
TIRE TREAD	7/32" and greater	4/32" to 6/32"	3/32" and less
BRAKE LINING	Over 5 mm or 7/32" (Disc) or eyed 2 mm or 3/32" (Drum)	3 to 5 mm or 4/32" to 7/32" (Disc) or 1 to 2 mm or 2/32" to 3/32" (Drum)	Less than 3 mm or 4/32" (Disc) or less than 1 mm or 2/32" (Drum)

TIRE WEAR INDICATES		COMMENTS	
SERVICED	SERVICED		
<input type="checkbox"/> Alignment check needed	<input type="checkbox"/> Wheel balance needed		
<b>LEFT FRONT</b>		<b>RIGHT FRONT</b>	
<input checked="" type="checkbox"/> Tire Tread Depth <u>16</u> /32" Tire Age <u>&lt;5yr</u>	<input checked="" type="checkbox"/> Tire Tread Depth <u>16</u> /32" Tire Age <u>&lt;5yr</u>		
<input checked="" type="checkbox"/> Tire Wear Pattern / Damage	<input checked="" type="checkbox"/> Tire Wear Pattern / Damage		
<input checked="" type="checkbox"/> Tire Pressure set to factory-recommended PSI	<input checked="" type="checkbox"/> Tire Pressure set to factory-recommended PSI		
<b>LEFT REAR</b>		<b>RIGHT REAR</b>	
<input checked="" type="checkbox"/> Tire Tread Depth <u>15</u> /32" Tire Age <u>&lt;5yr</u>	<input checked="" type="checkbox"/> Tire Tread Depth <u>15</u> /32" Tire Age <u>&lt;5yr</u>		
<input checked="" type="checkbox"/> Tire Wear Pattern / Damage	<input checked="" type="checkbox"/> Tire Wear Pattern / Damage		
<input checked="" type="checkbox"/> Tire Pressure set to factory-recommended PSI	<input checked="" type="checkbox"/> Tire Pressure set to factory-recommended PSI		
<b>SPARE TIRE</b>			
<input checked="" type="checkbox"/> Tire Pressure set to factory-recommended PSI	<input type="checkbox"/> Tire Age <u>&lt;5yr</u>	Tires should be replaced after six years regardless of treadwear, including the spare, even if it has not been used.	

BRAKE WEAR INDICATES			
<input checked="" type="checkbox"/> Brake measurements not taken this service visit			
SERVICED	SERVICED	SERVICED	SERVICED
<input type="checkbox"/> Brake Lining <u>N/C</u> mm _____ /32"	<input type="checkbox"/> Brake Lining <u>N/C</u> mm _____ /32"	<input type="checkbox"/> Brake Lining <u>N/C</u> mm _____ /32"	<input type="checkbox"/> Brake Lining <u>N/C</u> mm _____ /32"
<input type="checkbox"/> Brake Lining <u>N/C</u> mm _____ /32"	<input type="checkbox"/> Brake Lining <u>N/C</u> mm _____ /32"	<input type="checkbox"/> Brake Lining <u>N/C</u> mm _____ /32"	<input type="checkbox"/> Brake Lining <u>N/C</u> mm _____ /32"

Service Advisor Michelle Campbell  
 Technician Harvijay Grewal  
 Customer Signature \_\_\_\_\_  
 Customer Declined Recommended Maintenance  
 Your Next Maintenance  
 Mileage \_\_\_\_\_ OR Time \_\_\_\_\_  
 \*Tire rotation not included as part of The Works in Quebec.  
 REV 05/21 ©2021 Ford Motor Company of Canada, Limited. All Rights Reserved QL-550-E



**WINDSOR FORD**  
 10001 139 Avenue • Grande Prairie, AB • T8X 0V3  
 Tel: (780) 532-9555 • 1-800-422-6094  
 service@windsorford.com • www.windsorford.com  
 SERVICE HOURS - Mon - Sat 7:15 a.m. - 6:00 p.m.

**GENUINE PEOPLE  
 TREATING YOU LIKE  
 A PERSON**

**OUR REPUTATION IS  
 YOUR EXPERIENCE**

**SO# 564131**

**SERVICE ORDER  
 CUSTOMER COPY**



Printed 01/24/2024 10:26:40 AM

User 1264 Page 1

<b>Customer No</b> CARIBOO RAILROAD CONTRACTING CORP. 3030 PANDOSY Unit #117 KELOWNA, BC V1Y 0C4	<b>Advisor</b> Shayna D <b>Shop</b> WF <b>Priority</b>	<b>Promised</b> 10/25/2023 6:30 PM <b>Opened</b> 10/20/2023 4:57 PM <b>Cashiered</b> 11/24/2023 4:44 PM	2721 <b>Location</b> <b>PO #</b> AB.UNIT55.GP
<b>Home</b> <b>Cell</b> <b>Email</b>	<b>Bus</b> (778) 478-1745 <b>Today</b>	<b>License</b> 739LLQ <b>Year</b> 2019 <b>Make</b> FORD <b>Vehicle ID No</b> 1FD0W5HT4KEE14684 <b>Engine</b> 6.7L 4V OHV POWER STROKE V8	<b>Odom In</b> 194792 <b>Odom Out</b> 194792 <b>Model</b> SUPER DUTY F-550 DRW W5H <b>Selling Dealer</b> <b>Extended Warranty</b> 55
<b>Term</b> CHARGE		<b>In Service Date</b>	<b>Stock No</b> OXFORD <b>Colour</b> <b>Delivery Date</b>

Request	Description	Job	CSR	Status			
130	power steering pump is leaking	1	SHAYNA	Original			
Labour	Description	Type	Amount				
130	power steering pump is leaking	CD	780.00				
Part	Description	Shp	Bin	Type	Retail	Price	Amount
CXT 10 LV6	FLUID - TRANSMISSION	2	WH1	CR16	10.92	10.92	21.84
ENOIL	ENVIRO FEE OIL	2	SPORD	CR16	0.10	0.10	0.20
BRB 311	BOOSTER ASY - BRAKE	1	B3	CR16	670.65	670.65	670.65
Technician	4 -			Parts Total			692.69
Cause	Inspect for power steering leaking, found leak at Hydroboost. Replacement required.			Labour Total			780.00
Correction	Install new Hydroboost unit, top up oil and wash affected area. Retest good			<b>Request Sub-total</b>			<b>1,472.69</b>

Request	Description	Job	CSR	Status			
120	check front brakes, shimmy	2	SHAYNA	Original			
Labour	Description	Type	Amount				
120	check front brakes, shimmy	CD	1,657.50				
Part	Description	Shp	Bin	Type	Retail	Price	Amount
BRF 2011	KIT - BRAKE LINING	1	B3	CR16	299.91	299.91	299.91
STK	ROTOR ASY - BRAKE	2	C3	CR16	409.00	409.00	818.00
BRF 1976	PAD - BRAKE	1	B3	CR16	315.69	315.69	315.69
BRF 1971	ROTOR ASY - BRAKE	2	C2	CR16	479.70	479.70	959.40
BRS 190	SEAL	2	B1D	CR16	83.90	83.90	167.80
WE SHOW 1	RING - SEALING	2	D1D	CR16	7.54	7.54	15.08
Technician	4 -			Parts Total			2,575.88
				Labour Total			1,657.50

**TERMS: STRICTLY CASH UNLESS ARRANGEMENTS ARE MADE.** "I hereby authorize the repair work hereinafter to be done along with the necessary material and agree that you are not responsible for loss or damage to vehicle or articles left in the vehicle in case of fire, theft, or any other cause beyond your control or for any delays caused by unavailability of parts or delays in parts shipments by the supplier or transporter. I hereby grant you or your employees permission to operate the vehicle herein described on streets, highways, or elsewhere for the purpose of testing and/or inspection. An express mechanic's lien is hereby acknowledged on above vehicle to secure the amount of repairs thereto."

**DISCLAIMER OF WARRANTIES:** Any warranties on the products sold hereby are those made by the manufacturer. The seller hereby expressly disclaims all warranties either express or implied, including any implied warranty of merchantability or fitness for a particular purpose, and the seller neither assumes or authorizes any other person to assume for it any liability in connection with the sale of said products. Any limitation contained herein does not apply where prohibited by law.

**PRIVACY STATEMENT:** Personal information is collected in accordance with applicable privacy legislation and is governed by the Dealer's Privacy Policy. Your privacy is important to us. Ask us if you would like information about our Privacy Policy. We provide this personal information to Ford Motor Company of Canada Limited (together with third parties acting on its behalf "Ford") to enable Ford to administer your transaction, to provide you with services, to improve automotive related products and services by conducting customer surveys, and to provide you with marketing material which may be of interest to you. To obtain the Ford Privacy Policy or if you do not want to receive marketing or survey materials from Ford please call 1-800-565-FORD (3673).

**NO RETURN ON ELECTRICAL OR SAFETY ITEMS OR SPECIAL ORDERS**

**DISCLAIMER:** Wheel lug nuts must be retorqued 100km after any wheel has been removed. This is the CUSTOMERS responsibility.

Customer Signature: \_\_\_\_\_

GST# 10570 8457 RT0001

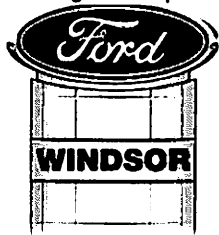

**WINDSOR FORD**  
 10001 139 Avenue • Grande Prairie, AB • T8X 0V3  
 Tel: (780) 532-9555 • 1-800-422-6094  
 service@windsorford.com • www.windsorford.com  
 SERVICE HOURS - Mon - Sat 7:15 a.m. - 6:00 p.m.

**GENUINE PEOPLE  
 TREATING YOU LIKE  
 A PERSON**

**OUR REPUTATION IS  
 YOUR EXPERIENCE**

**SO# 564131**

**SERVICE ORDER  
 CUSTOMER COPY**



Printed 01/24/2024 10:26:40 AM

User 1264 Page 2

<b>Customer No</b>		<b>Advisor</b> Shayna D	<b>Promised</b> 10/25/2023 6:30 PM	2721
CARIBOO RAILROAD CONTRACTING CORP. 3030 PANDOSY Unit #117 KELOWNA, BC V1Y 0C4		<b>Shop</b> WF	<b>Opened</b> 10/20/2023 4:57 PM	<b>Location</b>
<b>Home</b>		<b>Priority</b>	<b>Cashiered</b> 11/24/2023 4:44 PM	<b>PO #</b> AB.UNIT55.GP
<b>Bus (778) 478-1745</b>		<b>License</b> 739LLQ	<b>Odom In</b> 194792	<b>Odom Out</b> 194792
<b>Cell</b>		<b>Year</b> 2019	<b>Make</b> FORD	<b>Model</b> SUPER DUTY F-550 DRW W5H
<b>Email</b>		<b>Vehicle ID No</b> 1FD0W5HT4KEE14684	<b>Selling Dealer</b>	<b>Extended Warranty</b>
<b>Term CHARGE</b>		<b>Engine</b> 6.7L 4V OHV POWER STROKE V8	<b>In Service Date</b>	<b>Stock No</b> 55
		<b>Model Number</b>	<b>Colour</b> OXFORD	<b>Delivery Date</b>

**Cause** Inspect brakes, front brake rotors warped and pads are 2mm. Rear brakes are 4mm. Recommend pads and rotors all around. **Request Sub-total** 4,233.38

**Correction** Install new front pads and rotors, rear pads and rotors, hub seals and top up rear diff oil.

Request	Description	Job	CSR	Status			
150	check fuel pump, needs to sit sometimes before turning over	3	SHAYNA	Original			
Labour	Description	Type	Amount				
150	check fuel pump, needs to sit sometimes before turning over	CD	195.00				
Part	Description	Shp	Bin	Type	Retail	Price	Amount
BXT 65 850	BATTERY	2	D5	CR16	253.20	253.20	506.40
Technician	4 -			Parts Total			506.40
<b>Cause</b>	Inspect for sometimes engine just clicks instead of turning over. Load test both batteries, found left ok and right fails. Recommend replacing both batteries			Labour Total			195.00
<b>Correction</b>	Install two new batteries, customer to monitor if concern returns.			<b>Request Sub-total</b>			<b>701.40</b>

Request	Description	Job	CSR	Status			
125A	tire check may need rotation	4	SHAYNA	Original			
Labour	Description	Type	Amount				
125A	tire check may need rotation	C	501.20				
125A	tire check may need rotation	CQL	80.00				
Part	Description	Shp	Bin	Type	Retail	Price	Amount
9766 23134	XDS2 LT245/70R19.5 H	1	SPORD	CQL16	770.00	770.00	770.00
TIRETAX	ENVIRO TIRE LEVY	1	SPORD	CQL16	4.00	4.00	4.00
MEF 619	END - SPINDLE ROD CO	1	D4	CR16	340.22	340.22	340.22
STK				Parts Total			1,114.22
Technician	4 - 1350 -			Labour Total			581.20
<b>Cause</b>	Inspect for rotation, different tires front and rear, not possible to rotate. Right front tire requires replacement (belt shift).			<b>Request Sub-total</b>			<b>1,695.42</b>

**TERMS: STRICTLY CASH UNLESS ARRANGEMENTS ARE MADE.** "I hereby authorize the repair work hereinafter to be done along with the necessary material and agree that you are not responsible for loss or damage to vehicle or articles left in the vehicle in case of fire, theft, or any other cause beyond your control or for any delays caused by unavailability of parts or delays in parts shipments by the supplier or transporter. I hereby grant you or your employees permission to operate the vehicle herein described on streets, highways, or elsewhere for the purpose of testing and/or inspection. An express mechanic's lien is hereby acknowledged on above vehicle to secure the amount of repairs thereto."

**DISCLAIMER OF WARRANTIES:** Any warranties on the products sold hereby are those made by the manufacturer. The seller hereby expressly disclaims all warranties either express or implied, including any implied warranty of merchantability or fitness for a particular purpose, and the seller neither assumes or authorizes any other person to assume for it any liability in connection with the sale of said products. Any limitation contained herein does not apply where prohibited by law.

**PRIVACY STATEMENT:** Personal information is collected in accordance with applicable privacy legislation and is governed by the Dealer's Privacy Policy. Your privacy is important to us. Ask us if you would like information about our Privacy Policy. We provide this personal information to Ford Motor Company of Canada Limited (together with third parties acting on its behalf "Ford") to enable Ford to administer your transaction, to provide you with services, to improve automotive related products and services by conducting customer surveys, and to provide you with marketing material which may be of interest to you. To obtain the Ford Privacy Policy or if you do not want to receive marketing or survey materials from Ford please call 1-800-565-FORD (3673).

**NO RETURN ON ELECTRICAL OR SAFETY ITEMS OR SPECIAL ORDERS**

**DISCLAIMER:** Wheel lug nuts must be retorqued 100km after any wheel has been removed. This is the CUSTOMERS responsibility.

Customer Signature: \_\_\_\_\_

GST# 10570 8457 RT0001



**WINDSOR FORD**  
 10001 139 Avenue • Grande Prairie, AB • T8X 0V3  
 Tel: (780) 532-9555 • 1-800-422-6094  
 service@windsorford.com • www.windsorford.com  
 SERVICE HOURS - Mon - Sat 7:15 a.m. - 6:00 p.m.

**GENUINE PEOPLE  
 TREATING YOU LIKE  
 A PERSON**

**OUR REPUTATION IS  
 YOUR EXPERIENCE**

**SO# 564131**

**SERVICE ORDER  
 CUSTOMER COPY**



Printed 01/24/2024 10:26:40 AM

User 1264 Page 3

<b>Customer No</b>		<b>Advisor</b> Shayna D	<b>Promised</b> 10/25/2023 6:30 PM	2721
CARIBOO RAILROAD CONTRACTING CORP. 3030 PANDOSY Unit #117 KELOWNA, BC V1Y 0C4		<b>Shop</b> WF	<b>Opened</b> 10/20/2023 4:57 PM	<b>Location</b>
<b>Home Cell</b>	<b>Bus Today</b> (778) 478-1745	<b>Priority</b>	<b>Cashiered</b> 11/24/2023 4:44 PM	<b>PO #</b> AB.UNIT55.GP
<b>Term</b> CHARGE		<b>License</b> 739LLQ	<b>Odom In</b> 194792	<b>Odom Out</b> 194792
		<b>Year Make</b> 2019 FORD	<b>Model</b> SUPER DUTY F-550 DRW W5H	<b>In Service Date</b>
		<b>Vehicle ID No</b> 1FD0W5HT4KEE14684	<b>Selling Dealer</b>	<b>Extended Warranty</b> 55
		<b>Engine</b> 6.7L 4V OHV POWER STROKE V8		<b>Stock No</b>
				<b>Colour</b> OXFORD
				<b>Delivery Date</b>

Correction MOUNTED 2 TIRES  
 PUT BLANCING BEADS IN EACH TIRE  
 FILLED TO 90PSI  
 Installed new right outer tierod end. Wheel alignment

Request	Description	Job	CSR	Status
1004	Gold Clean Exterior wash and shammy dry Tire shine Windows Interior: Wipe down doors and dash Vacuum Spot clean seats and carpet Windows	5	SHAYNA	Original
	Additional Options: Engine Shampoo -\$49.99 : Odor removal- \$39.99 : Pet hair removal by quote : Undercarriage wash starting at \$149.99 per HR			
Labour	Description	Type	Amount	
1004	Gold Clean Exterior wash and shammy dry Tire shine Windows Interior: Wipe down doors and dash Vacuum Spot clean seats and carpet Windows	CDETAIL	179.99	
	Additional Options: Engine Shampoo -\$49.99 : Odor removal- \$39.99 : Pet hair removal by quote : Undercarriage wash starting at \$149.99 per HR			
Technician	KC -		Labour Total	179.99
Correction	perform Base Clean- Automatic carwash- Shammy dry, wipe doors and dash- spot vacuum and clean windows		<b>Request Sub-total</b>	<b>179.99</b>

Request	Description	Job	CSR	Status
888	CUSTOMER INFORMATION/CONTACT# __larry 204-761-8885__	6	SHAYNA	Original
	CUSTOMER'S PREFERRED METHOD OF CONTACT: TEXT _____ CALL _____ EMAIL _____			
	ENGINE HOURS _____			

TERMS: STRICTLY CASH UNLESS ARRANGEMENTS ARE MADE. "I hereby authorize the repair work hereinafter to be done along with the necessary material and agree that you are not responsible for loss or damage to vehicle or articles left in the vehicle in case of fire, theft, or any other cause beyond your control or for any delays caused by unavailability of parts or delays in parts shipments by the supplier or transporter. I hereby grant you or your employees permission to operate the vehicle herein described on streets, highways, or elsewhere for the purpose of testing and/or inspection. An express mechanic's lien is hereby acknowledged on above vehicle to secure the amount of repairs thereto."

DISCLAIMER OF WARRANTIES: Any warranties on the products sold hereby are those made by the manufacturer. The seller hereby expressly disclaims all warranties either express or implied, including any implied warranty of merchantability or fitness for a particular purpose, and the seller neither assumes or authorizes any other person to assume for it any liability in connection with the sale of said products. Any limitation contained herein does not apply where prohibited by law.

PRIVACY STATEMENT: Personal information is collected in accordance with applicable privacy legislation and is governed by the Dealer's Privacy Policy. Your privacy is important to us. Ask us if you would like information about our Privacy Policy. We provide this personal information to Ford Motor Company of Canada Limited (together with third parties acting on its behalf "Ford") to enable Ford to administer your transaction, to provide you with services, to improve automotive related products and services by conducting customer surveys, and to provide you with marketing material which may be of interest to you. To obtain the Ford Privacy Policy or if you do not want to receive marketing or survey materials from Ford please call 1-800-565-FORD (3673).

NO RETURN ON ELECTRICAL OR SAFETY ITEMS OR SPECIAL ORDERS

DISCLAIMER: Wheel lug nuts must be retorqued 100km after any wheel has been removed. This is the CUSTOMERS responsibility.

Customer Signature: \_\_\_\_\_

GST# 10570 8457 RT0001



**WINDSOR FORD**  
 10001 139 Avenue • Grande Prairie, AB • T8X 0V3  
 Tel: (780) 532-9555 • 1-800-422-6094  
 service@windsorford.com • www.windsorford.com  
 SERVICE HOURS - Mon - Sat 7:15 a.m. - 6:00 p.m.

**GENUINE PEOPLE  
 TREATING YOU LIKE  
 A PERSON**

**OUR REPUTATION IS  
 YOUR EXPERIENCE**

**SO# 564131**

**SERVICE ORDER  
 CUSTOMER COPY**



Printed 01/24/2024 10:26:40 AM

User 1264 Page 4

**Customer No**  
 CARIBOO RAILROAD CONTRACTING CORP.  
 3030 PANDOSY Unit #117  
 KELOWNA, BC V1Y 0C4

**Home Cell Email**      **Bus Today** (778) 478-1745

**Term CHARGE**

<b>Advisor</b> Shayna D	<b>Promised</b> 10/25/2023 6:30 PM	2721
<b>Shop</b> WF	<b>Opened</b> 10/20/2023 4:57 PM	<b>Location</b>
<b>Priority</b>	<b>Cashiered</b> 11/24/2023 4:44 PM	<b>PO #</b> AB.UNIT55.GP

<b>License</b> 739LLQ	<b>Odom In</b> 194792	<b>Odom Out</b> 194792	<b>In Service Date</b>	<b>Stock No</b>
<b>Year Make</b> 2019 FORD	<b>Model</b> SUPER DUTY F-550 DRW	<b>Model Number</b> W5H	<b>Colour</b> OXFORD	
<b>Vehicle ID No</b> 1FD0W5HT4KEE14684	<b>Selling Dealer</b>	<b>Extended Warranty</b>	<b>Delivery Date</b>	
<b>Engine</b> 6.7L 4V OHV POWER STROKE V8		55		

Labour	Description	Type	Amount
888	CUSTOMER INFORMATION/CONTACT# _____ Larry 204-761-8885 _____	CQL	0.00

CUSTOMER'S PREFERRED METHOD OF CONTACT:  
 TEXT \_\_\_\_\_ CALL \_\_\_\_\_ EMAIL \_\_\_\_\_

ENGINE HOURS \_\_\_\_\_

Technician 999 -

Request	Description	Job	CSR	Status			
130	Replace front hub seals and left side locking 4X4 hub (Auto 4X4 inop, left locking hub siezing)	7	SHAYNA	Approved			
Labour	Description	Type	Amount				
130	Replace front hub seals and left side locking 4X4 hub (Auto 4X4 inop, left locking hub siezing)	CD	1,462.50				
Part	Description	Shp	Bin	Type	Retail	Price	Amount
BC3Z 3B396 A	LINK ASY - FRONT AXLE	1	E2	CR16	288.29	288.29	288.29
STK							
5C3Z 3254 C	SEAL ASY	2	E2	CR16	165.55	165.55	331.10
EC3Z 3254 A	SEAL ASY - OIL	2	E1D	CR16	60.06	60.06	120.12
STK							
BRS 170	SEAL	2	B1D	CR16	59.18	59.18	118.36
STK							
BC3Z 3B396 A	LINK ASY - FRONT AXLE	1	E2	CR16	288.29	288.29	288.29
STK							
5C3Z 2B513 AA	KIT - BALL BEARING	1	E1D	CR16	122.96	122.96	122.96
CXY 80W90 1L6	OIL - REAR AXLE	3	J2	CR16	12.60	12.60	37.80
ENOIL	ENVIRO FEE OIL	3	SPORD	CR16	0.10	0.10	0.30
CXY 75W140 1L6	OIL - REAR AXLE	1	J2	CR16	44.63	44.63	44.63
ENOIL	ENVIRO FEE OIL	1	SPORD	CR16	0.10	0.10	0.10
CXT 10 LV6	FLUID - TRANSMISSION	2	WH1	CR16	10.92	10.92	21.84
ENOIL	ENVIRO FEE OIL	2	SPORD	CR16	0.10	0.10	0.20
Technician	4 -				<b>Parts Total</b>		1,373.99
Cause	Inspect for auto 4X4 inop, test hub seals found them both leaking.				<b>Labour Total</b>		1,462.50

**TERMS: STRICTLY CASH UNLESS ARRANGEMENTS ARE MADE.** "I hereby authorize the repair work hereinafter to be done along with the necessary material and agree that you are not responsible for loss or damage to vehicle or articles left in the vehicle in case of fire, theft, or any other cause beyond your control or for any delays caused by unavailability of parts or delays in parts shipments by the supplier or transporter. I hereby grant you or your employees permission to operate the vehicle herein described on streets, highways, or elsewhere for the purpose of testing and/or inspection. An express mechanic's lien is hereby acknowledged on above vehicle to secure the amount of repairs thereto."

**DISCLAIMER OF WARRANTIES:** Any warranties on the products sold hereby are those made by the manufacturer. The seller hereby expressly disclaims all warranties either express or implied, including any implied warranty of merchantability or fitness for a particular purpose, and the seller neither assumes or authorizes any other person to assume for it any liability in connection with the sale of said products. Any limitation contained herein does not apply where prohibited by law.

**PRIVACY STATEMENT:** Personal information is collected in accordance with applicable privacy legislation and is governed by the Dealer's Privacy Policy. Your privacy is important to us. Ask us if you would like information about our Privacy Policy. We provide this personal information to Ford Motor Company of Canada Limited (together with third parties acting on its behalf "Ford") to enable Ford to administer your transaction, to provide you with services, to improve automotive related products and services by conducting customer surveys, and to provide you with marketing material which may be of interest to you. To obtain the Ford Privacy Policy or if you do not want to receive marketing or survey materials from Ford please call 1-800-565-FORD (3673).

**NO RETURN ON ELECTRICAL OR SAFETY ITEMS OR SPECIAL ORDERS**

**DISCLAIMER:** Wheel lug nuts must be retorqued 100km after any wheel has been removed. This is the CUSTOMERS responsibility.

Customer Signature: \_\_\_\_\_

GST# 10570 8457 RT0001

**WINDSOR FORD**

10001 139 Avenue • Grande Prairie, AB • T8X 0V3  
 Tel: (780) 532-9555 • 1-800-422-6094  
 service@windsorford.com • www.windsorford.com  
 SERVICE HOURS - Mon - Sat 7:15 a.m. - 6:00 p.m.

**GENUINE PEOPLE  
 TREATING YOU LIKE  
 A PERSON**

**OUR REPUTATION IS  
 YOUR EXPERIENCE**

**SO# 564131**

## SERVICE ORDER CUSTOMER COPY



Printed 01/24/2024 10:26:40 AM

User 1264 Page 5

<b>Customer No</b>		<b>Advisor</b> Shayna D	<b>Promised</b> 10/25/2023 6:30 PM	2721
CARIBOO RAILROAD CONTRACTING CORP. 3030 PANDOSY Unit #117 KELOWNA, BC V1Y 0C4		<b>Shop</b> WF	<b>Opened</b> 10/20/2023 4:57 PM	<b>Location</b>
<b>Home</b>		<b>Priority</b>	<b>Cashiered</b> 11/24/2023 4:44 PM	<b>PO #</b> AB.UNIT55.GP
<b>Cell</b>	<b>Bus</b> (778) 478-1745 <b>Today</b>	<b>License</b>	<b>Odom In</b>	<b>Odom Out</b>
<b>Email</b>		739LLQ	194792	194792
<b>Term</b> CHARGE		<b>Year</b> 2019	<b>Make</b> FORD	<b>Model</b> SUPER DUTY F-550 DRW W5H
		<b>Vehicle ID No</b>	<b>Selling Dealer</b>	<b>Extended Warranty</b>
		1FD0W5HT4KEE14684		
		<b>Engine</b> 6.7L 4V OHV POWER STROKE V8		<b>Stock No</b> 55
				<b>Colour</b> OXFORD
				<b>Delivery Date</b>

Correction Remove both front wheel bearing assys, remove both front axle shafts, found inner diff seals leaking. Remove carrier assy, install new inner diff seals. Clean tubes of oil and mud. Install front axle shafts with new hub seals and both new locking hubs (both locking hubs broke apart during removal). Retest operation, good at this time

**Request Sub-total 2,836.49**

**Job Code:** ab.cn.un55.hr  
**Task Code:** a16  
**Equipment Unit #:** 55  
**Comment:** repairs

Rec Jan 24/23

DocuSigned by:  
  
 FEC3DE5E49404D9...  
 2024-01-25

Labour 4,856.19  
 Parts 6,263.18  
 Supplies 75.00  
 Env Fee 5.00  
**Sub-Total 11,199.37**  
 GST 0.00  
 Third Party GST 559.97  
**Total Invoice 11,759.34**

Customer Deductible 0.00  
 GST 0.00  
**Customer Total 0.00**

**Third Party Billable 11,759.34**  
 CARIBOO RAILROAD  
 CONTRACTING CORP. -  
 CARIBOO CENTR1

**TERMS: STRICTLY CASH UNLESS ARRANGEMENTS ARE MADE.** "I hereby authorize the repair work hereinafter to be done along with the necessary material and agree that you are not responsible for loss or damage to vehicle or articles left in the vehicle in case of fire, theft, or any other cause beyond your control or for any delays caused by unavailability of parts or delays in parts shipments by the supplier or transporter. I hereby grant you or your employees permission to operate the vehicle herein described on streets, highways, or elsewhere for the purpose of testing and/or inspection. An express mechanic's lien is hereby acknowledged on above vehicle to secure the amount of repairs thereto."

**DISCLAIMER OF WARRANTIES:** Any warranties on the products sold hereby are those made by the manufacturer. The seller hereby expressly disclaims all warranties either express or implied, including any implied warranty of merchantability or fitness for a particular purpose, and the seller neither assumes or authorizes any other person to assume for it any liability in connection with the sale of said products. Any limitation contained herein does not apply where prohibited by law.

**PRIVACY STATEMENT:** Personal information is collected in accordance with applicable privacy legislation and is governed by the Dealer's Privacy Policy. Your privacy is important to us. Ask us if you would like information about our Privacy Policy. We provide this personal information to Ford Motor Company of Canada Limited (together with third parties acting on its behalf "Ford") to enable Ford to administer your transaction, to provide you with services, to improve automotive related products and services by conducting customer surveys, and to provide you with marketing material which may be of interest to you. To obtain the Ford Privacy Policy or if you do not want to receive marketing or survey materials from Ford please call 1-800-565-FORD (3673).

NO RETURN ON ELECTRICAL OR SAFETY ITEMS OR SPECIAL ORDERS

DISCLAIMER: Wheel lug nuts must be retorqued 100km after any wheel has been removed. This is the CUSTOMERS responsibility.

Customer Signature: \_\_\_\_\_

GST# 10570 8457 RT0001

# CORNER GARAGE

Box 55  
 Barwick, Ontario P0W 1A0  
 Canada  
 dave.cornergarage@gmail.com

# INVOICE

Invoice No.: 751912  
 Date: 09/21/2022  
 Ship Date:  
 Page: 1  
 Re: Order No.

**Sold to:**  
 Caribou Central Rail  
 6565 Industrial Way  
 Prince George, BC V2N 5S6

**Ship to:**  
 2019 Ford F550  
 Unit 55  
 141,907 KM

HST # 849548508 RT0001

Item No.	Quantity	Description	Tax	Unit Price	Amount
LAB150	3.25	Run out to Sleepy Owl. Batteries dead in truck - nothing appeared to be left on. Boosted and checked charging operation - charging excellent. Original batteries had signs of being cooked. Ran got batteries and changed.	HST	150.00	487.50
	2.00	Battery	HST	170.96	341.92
		Subtotal:			829.42
		HST - HST 13%			107.83
		HST			
<b>Job Code:</b>	ON . CN . UN55 . HR				
<b>Task Code:</b>	A16NB				
<b>Equipment Unit #:</b>	55				
<b>Comment:</b>	BATTERIES				
		Rec Sep 22/22			
CORNER GARAGE	HST: #HST 13%				

DocuSigned by:  
  
 275231AF148B49C...  
 Sep 27, 2022

Shipped By:	Tracking Number:	<b>Total Amount</b>	937.25
<b>Comment:</b>	Clients assume liability for vehicles & contents while parked on premises. Retorque wheels in 100 km	<b>Amount Paid</b>	937.25
<b>Sold By:</b>		<b>Amount Owng</b>	0.00



**T&B Fleet Services**  
 #2 877 Redonda St.  
 Sunnyside, MB. R5R 0J4  
 Phone: 204-222-3608  
 Fleet Hrail Repairs & Vehicle Service

**INVOICE**

1911

Org. Est. # 001325  
 GST #77259 9601 RT0001

**INVOICE**

Printed Date: 07/25/2022

Work Completed: 07/25/2022

**Cariboo Central Railroad**  
 101 Cory Road  
 Saskatoon, SK S7K 3J7

2019 Ford - F-550 Super Duty XLT - 6.7L, V8 (406CI) VIN(T)  
 Lic # : Odometer In : 130242  
 Unit # : 55  
 VIN # : 1FD0W5HT4 KEE14684

Part Description	Number	Qty	Sale	Ext	Labor Description	Hours	Ext
Shop Supplies				3.75	rear hirail locks wont move found some one welded on extension to the lock pins by 2 inches, thus could not be pulled away far enough to release the hirail, removed lock pins cut off extensions, smooth out pins again, adjust rear hirail lock to work as was designed,	1.20	150.00
Taxes							
GST							7.69
PST							10.76

Org. Estimate 172.20 Revisions 0.00 Current Estimate 172.20

Job Code: CARIBOO.OPS23

Task Code: A99

Equipment Unit #: 55

Comment: HI-RAIL

DocuSigned by:  
  
 275231AF148B49C...  
 Jul 26, 2022

Labor:	150.00
Parts:	3.75
SubTotal:	153.75
Tax:	18.45
Total:	172.20
Bal Due:	\$172.20

[ Payments - ]  
 Rec Jul 25/22

**THANKS FOR YOUR BUSINESS!**

Vehicle Received: 7/25/2022

Customer Number : 65

Wheel Nuts are torqued to factory specifications & must be rechecked within 100 KMS from time wheels were removed. T&B Fleet Services is not responsible for loss or damage to vehicles or articles left in vehicle in case of fire, theft, or any other cause beyond our control.  
 Parts Warranty is set by the manufacturer, typically 1 year. Labor Warranty is 90 days and must be performed in our shop and cannot exceed the original cost of repairs.  
 PAYMENT TERMS: Net 30 NOTE: If paying by credit card over the phone there will be a 3% charge to total invoice

Signature \_\_\_\_\_ Date \_\_\_\_\_

CUSTOMER #:  
UNIT# 157912

600156



**TEAM FORD**

DRIVING FORCE LEDUC  
8336 SPARROW CRESCENT  
LEDUC, AB T9E 8B7  
HOME:780-930-3659 CONT:780-930-3659  
BUS: CELL:

INVOICE

3304 - 91st Street, Edmonton, AB T6N 1C1  
Tel: 780-462-8300 Fax: 780-461-0055  
www.teamford.ca

PAGE 1

SERVICE ADVISOR: 410 ROBERT KRAUSE

COLOUR	YEAR	MAKE/MODEL	VIN	LICENSE	ODOMETER IN/ OUT	TAG	
WHITE	19	FORD F550	1FD0W5HT4KEE14684	UNIT55	116425/118362	T2910	
DEL DATE	PROD. DATE	WARR. EXP.	PROMISED	PO NO.	RATE	PAYMENT	INV. DATE
25FEB19 DD			17:00 14MAR22	UNIT55	110.00	CHG	29MAR22
R.O. OPENED	READY	OPTIONS: DLR:B6210 ENG:6.7_Liter					
08:42 23FEB22	07:45 29MAR22						

LINE	OPCODE	TECH	TYPE	HOURS	LIST	NET	TOTAL
------	--------	------	------	-------	------	-----	-------

A HIGH RAIL INSPECTION  
CAUSE: CUST. REQUEST  
HRI HIGH RAIL INSPECTION  
1591 CPT 2.00 240.00 240.00  
PARTS: 0.00 LABOR: 240.00 OTHER: 0.00 TOTAL LINE A: 240.00  
HIGH RAIL INSPECTION COMPLETED. ESTIMATE OF SUGGESTED REPAIRS PROVIDED

\*\*\*\*\*

B SEND TO XTREME FOR GPS INSTALLATION  
57 SUBLET REPAIRS  
999 CPT 0.00 0.00 0.00  
1 \*INSTALL\* 110.00 110.00 110.00  
PARTS: 110.00 LABOR: 0.00 OTHER: 0.00 TOTAL LINE B: 110.00

\*\*\*\*\*

C\*\* 54 POINT INSPECTION54 POINT / QC 550  
CAUSE: CUST. REQUEST  
1203 54 POINT INSPECTION54 POINT / QC 550  
1591 CPT 1.00 69.95 69.95  
PARTS: 0.00 LABOR: 69.95 OTHER: 0.00 TOTAL LINE C: 69.95  
54 POINT INSPECTION COMPLETE. ESTIMATE OF SUGGESTED REPAIRS PROVIDED. WHEELS TORQUED TO 165FT/LBS. TIRE PRESSURES SET TOI 95PSI FRONT & 110PSI REAR.

\*\*\*\*\*

D\*\* REPLACE WIPER BLADES N/C LABOUR  
CAUSE: STREAKING  
153 REPLACE WIPER BLADES N/C LABOUR  
1591 CPT 0.00 0.00 0.00  
2 WW\*2202\*PF BLADE ASY - WIPER 21.22 15.28 30.56  
PARTS: 30.56 LABOR: 0.00 OTHER: 0.00 TOTAL LINE D: 30.56  
REPLACED STREAKING WIPER BLADES

\*\*\*\*\*

E\*\* REPLACE LICENSE PLATE LIGHT  
CAUSE: BURNT OUT  
152 BULBS ( EXTRA TIME MAY BE REQUIRED DEPENDING

**STATEMENT OF DISCLAIMER**

The factory warranty constitutes all of the warranties with respect to the sale of this item/items. The Seller hereby expressly disclaims all warranties either express or implied, including any implied warranty of merchantability or fitness for a particular purpose. Seller neither assumes nor authorizes any other person to assume for it any liability in connection with the sale of this item/items.

I agree to receive E-mails, texts and other electronic communications containing promotions, news updates and other promotional material regarding Go Auto's and Go Insurance's products and services.

DESCRIPTION	TOTALS
LABOUR AMOUNT	
PARTS AMOUNT	
GAS, OIL, LUBE	
SUBLET AMOUNT	
MISC. CHARGES	
TOTAL CHARGES	
LESS INSURANCE	
SALES TAX	
<b>PLEASE PAY THIS AMOUNT</b>	

CUSTOMER SIGNATURE

DATE

CUSTOMER #:  
UNIT# 157912

600156



**TEAM FORD**

DRIVING FORCE LEDUC  
8336 SPARROW CRESCENT  
LEDUC, AB T9E 8B7  
HOME:780-930-3659 CONT:780-930-3659  
BUS: CELL:

INVOICE

3304 - 91st Street, Edmonton, AB T6N 1C1  
Tel: 780-462-8300 Fax: 780-461-0055  
www.teamford.ca

PAGE 2

SERVICE ADVISOR: 410 ROBERT KRAUSE

COLOUR	YEAR	MAKE/MODEL	VIN	LICENSE	ODOMETER IN/ OUT	TAG	
WHITE	19	FORD F550	1FD0W5HT4KEE14684	UNIT55	116425/118362	T2910	
DEL DATE	PROD. DATE	WARR. EXP.	PROMISED	PO NO.	RATE	PAYMENT	INV. DATE
25FEB19 DD			17:00 14MAR22	UNIT55	110.00	CHG	29MAR22
R.O. OPENED	READY	OPTIONS: DLR:B6210 ENG:6.7_Liter					
08:42 23FEB22	07:45 29MAR22						

LINE	OPCODE	TECH	TYPE	HOURS	LIST	NET	TOTAL
ON VEHICLE)							
				1591 CPT	0.40	48.00	48.00
1	60661	LP	LAMP		21.74	21.74	21.74
1	60291	LAMP			8.58	8.58	8.58
1	G3002EA	2"	RED LED		18.50	11.65	11.65
PARTS:	41.97	LABOR:	48.00	OTHER:	0.00	TOTAL LINE E:	89.97
REPLACED LICENCE PLATE LIGHT ASSEMBLY & WIRED IN. CHECKED OPERATION - GOOD.							

\*\*\*\*\*

F\*\* REPAIR WIRING FOR RIGHT REAR FLOOD LIGHT  
CAUSE: BROKEN WIRING

900 ELECTRICAL / GAS DRIVABILITY

	1591 CPT	0.50				60.00	60.00
PARTS:	0.00	LABOR:	60.00	OTHER:	0.00	TOTAL LINE F:	60.00
REPAIRED WIRING FOR R/F FLOOD LIGHT & TESTED OPERATION - GOOD.							

\*\*\*\*\*

G\*\* MAINT #1 - DIESEL - OIL & FILTER CHANGE, MULTI-POINT INSPECTION  
CAUSE: MAINT./DISTANCE

1D MAINT #1 - DIESEL - OIL & FILTER CHANGE,  
MULTI-POINT INSPECTION

	1591 CPT	0.80				65.00	65.00
1	FL*2051*S	KIT - ELEMENT & GASK			41.13	27.14	27.14
1	OILFL	OIL FILTER ENVIRONMENTAL FEE			0.50	0.50	0.50
13	CXO*10W30*DSP	DIESEL OIL			6.20	4.14	53.82
13	OIL	OIL ENVIRONMENTAL FEE			0.10	0.10	1.30
1	FD*4625*AA	ELEMENT			141.82	93.60	93.60
1	OILFL2	OIL FILTER 12 ENVIRONMENTAL FEE					
					1.00	1.00	1.00
PARTS:	174.56	LABOR:	65.00	OTHER:	2.80	TOTAL LINE G:	242.36
LUBE, OIL & FILTER COMPLETED. TIRE PRESSURES SET TO 95PSI FRONT & 110PSI REAR							

\*\*\*\*\*

H\*\* REPLACE ALL 4 BALL JOINTS  
CAUSE: EXCESSIVE WEAR

**STATEMENT OF DISCLAIMER**

The factory warranty constitutes all of the warranties with respect to the sale of this item/items. The Seller hereby expressly disclaims all warranties either express or implied, including any implied warranty of merchantability or fitness for a particular purpose. Seller neither assumes nor authorizes any other person to assume for it any liability in connection with the sale of this item/items.

I agree to receive E-mails, texts and other electronic communications containing promotions, news updates and other promotional material regarding Go Auto's and Go Insurance's products and services.

STATEMENT OF DISCLAIMER	DESCRIPTION	TOTALS
CUSTOMER SIGNATURE _____ DATE _____	LABOUR AMOUNT	
	PARTS AMOUNT	
	GAS, OIL, LUBE	
	SUBLET AMOUNT	
	MISC. CHARGES	
	TOTAL CHARGES	
	LESS INSURANCE	
	SALES TAX	
	<b>PLEASE PAY THIS AMOUNT</b>	

CUSTOMER #:  
UNIT# 157912

600156



**TEAM FORD**

DRIVING FORCE LEDUC  
8336 SPARROW CRESCENT  
LEDUC, AB T9E 8B7  
HOME:780-930-3659 CONT:780-930-3659  
BUS: CELL:

INVOICE

3304 - 91st Street, Edmonton, AB T6N 1C1  
Tel: 780-462-8300 Fax: 780-461-0055  
www.teamford.ca

PAGE 3

SERVICE ADVISOR: 410 ROBERT KRAUSE

COLOUR	YEAR	MAKE/MODEL	VIN	LICENSE	ODOMETER IN/ OUT	TAG	
WHITE	19	FORD F550	1FD0W5HT4KEE14684	UNIT55	116425/118362	T2910	
DEL DATE	PROD. DATE	WARR. EXP.	PROMISED	PONO.	RATE	PAYMENT	INV. DATE
25FEB19 DD			17:00 14MAR22	UNIT55	110.00	CHG	29MAR22
R.O. OPENED		READY		OPTIONS:			
08:42 23FEB22		07:45 29MAR22		DLR:B6210 ENG:6.7_Liter			

LINE	OPCODE	TECH	TYPE	HOURS	LIST	NET	TOTAL				
303 BALL JOINTS											
				1591 CPT 7.30		876.00	876.00				
				2 MCF*2413* JOINT ASY - BALL	112.91	74.52	149.04				
				2 F2TZ*3A049*A NUT - CASTLE	11.72	8.44	16.88				
				2 MCF*2400* JOINT ASY - BALL	149.29	98.53	197.06				
				2 F2TZ*3A050*A NUT - WORM DRIVE	11.57	8.33	16.66				
				1 *W711373*S440 NUT	4.80	2.88	2.88				
				1 *W711374*S439 RETAINER - NUT	3.43	2.05	2.05				
				2 BRS*170* SEAL	42.33	27.94	55.88				
				2 5C3Z*3254*C SEAL ASY - OIL	125.53	90.38	180.76				
PARTS:				621.21	LABOR:	876.00	OTHER:	0.00	TOTAL LINE H:	1497.21	
REPLACED ALL 4 WORN BALL JOINTS, ALL NEW AXLE HUB SEALS ETC. USED ON ASSEMBLY. SENT TO ALIGNMENT AFTER COMPLETED.											
*****											
I** REPLACE TRACK BAR BALL JOINT											
CAUSE: EXCESSIVE PLAY											
306A TRACK BAR BALL JOINT											
				1591 CPT 1.00		120.00	120.00				
				1 MS40522 JOINT ASY	69.95	69.95	69.95				
PARTS:				69.95	LABOR:	120.00	OTHER:	0.00	TOTAL LINE I:	189.95	
REPLACED EXCESSIVELY WORN TRACK BAR BALL JOINT											
*****											
J** REPLACE TRACK BAR BUSHING											
CAUSE: BUSHING TORN											
306 TRACK BAR											
				1591 CPT 1.00		120.00	120.00				
				1 AC3Z*3A116*A BUSH - FRONT SUSPENS	28.38	20.44	20.44				
PARTS:				20.44	LABOR:	120.00	OTHER:	0.00	TOTAL LINE J:	140.44	
REPLACED TORN TRACK BAR BUSHING											
*****											
K** REPLACE LEFT OUTER TIE ROD END											
CAUSE: EXCESSIVE WEAR/PLAY											
304 TIE ROD END(S)											
				1591 CPT 1.50		120.00	120.00				

**STATEMENT OF DISCLAIMER**

The factory warranty constitutes all of the warranties with respect to the sale of this item/items. The Seller hereby expressly disclaims all warranties either express or implied, including any implied warranty of merchantability or fitness for a particular purpose. Seller neither assumes nor authorizes any other person to assume for it any liability in connection with the sale of this item/items.

I agree to receive E-mails, texts and other electronic communications containing promotions, news updates and other promotional material regarding Go Auto's and Go Insurance's products and services.

DESCRIPTION	TOTALS
LABOUR AMOUNT	
PARTS AMOUNT	
GAS, OIL, LUBE	
SUBLET AMOUNT	
MISC. CHARGES	
TOTAL CHARGES	
LESS INSURANCE	
SALES TAX	
<b>PLEASE PAY THIS AMOUNT</b>	

CUSTOMER SIGNATURE

DATE

CUSTOMER #:  
UNIT# 157912

600156



**TEAM FORD**

DRIVING FORCE LEDUC  
8336 SPARROW CRESCENT  
LEDUC, AB T9E 8B7  
HOME:780-930-3659 CONT:780-930-3659  
BUS: CELL:

INVOICE

3304 - 91st Street, Edmonton, AB T6N 1C1  
Tel: 780-462-8300 Fax: 780-461-0055  
www.teamford.ca

PAGE 4

SERVICE ADVISOR: 410 ROBERT KRAUSE

COLOUR	YEAR	MAKE/MODEL	VIN	LICENSE	ODOMETER IN/ OUT	TAG	
WHITE	19	FORD F550	1FD0W5HT4KEE14684	UNIT55	116425/118362	T2910	
DEL DATE	PROD. DATE	WARR. EXP.	PROMISED	PO NO.	RATE	PAYMENT	INV. DATE
25FEB19 DD			17:00 14MAR22	UNIT55	110.00	CHG	29MAR22
R.O. OPENED	READY	OPTIONS: DLR:B6210 ENG:6.7_Liter					
08:42 23FEB22	07:45 29MAR22						

LINE	OPCODE	TECH	TYPE	HOURS	LIST	NET	TOTAL
1	*W711373	*S440	NUT		4.80	2.88	2.88
1	*W711374	*S439	RETAINER - NUT		3.43	2.05	2.05
1	MEF*359	*END	- SPINDLE ROD CO		300.29	198.19	198.19
PARTS: 203.12 LABOR: 120.00 OTHER: 0.00 TOTAL LINE K:							323.12
REPLACED EXCESSIVELY WORN LEFT & RIGHT OUTER TIE ROD ENDS.							

L\*\* 4 WHEEL ALIGNMENT

350 4 WHEEL ALIGNMENT							
126 CPT	1.40					149.95	149.95
PARTS: 0.00 LABOR: 149.95 OTHER: 0.00 TOTAL LINE L:							149.95

PERFORMED WHEEL ALIGNMENT AS PER INSTRUCTIONS.

M\*\* CHECK AND ADVISE FOR OIL LEAK COMING FROM BELL HOUSING AREA  
CAUSE: TORQUE SEAL  
ADD ADDED OPERATION FOR SAFETY OR DRIVABILITY CONCERN

1591 WT	0.00						(N/C)
7000A AUTOMATIC TRANSMISSION ASSEMBLY - REMOVE AND INSTALL OR REPLACE (7000) - L							
1591 WT	7.40						(N/C)
7000AZJ AUTOMATIC TRANSMISSION ASSEMBLY - REMOVE AND INSTALL OR REPLACE (7000) - L EXTRA TIME TO MOUNT TRANSMISSION ON A							
1591 WT	0.40						(N/C)
7000A7 AUTOMATIC TRANSMISSION SEAL - FRONT PUMP TO CONVERTER - REPLACE (7A248/7F401) - L							
1591 WT	0.40						(N/C)
MT7000 EXTRA TIME FOR PTO ACCESS							
1591 WT	2.00						(N/C)
7000E AUTOMATIC TRANSMISSION - EXTERNAL OIL LEAKS -DIAGNOSIS (7000) - L							
1591 WT	0.90						(N/C)
1 BC3Z*7A248*A SEAL ASY - OIL							(N/C)
6 *W715618*S437 NUT							(N/C)

STATEMENT OF DISCLAIMER		DESCRIPTION	TOTALS
The factory warranty constitutes all of the warranties with respect to the sale of this item/items. The Seller hereby expressly disclaims all warranties either express or implied, including any implied warranty of merchantability or fitness for a particular purpose. Seller neither assumes nor authorizes any other person to assume for it any liability in connection with the sale of this item/items. <input type="checkbox"/> I agree to receive E-mails, texts and other electronic communications containing promotions, news updates and other promotional material regarding Go Auto's and Go Insurance's products and services.		LABOUR AMOUNT	
		PARTS AMOUNT	
		GAS, OIL, LUBE	
		SUBLET AMOUNT	
		MISC. CHARGES	
		TOTAL CHARGES	
		LESS INSURANCE	
		SALES TAX	
CUSTOMER SIGNATURE	DATE	<b>PLEASE PAY THIS AMOUNT</b>	

CUSTOMER #:  
UNIT# 157912

600156



**TEAM FORD**

DRIVING FORCE LEDUC  
8336 SPARROW CRESCENT  
LEDUC, AB T9E 8B7  
HOME:780-930-3659 CONT:780-930-3659  
BUS: CELL:

INVOICE

3304 - 91st Street, Edmonton, AB T6N 1C1  
Tel: 780-462-8300 Fax: 780-461-0055  
www.teamford.ca

PAGE 5

SERVICE ADVISOR: 410 ROBERT KRAUSE

COLOUR	YEAR	MAKE/MODEL	VIN	LICENSE	ODOMETER IN/ OUT	TAG	
WHITE	19	FORD F550	1FD0W5HT4KEE14684	UNIT55	116425/118362	T2910	
DEL DATE	PROD. DATE	WARR. EXP.	PROMISED	PO NO.	RATE	PAYMENT	INV. DATE
25FEB19 DD			17:00 14MAR22	UNIT55	110.00	CHG	29MAR22
R.O. OPENED		READY		OPTIONS: DLR:B6210 ENG:6.7_Liter			
08:42 23FEB22	07:45 29MAR22						

LINE	OPCODE	TECH	TYPE	HOURS	LIST	NET	TOTAL
4	*	W710356	*S439 BOLT				(N/C)
4	*	W520515	*S440 NUT				(N/C)
2	*	W709771	*S440 NUT - ADJUSTING SCRE				(N/C)
2	E4HZ	*4A254	*B RETAINER				(N/C)
4	E4HZ	*4A254	*A RETAINER				(N/C)
8	F1HZ	*4N272	*A BOLT				(N/C)
4	F81Z	*4N272	*AA BOLT - HEX.HEAD				(N/C)
5	CXT	*10	*LVB TRANSMISSION FLUID				(N/C)
5	OIL	OIL	ENVIRONMENTAL FEE				(N/C)
1	OIL	*DYE	* OIL DYE				(N/C)

FC: PART#: COUNT:  
CLAIM TYPE:  
AUTH CODE:  
1591

PARTS: 0.00 LABOR: 0.00 OTHER: 0.00 TOTAL LINE M: 0.00

WASHED OFF & ADDED DYE TO TRANSMISSION. ROAD TESTED & LIFTED TRUCK ON HOIST. FOUND OIL COMING FROM BELL HOUSING AREA. REMOVED TRANSMISSION & FOUND TORQUE CONVERTOR SEAL LEAKING. PLACED TRANS IN BENCH FIXTURE & REMOVED TORQUE CONVERTOR. REPLACED TORQUE CONVERTOR SEAL & RE-INSTALLED CONVERTOR. INSTALLED TRANS BACK INTO TRUCK. ADDED FLUID, STARTED & RAN TO TEMP. ROAD TESTED & RECHECKED TO VERIFY REPAIR - GOOD. TOPPED FLUID LEVEL. \*\* NOTE \*\* TRUCK IS TRANS DRIVEN PTO EQUIPPED-MT EXTRA TIME REQUIRED.

\*\*\*\*\*

N\*\* CHECK AND ADVISE FOR OIL LEAK COMING FROM BACK OF ENGINE AREA  
CAUSE: NONE

NFF NO FAULT FOUND. UNABLE TO DUPLICATE CONCERN  
AT THIS TIME. RECOMMEND POSSIBLE ROADTEST  
WITH SHOP FOREMAN

1591 CPT 0.00 0.00 0.00

PARTS: 0.00 LABOR: 0.00 OTHER: 0.00 TOTAL LINE N: 0.00

INSPECTED FOR REAR MAIN SEAL, OR REAR COVER LEAK WHILE TRANS OUT.  
FOUND NO ENGINE OIL LEAK.

\*\*\*\*\*

**STATEMENT OF DISCLAIMER**

The factory warranty constitutes all of the warranties with respect to the sale of this item/items. The Seller hereby expressly disclaims all warranties either express or implied, including any implied warranty of merchantability or fitness for a particular purpose. Seller neither assumes nor authorizes any other person to assume for it any liability in connection with the sale of this item/items.

I agree to receive E-mails, texts and other electronic communications containing promotions, news updates and other promotional material regarding Go Auto's and Go Insurance's products and services.

DESCRIPTION	TOTALS
LABOUR AMOUNT	
PARTS AMOUNT	
GAS, OIL, LUBE	
SUBLET AMOUNT	
MISC. CHARGES	
TOTAL CHARGES	
LESS INSURANCE	
SALES TAX	
<b>PLEASE PAY THIS AMOUNT</b>	

CUSTOMER SIGNATURE \_\_\_\_\_ DATE \_\_\_\_\_

CUSTOMER #:  
UNIT# 157912

600156



**TEAM FORD**

INVOICE

DRIVING FORCE LEDUC  
8336 SPARROW CRESCENT  
LEDUC, AB T9E 8B7  
HOME:780-930-3659 CONT:780-930-3659  
BUS: CELL:

3304 - 91st Street, Edmonton, AB T6N 1C1  
Tel: 780-462-8300 Fax: 780-461-0055  
www.teamford.ca

PAGE 6

SERVICE ADVISOR: 410 ROBERT KRAUSE

COLOUR	YEAR	MAKE/MODEL	VIN	LICENSE	ODOMETER IN/ OUT	TAG	
WHITE	19	FORD F550	1FD0W5HT4KEE14684	UNIT55	116425/118362	T2910	
DEL DATE	PROD. DATE	WARR. EXP.	PROMISED	PO NO.	RATE	PAYMENT	INV. DATE
25FEB19 DD			17:00 14MAR22	UNIT55	110.00	CHG	29MAR22
R.O. OPENED	READY	OPTIONS: DLR:B6210 ENG:6.7_Liter					
08:42 23FEB22	07:45 29MAR22						

LINE	OPCODE	TECH	TYPE	HOURS	LIST	NET	TOTAL
------	--------	------	------	-------	------	-----	-------

O\*\* REAR DIFFERENTIAL SERVICE  
CAUSE: DARK, LOW LEVEL  
206 REAR DIFFERENTIAL SERVICE  
1591 CPT 1.00 120.00 120.00  
5 CXY\*75W140\*1L6 OIL - REAR AXLE 32.49 23.00 115.00  
5 OIL OIL ENVIRONMENTAL FEE 0.10 0.10 0.50  
1 TA\*357\* SEALANT - SILICONE 61.13 40.34 40.34  
PARTS: 155.34 LABOR: 120.00 OTHER: 0.50 TOTAL LINE O: 275.84  
DRAINED REAR DIFF FLUID. CLEANED & FILLED WITH NEW FLUID TO PROPER LEVEL

P\*\* TRANSFER CASE SERVICE  
CAUSE: FLUID DARK & LOW LEVEL  
208 TRANSFER CASE SERVICE  
1591 CPT 0.50 55.00 55.00  
3 CXT\*10\*LV6 ADDITIVE - OIL - FRI 8.87 6.38 19.14  
3 OIL OIL ENVIRONMENTAL FEE 0.10 0.10 0.30  
PARTS: 19.14 LABOR: 55.00 OTHER: 0.30 TOTAL LINE P: 74.44  
DRAINED TRANSFER CASE & FLUSHED/CLEANED. FILLED TO PROPER LEVEL.

Q\*\* TRANSMISSION FLUSH  
CAUSE: FLUID VERY DARK IN COLOR  
203 TRANSMISSION FLUSH  
1591 CPT 1.00 110.00 110.00  
1 \*K6600\* SYN TRANS FLUS 15L 46.00 46.00 46.00  
1 \*BG\*3144 UNIV ATC CUBE 225.00 225.00 225.00  
1 OIL OIL ENVIRONMENTAL FEE 0.10 0.10 0.10  
PARTS: 271.00 LABOR: 110.00 OTHER: 0.10 TOTAL LINE Q: 381.10  
TRANS FLUSH COMPLETED. ADJUSTED LEVEL

R\*\* POWER STEERING FLUSH  
CAUSE: FLUID BURT/DIRTY  
201 POWER STEERING FLUSH  
1591 CPT 0.80 96.00 96.00

STATEMENT OF DISCLAIMER		DESCRIPTION	TOTALS
The factory warranty constitutes all of the warranties with respect to the sale of this item/items. The Seller hereby expressly disclaims all warranties either express or implied, including any implied warranty of merchantability or fitness for a particular purpose. Seller neither assumes nor authorizes any other person to assume for it any liability in connection with the sale of this item/items. <input type="checkbox"/> I agree to receive E-mails, texts and other electronic communications containing promotions, news updates and other promotional material regarding Go Auto's and Go Insurance's products and services.		LABOUR AMOUNT	
		PARTS AMOUNT	
		GAS, OIL, LUBE	
		SUBLET AMOUNT	
		MISC. CHARGES	
		TOTAL CHARGES	
		LESS INSURANCE	
		SALES TAX	
CUSTOMER SIGNATURE	DATE	PLEASE PAY THIS AMOUNT	

CUSTOMER #:  
UNIT# 157912

600156



**TEAM FORD**

DRIVING FORCE LEDUC  
8336 SPARROW CRESCENT  
LEDUC, AB T9E 8B7  
HOME:780-930-3659 CONT:780-930-3659  
BUS: CELL:

INVOICE

3304 - 91st Street, Edmonton, AB T6N 1C1  
Tel: 780-462-8300 Fax: 780-461-0055  
www.teamford.ca

PAGE 7

SERVICE ADVISOR: 410 ROBERT KRAUSE

COLOUR	YEAR	MAKE/MODEL	VIN	LICENSE	ODOMETER IN/ OUT	TAG	
WHITE	19	FORD F550	1FD0W5HT4KEE14684	UNIT55	116425/118362	T2910	
DEL DATE	PROD. DATE	WARR. EXP.	PROMISED	PO NO.	RATE	PAYMENT	INV. DATE
25FEB19 DD			17:00 14MAR22	UNIT55	110.00	CHG	29MAR22
R.O. OPENED	READY	OPTIONS: DLR:B6210 ENG:6.7 Liter					
08:42 23FEB22	07:45 29MAR22						

LINE	OPCODE	TECH	TYPE	HOURS	LIST	NET	TOTAL
1	K6700R	POWER STEERING FLUSH			60.00	60.00	60.00
PARTS: 60.00 LABOR: 96.00 OTHER: 0.00					TOTAL LINE R:		156.00
POWER STEERING FLUSH COMPLETED. ADJUSTED LEVEL							

\*\*\*\*\*  
**S\*\* REPLACE REAR BRAKE PADS & REPLACE ROTORS**  
 CAUSE: 4MM REMAINING  
 406 REPLACE REAR BRAKE PADS & REPLACE ROTORS  
 1591 CPT 5.00 600.00 600.00  
 1 BRF\*1547\* PAD - BRAKE 280.45 185.10 185.10  
 2 BRRF\*304\* ROTOR ASY - BRAKE 395.38 260.95 521.90  
 2 BRS\*190\* SEAL 71.47 47.17 94.34  
 PARTS: 801.34 LABOR: 600.00 OTHER: 0.00 TOTAL LINE S: 1401.34  
 REMOVED REAR BRAKES & CALIPERS. REMOVED REAR HUBS. REPLACED HUB SEALS & ROTORS. ADJUSTED E-BRAKE SHOES. ASSEMBLED ALL & REPLACED WORN REAR BRAKE PADS. CLEANED & LUBED ALL SLIDE PINS & GUIDES. WHEELS TORQUED TO 165 FT/LBS  
 \*\*\*\*\*

**T\*\* REPLACE FRONT GEAR BELLOWS**  
 CAUSE: TORN  
 HRR HIGH RAIL REPAIRS  
 1591 CPT 2.50 300.00 300.00  
 4 R-3591 FRONT BELLOWS 192.28 158.74 634.96  
 PARTS: 634.96 LABOR: 300.00 OTHER: 0.00 TOTAL LINE T: 934.96  
 DISASSEMBLED FRONT GEAR. REPLACED TORN GUIDE BELLOWS. CLEANED & LUBED RAIL GEAR GUIDES AT SAME TIME.  
 \*\*\*\*\*

**U\*\* REPLACE REAR BELLOWS AND JOUNCE BUMPERS**  
 CAUSE: TORN/DAMAGED  
 HRR HIGH RAIL REPAIRS  
 1591 CPT 5.00 600.00 600.00  
 4 R-3590 REAR BELLOWS 142.50 131.54 526.16  
 2 R-476A REAR JOUNCE 417.52 313.14 626.28  
 PARTS: 1152.44 LABOR: 600.00 OTHER: 0.00 TOTAL LINE U: 1752.44  
 DISASSEMBLED EAR GEAR, CLEANED SURFACES & REPLACED TORN BELLOWS.

STATEMENT OF DISCLAIMER		DESCRIPTION	TOTALS
The factory warranty constitutes all of the warranties with respect to the sale of this item/items. The Seller hereby expressly disclaims all warranties either express or implied, including any implied warranty of merchantability or fitness for a particular purpose. Seller neither assumes nor authorizes any other person to assume for it any liability in connection with the sale of this item/items. <input type="checkbox"/> I agree to receive E-mails, texts and other electronic communications containing promotions, news updates and other promotional material regarding Go Auto's and Go Insurance's products and services.		LABOUR AMOUNT	
		PARTS AMOUNT	
		GAS, OIL, LUBE	
		SUBLET AMOUNT	
		MISC. CHARGES	
		TOTAL CHARGES	
		LESS INSURANCE	
		SALES TAX	
CUSTOMER SIGNATURE	DATE	<b>PLEASE PAY THIS AMOUNT</b>	

CUSTOMER #:  
UNIT# 157912

600156



**TEAM FORD**

INVOICE

3304 - 91st Street, Edmonton, AB T6N 1C1  
Tel: 780-462-8300 Fax: 780-461-0055  
www.teamford.ca

DRIVING FORCE LEDUC  
8336 SPARROW CRESCENT  
LEDUC, AB T9E 8B7  
HOME:780-930-3659 CONT:780-930-3659  
BUS: CELL:

PAGE 8

SERVICE ADVISOR: 410 ROBERT KRAUSE

COLOUR	YEAR	MAKE/MODEL	VIN	LICENSE	ODOMETER IN/ OUT	TAG	
WHITE	19	FORD F550	1FD0W5HT4KEE14684	UNIT55	116425/118362	T2910	
DEL DATE	PROD. DATE	WARR. EXP.	PROMISED	PO NO.	RATE	PAYMENT	INV. DATE
25FEB19 DD			17:00 14MAR22	UNIT55	110.00	CHG	29MAR22
R.O. OPENED	READY	OPTIONS: DLR:B6210 ENG:6.7_Liter					
08:42 23FEB22	07:45 29MAR22						

LINE	OPCODE	TECH	TYPE	HOURS	LIST	NET	TOTAL
------	--------	------	------	-------	------	-----	-------

ALSO REPLACED JOUNCE BUMPERS WHILE APART. GREASED DURING ASSEMBLY.  
ASSEMBLED GEAR & TESTED OPERATION - GOOD

\*\*\*\*\*

V\*\* REPACK ALL RAIL WHEELS AND REPLACE SEALS  
CAUSE: EXCESS PLAY

HRR HIGH RAIL REPAIRS

1591 CPT 3.50 420.00 420.00  
4 24898 SEAL 16.95 6.30 25.20

PARTS: 25.20 LABOR: 420.00 OTHER: 0.00 TOTAL LINE V: 445.20

REMOVED ALL 4 RAIL WHEELS, CLEANED & REPACKED ALL BEARINGS &  
REPLACED WHEEL SEALS & INSTALLED.

\*\*\*\*\*

W\*\* REPLACE BRAKE PUMP  
CAUSE: DOES NOT PRODUCE PRESSURE

HRR HIGH RAIL REPAIRS

1591 CPT 1.50 180.00 180.00  
1 R-5670 PUMP 2850.00 1786.22 1786.22

PARTS: 1786.22 LABOR: 180.00 OTHER: 0.00 TOTAL LINE W: 1966.22

REPLACED INOP BRAKE PUMP. WIRED IN, FILLED WITH FLUID & TESTED  
OPERATION - GOOD

\*\*\*\*\*

X\*\* REPAIR BOTH FRONT SWEEP BRACKETS  
CAUSE: BENT/DAMAGED

HRR HIGH RAIL REPAIRS

1591 CPT 1.60 192.00 192.00  
2 R-2411 RUBBER SWEEP 40.76 37.62 75.24

2 F81Z\*1001\*BA RING - SEALING 4.69 3.10 6.20

1 \*BT2\* FLT BK PAINT 19.98 11.99 11.99

PARTS: 93.43 LABOR: 192.00 OTHER: 0.00 TOTAL LINE X: 285.43

REPAIRED BOTH FRONT SWEEP BRACKETS & REPLACED SWEEPS.

\*\*\*\*\*

Y\*\* HIGH RAIL ALIGNMENT

HRA HIGH RAIL ALIGNMENT

1591 CPT 2.50 300.00 300.00

**STATEMENT OF DISCLAIMER**

The factory warranty constitutes all of the warranties with respect to the sale of this item/items. The Seller hereby expressly disclaims all warranties either express or implied, including any implied warranty of merchantability or fitness for a particular purpose. Seller neither assumes nor authorizes any other person to assume for it any liability in connection with the sale of this item/items.

I agree to receive E-mails, texts and other electronic communications containing promotions, news updates and other promotional material regarding Go Auto's and Go Insurance's products and services.

DESCRIPTION	TOTALS
LABOUR AMOUNT	
PARTS AMOUNT	
GAS, OIL, LUBE	
SUBLET AMOUNT	
MISC. CHARGES	
TOTAL CHARGES	
LESS INSURANCE	
SALES TAX	
<b>PLEASE PAY THIS AMOUNT</b>	

CUSTOMER SIGNATURE DATE

CUSTOMER #:  
UNIT# 157912

600156

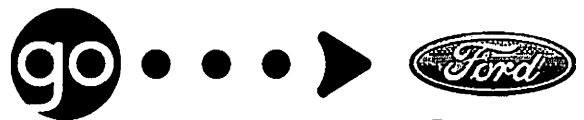

**TEAM FORD**

DRIVING FORCE LEDUC  
8336 SPARROW CRESCENT  
LEDUC, AB T9E 8B7  
HOME:780-930-3659 CONT:780-930-3659  
BUS: CELL:

INVOICE

3304 - 91st Street, Edmonton, AB T6N 1C1  
Tel: 780-462-8300 Fax: 780-461-0055  
www.teamford.ca

PAGE 9

SERVICE ADVISOR: 410 ROBERT KRAUSE

COLOUR	YEAR	MAKE/MODEL	VIN	LICENSE	ODOMETER IN/ OUT	TAG	
WHITE	19	FORD F550	1FD0W5HT4KEE14684	UNIT55	116425/118362	T2910	
DEL DATE	PROD. DATE	WARR. EXP.	PROMISED	PO NO.	RATE	PAYMENT	INV. DATE
25FEB19 DD			17:00 14MAR22	UNIT55	110.00	CHG	29MAR22

R.O. OPENED      READY      OPTIONS: DLR:B6210 ENG:6.7\_Liter

08:42 23FEB22      07:45 29MAR22

LINE	OPCODE	TECH	TYPE	HOURS	LIST	NET	TOTAL
PARTS:		0.00	LABOR:	300.00	OTHER:	0.00	TOTAL LINE Y: 300.00
HIGH RAIL ALIGNMENT COMPLETED. FILLED OUT INSPECTION/ALIGNMENT FORMS							

\*\*\*\*\*  
Z\*\* REPLACE REAR CONTROL COVER  
CAUSE: torn off/missing  
HRR HIGH RAIL REPAIRS  
1591 CPT 0.30      36.00      36.00  
PARTS: 0.00 LABOR: 36.00 OTHER: 0.00 TOTAL LINE Z: 36.00  
MADE & INSTALLED REAR GEAR CONTROLS COVER.

\*\*\*\*\*  
AA\*\*REPAIR AND ADJUST REAR GEAR LOCKS  
CAUSE: DAMAGED  
HRR HIGH RAIL REPAIRS  
1591 CPT 2.00      240.00      240.00  
PARTS: 0.00 LABOR: 240.00 OTHER: 0.00 TOTAL LINE AA: 240.00  
REPAIRED DAMAGED REAR GEAR STOW-LOCKS & ADJUSTED. TESTED OPERATION  
- GOOD

\*\*\*\*\*  
AB\*\*CHECK AND ADVISE FOR CLICKING NOISE FROM FRONT END WHEN IN 4X4  
CAUSE: HUB LOCK  
1105A HUB LOCK ASSEMBLY - REPLACE (1K105/3B396) -  
L  
1591 WT 0.60      (N/C)  
1 BC3Z\*3B396\*A LINK ASY - FRONT AXL      (N/C)  
FC: P82 42  
PART#: BC3Z\*3B396\*A  
COUNT:  
CLAIM TYPE:  
AUTH CODE:  
1591

PARTS: 0.00 LABOR: 0.00 OTHER: 0.00 TOTAL LINE AB: 0.00  
ROAD TESTED & CONFIRMED CLICKING TYPE NOISE FROM L/F IN 4X4. RAN ON  
HOIST TO CONFIRM. REMOVED LEFT FRONT HUB LOCK & FOUND BROKEN IN PIECES.

**STATEMENT OF DISCLAIMER**

The factory warranty constitutes all of the warranties with respect to the sale of this item/items. The Seller hereby expressly disclaims all warranties either express or implied, including any implied warranty of merchantability or fitness for a particular purpose. Seller neither assumes nor authorizes any other person to assume for it any liability in connection with the sale of this item/items.

I agree to receive E-mails, texts and other electronic communications containing promotions, news updates and other promotional material regarding Go Auto's and Go Insurance's products and services.

DESCRIPTION	TOTALS
LABOUR AMOUNT	
PARTS AMOUNT	
GAS, OIL, LUBE	
SUBLET AMOUNT	
MISC. CHARGES	
TOTAL CHARGES	
LESS INSURANCE	
SALES TAX	
<b>PLEASE PAY THIS AMOUNT</b>	

CUSTOMER SIGNATURE

DATE

CUSTOMER #:  
UNIT# 157912

600156



**TEAM FORD**

DRIVING FORCE LEDUC  
8336 SPARROW CRESCENT  
LEDUC, AB T9E 8B7  
HOME:780-930-3659 CONT:780-930-3659  
BUS: CELL:

INVOICE

3304 - 91st Street, Edmonton, AB T6N 1C1  
Tel: 780-462-8300 Fax: 780-461-0055  
www.teamford.ca

PAGE 10

SERVICE ADVISOR: 410 ROBERT KRAUSE

COLOUR	YEAR	MAKE/MODEL	VIN	LICENSE	ODOMETER IN/ OUT	TAG	
WHITE	19	FORD F550	1FD0W5HT4KEE14684	UNIT55	116425/118362	T2910	
DEL DATE	PROD. DATE	WARR. EXP.	PROMISED	PO NO.	RATE	PAYMENT	INV. DATE
25FEB19 DD			17:00 14MAR22	UNIT55	110.00	CHG	29MAR22
R.O. OPENED		READY		OPTIONS: DLR:B6210 ENG:6.7_Liter			
08:42 23FEB22		07:45 29MAR22					

LINE	OPCODE	TECH	TYPE	HOURS	LIST	NET	TOTAL
------	--------	------	------	-------	------	-----	-------

REPLACED L/F HUB LOCK ASSEMBLY & RE-TESTED OPERATION - GOOD.  
\*\*\*\*\*

AC\*\*REPLACE PRIMARY AND SECONDARY DIESEL FILTERS  
CAUSE: MAINT.  
210 REPLACE PRIMARY AND SECONDARY DIESEL FILTERS  
1591 CPT 1.00 120.00 120.00  
PARTS: 0.00 LABOR: 120.00 OTHER: 0.00 TOTAL LINE AC: 120.00  
REPLACED BOTH PRIMARY & SECONDARY FUEL FILTERS. BLED AIR FROM FUEL SYSTEM & STARTED TRUCK  
\*\*\*\*\*

AD\*\*REPAIR MARKER LIGHT  
CAUSE: BURNT OUT  
152 BULBS ( EXTRA TIME MAY BE REQUIRED DEPENDING ON VEHICLE)  
1591 CPT 0.30 19.95 19.95  
1 G3002EA 2" RED LED 18.50 11.65 11.65  
1 67001 PIGTAIL 8.50 4.80 4.80  
PARTS: 16.45 LABOR: 19.95 OTHER: 0.00 TOTAL LINE AD: 36.40  
REPLACED R/R SIDE MARKER LIGHT & PIGTAIL. TESTED OPERATION - GOOD.  
\*\*\*\*\*

AE\*\*CHECK AND ADVISE FOR CHECK ENGINE LIGHT COMING ON  
CAUSE: POOR CONNECTION  
1000 DIESEL ENGINE  
1591 CPT 0.00 0.00 0.00  
PARTS: 0.00 LABOR: 0.00 OTHER: 0.00 TOTAL LINE AE: 0.00  
CHECKED FOR DTC CODES. PERFORMED KOEO SELF TEST. FOUND DTC CODE P2454. PERFORMED DIAG & FOUND POOR CONNECTION AT DPFE SENSOR. CLEANED & ADDED DI-ELECTRIC GREASE. RETESTED - GOOD.  
\*\*\*\*\*

SHOP SUPPLIES. 12% OF LABOUR UP TO \$90 PER RO. 100.00

G.S.T. R105153712

582.44

**STATEMENT OF DISCLAIMER**

The factory warranty constitutes all of the warranties with respect to the sale of this item/items. The Seller hereby expressly disclaims all warranties either express or implied, including any implied warranty of merchantability or fitness for a particular purpose. Seller neither assumes nor authorizes any other person to assume for it any liability in connection with the sale of this item/items.

I agree to receive E-mails, texts and other electronic communications containing promotions, news updates and of CARIBOO.OPS22 regarding Go Auto's and Go Insurance's products and services. Job Code:

Task Code: A99

CUSTOMER SIGNATURE  
Equipment Unit #: 55

DocuSigned by:  
*Tammy Froelich* DATE  
275231AF148B49C...

DESCRIPTION	TOTALS
LABOUR AMOUNT	5257.85
PARTS AMOUNT	6287.33
GAS, OIL, LUBE	0.00
SUBLET AMOUNT	0.00
MISC. CHARGES	103.70
TOTAL CHARGES	11648.88
LESS INSURANCE	0.00
SALES TAX	582.44
<b>PLEASE PAY THIS AMOUNT</b>	<b>12231.32</b>

Comment: HI-RAIL, CVIP & REPAIRS, 2022

Rec May 06/22



## Railgear Alignment Sheet

GAS OR DIESEL

VIN# 1FD0W5HT4KEE14684

VEHICLE MAKE: Ford VEHICLE MODEL: F-550 VEHICLE YEAR: 2019  
 DOOR STICKER GVWR: 2845 kg DOOR STICKER GAWR FRT: 3175 kg DOOR STICKER GAWR RR: 6671 kg  
 RAILGEAR S/N: FRT 050356 RR 017227 VEHICLE UNIT #, S/N:  
 RAILGEAR TYPE: LAFNA 2-450 INSTALLER: Don DeJong DATE: March 17/22

SET UP PARALLEL STRING LINES  
 A & B MUST BE EQUAL WITHIN 1/32"  
 C & D MUST BE EQUAL WITHIN 1/32"

ADJUST STRING LINES AROUND VEHICLE  
 E, F, G, & H MUST BE EQUAL WITHIN 1/16"  
 I, J, K, & L MUST BE EQUAL WITHIN 1/16"  
 (E, F, G, & H MAY NOT EQUAL I, J, K, & L)

ADJUST RAIL WHEEL ALIGNMENT  
 M & O MUST BE EQUAL WITHIN 1/16"  
 N & P MUST BE EQUAL WITHIN 1/16"  
 Q & S MUST BE EQUAL WITHIN 1/16"  
 R & T MUST BE EQUAL WITHIN 1/16"

ADJUST RAILGEAR LATERAL ALIGNMENT  
 M & O MUST EQUAL N & P WITHIN 1/8"  
 Q & S MUST EQUAL R & T WITHIN 1/8"

ENSURE THAT U & V ARE BETWEEN  
 53- 7/16" AND 53- 9/16"

OVER-CENTER ANGLE (DEGREE)  
 FRONT \_\_\_\_\_  
 REAR \_\_\_\_\_

TREAD TO TREAD, (NOT SIDEWALL)  
 OEM FRONT: \_\_\_\_\_  
 OEM REAR: \_\_\_\_\_  
 MODIFIED FRONT: \_\_\_\_\_  
 MODIFIED REAR: \_\_\_\_\_

RAIL WHEEL LOADS (LBS)  
 LEFT FRONT \_\_\_\_\_ RIGHT FRONT \_\_\_\_\_  
 LEFT REAR \_\_\_\_\_ RIGHT REAR \_\_\_\_\_

RAIL WHEEL FLANGE TO GROUND CLEARANCE  
 LEFT FRONT 6-1/2 RIGHT FRONT 6-9/16  
 LEFT REAR 8-1/2 RIGHT REAR 8

TIRE MFG \_\_\_\_\_  
 TIRE SIZE \_\_\_\_\_

MOUNTING HEIGHT FRONT:

STOCK TURNING DIAMETER:

OEM: VEHICLE WEIGHT:

MODIFIED: VEHICLE WEIGHT: \_\_\_\_\_

MOUNTING HEIGHT REAR:

MODIFIED TURNING DIAMETER:

FRONT GAWR:

REAR GAWR:

FRONT GAWR: \_\_\_\_\_

REAR GAWR: \_\_\_\_\_

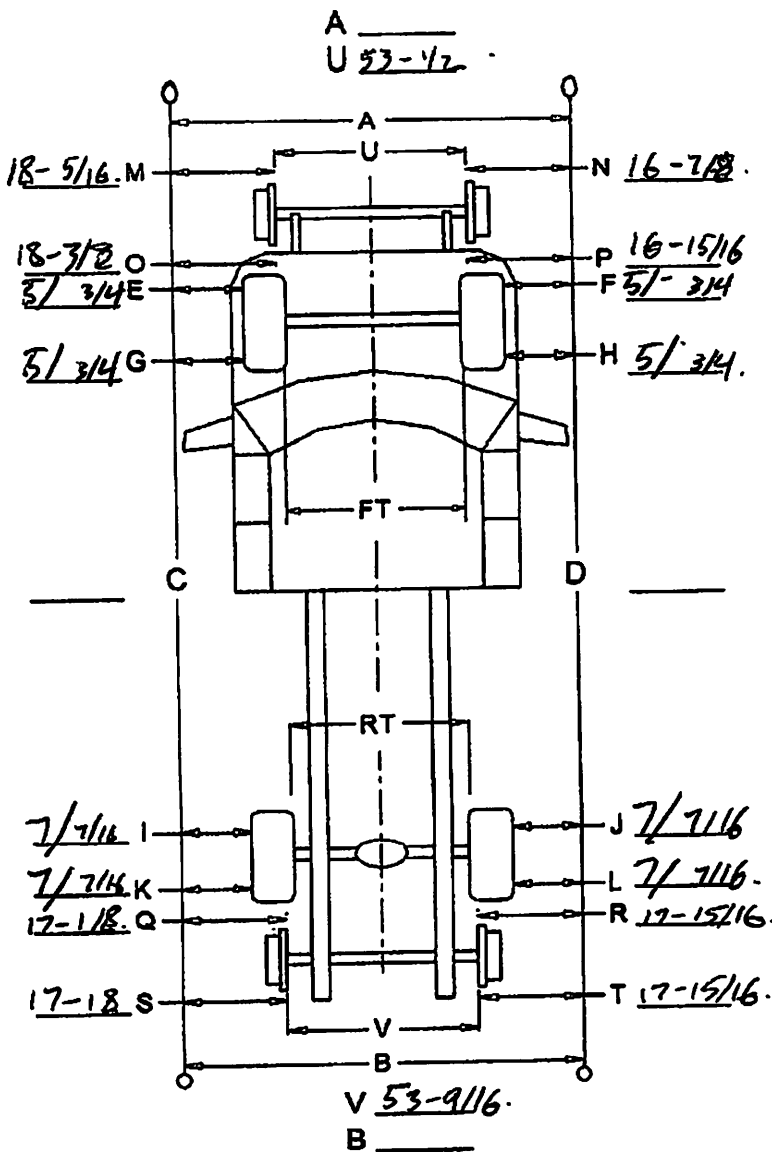

CUSTOMER #:

207190

Terry Ortynsky's  
**ROYAL**  
FORD

Phone (306) 782-2261  
Parts (306) 783-8559  
Fax (306) 786-6515  
Email customerservice@royalford.ca  
www.terryortynsky.com  
81 Dracup Avenue  
Yorkton, SK S3N 3P9  
GST# 104644364

\*INVOICE\*

DUPLICATE 1  
PAGE 1

*We Make It Easy!*

CARIBOU RAIL  
209 307 BANKS RD  
Kelowna, BC V1X 6A1  
HOME: 778-478-1746 CONT: 778-478-1746  
BUS: CELL: SERVICE ADVISOR: 163 MICHELLE CAMPBELL

COLOUR	YEAR	MAKE/MODEL	VIN	LICENSE	ODOMETER IN/ OUT	TAG	
	19	FORD F550	1FD0W5HT4KEE14684		104390/104403	T14684	
DEL DATE	PROD. DATE	WARR. EXP.	PROMISED	PO NO.	RATE	PAYMENT	INV. DATE
01JAN19 DD			10:42 04DEC21		140.00	DC	10DEC21
R.O. OPENED	READY	OPTIONS: DLR: B4016					
08:50 04DEC21	13:59 10DEC21						

LINE	OPCODE	TECH	TYPE	HOURS	LIST	NET	TOTAL	
A DRIVER STATES THAT UNIT JUST HAD A OIL PAN GASKET REPLACED AT CAPITAL PICKED IT UP YESTERDAY AND DRIVING IT LAST NIGHT THE VEHICLE SHOWED A DIESEL FUEL LEAK FROM WHAT LOOKS TO BE THE FUEL FILTER HOUSING UNSURE IF RELATED TO REPAIR OR NOT								
98 DRIVER STATES THAT UNIT JUST HAD A OIL PAN GASKET REPLACED AT CAPITAL PICKED IT UP YESTERDAY AND DRIVING IT LAST NIGHT THE VEHICLE SHOWED A DIESEL FUEL LEAK FROM WHAT LOOKS TO BE THE FUEL FILTER HOUSING UNSURE IF RELATED TO REPAIR OR NOT								
				116 CMS		1.25		
				128 CMS		3.13		
						4.38		
				1 HC3Z*9J338*L TUBE	356.60	356.60	356.60	
PARTS: 105490					356.60	LABOR: 613.20	OTHER: 0.00	TOTAL LINE A: 969.80

check for cause of fuel leak. found fuel supply line to engine fuel filter is pouring fuel all over . major leak. remove fuel filter and inmspect to see if filter is cracked, fiter is ok. inspect fuel line and found that the seals inside the line are missing and retainer is also missing inside of line. the only thing inside the line is nylon separator ring.  
found some orings to put on just to drive truck out of bay. line needs to be replaced.  
wash off fuel under hood.  
REMOVED AND REPLACED DAMAGED FUEL LINE AS PER PREVIOUS DIAGNOSIS.  
ROAD TEST AND IS OK NOW. TRUCK IS COVERED IN FUEL UNDER NEATH AND IS SOAKED INTO THE INSULATION. WILL LIKELY SMOKE AND SMELL FOR AWHILE UNTIL IT ALL BURNS OFF.

\*\*\*\*\*

TERMS: STRICTLY CASH UNLESS ARRANGEMENTS MADE	ALL ITEMS SUBJECT TO G.S.T.	DESCRIPTION	TOTALS
I HEREBY AUTHORIZE THE REPAIR WORK SET FORTH TO BE DONE ALONG WITH THE NECESSARY MATERIAL AND AGREE TO THE EXTENT PERMITTED BY LAW. YOU ARE NOT RESPONSIBLE FOR LOSS OR DAMAGE TO VEHICLE OR ARTICLES LEFT IN VEHICLE IN THE CASE OF FIRE, THEFT OR ANY OTHER CAUSE BEYOND YOUR CONTROL OR FOR ANY DELAYS CAUSED BY UNAVAILABILITY OF PARTS OR DELAYS IN PARTS SHIPMENTS BY THE SUPPLIER OR TRANSPORTER. I HEREBY GRANT YOU AND OR YOUR EMPLOYEES, PERMISSION TO OPERATE THE VEHICLE HEREIN DESCRIBED ON STREETS, HIGHWAYS OR ELSEWHERE FOR THE PURPOSE OF TESTING AND/OR INSPECTION. UNTIL PAYMENT IN FULL OF THE WITHIN ACCOUNT, I HEREBY ACKNOWLEDGE THE EXISTENCE OF A MECHANIC'S LIEN IN FAVOUR OF THE WITHIN DEALER ON THE VEHICLE DESCRIBED HEREIN IN RESPECT OF THE MATERIAL SUPPLIED AND SERVICES RENDERED UNDER THIS WORK ORDER FOR THE FULL AMOUNT CHARGED THEREFORE. I FURTHER ACKNOWLEDGE THAT THE SAID LIEN SHALL CONTINUE IN FORCE AT ALL TIMES, WHETHER THE VEHICLE IS IN MY POSSESSION IT SHALL BE SUBJECT TO REPOSSESSION ON DEMAND BY THE DEALER UNTIL THE WITHIN ACCOUNT IS PAID IN FULL.		LABOUR AMOUNT	
		PARTS AMOUNT	
		GAS, OIL, LUBE	
		SUBLET AMOUNT	
		MISC. CHARGES	
		TOTAL CHARGES	
		LESS INSURANCE	
		SALES TAX	
		<b>PLEASE PAY THIS AMOUNT</b>	

INDEBTEDNESS IS HEREBY ACKNOWLEDGED IN THE SUM OF \$ \_\_\_\_\_ BEING ALL OR THE BALANCE OWING FOR REPAIRS, PARTS AND ACCESSORIES DESCRIBED IN THIS WORK ORDER. ALL WARRANTY SUBJECT TO FACTORY ACCEPTANCE. DATE \_\_\_\_\_ SIGNATURE \_\_\_\_\_

CUSTOMER #:

207190

Terry Ortynsky's

Phone (306) 782-2261  
 Parts (306) 783-8559  
 Fax (306) 786-6515  
 Email customerservice@royalford.ca  
 www.terryortynsky.com  
 81 Dracup Avenue  
 Yorkton, SK S3N 3P9  
 GST# 104644364

**ROYAL FORD**

*We Make It Easy!*

\*INVOICE\*

DUPLICATE 1  
 PAGE 2

CARIBOU RAIL  
 209 307 BANKS RD  
 Kelowna, BC V1X 6A1  
 HOME: 778-478-1746 CONT: 778-478-1746

BUS: CELL: SERVICE ADVISOR: 163 MICHELLE CAMPBELL

COLOUR	YEAR	MAKE/MODEL	VIN	LICENSE	ODOMETER IN/ OUT	TAG	
	19	FORD F550	1FD0W5HT4KEE14684		104390/104403	T14684	
DEL DATE	PROD. DATE	WARR. EXP.	PROMISED	PO NO.	RATE	PAYMENT	INV. DATE
01JAN19 DD			10:42 04DEC21		140.00	DC	10DEC21
R.O. OPENED	READY	OPTIONS: DLR: B4016					
08:50 04DEC21	13:59 10DEC21						

LINE	OPCODE	TECH	TYPE	HOURS	LIST	NET	TOTAL
EST:	0.00			04DEC21 08:50	SA: 164		

CONTACT:

\*\*\*\*\*

SHOP SUPPLIES

67.45

Job Code: C.SK.PANDH.YOR

Task Code: A16NB

Equipment Unit #: 55

Comment: FUEL LEAK

DocuSigned by:

*Tammy Froelich*  
 275231AF148B49C...

Dec 15, 2021

Rec Dec 10/21

GST (#: R104644364) 51.86  
 PST 62.22

TERMS: STRICTLY CASH UNLESS ARRANGEMENTS MADE	ALL ITEMS SUBJECT TO G.S.T.	DESCRIPTION	TOTALS
I HEREBY AUTHORIZE THE REPAIR WORK SET FORTH TO BE DONE ALONG WITH THE NECESSARY MATERIAL AND AGREE TO THE EXTENT PERMITTED BY LAW, YOU ARE NOT RESPONSIBLE FOR LOSS OR DAMAGE TO VEHICLE OR ARTICLES LEFT IN VEHICLE IN THE CASE OF FIRE, THEFT OR ANY OTHER CAUSE BEYOND YOUR CONTROL OR FOR ANY DELAYS CAUSED BY UNAVAILABILITY OF PARTS OR DELAYS IN PARTS SHIPMENTS BY THE SUPPLIER OR TRANSPORTER. I HEREBY GRANT YOU AND OR YOUR EMPLOYEES, PERMISSION TO OPERATE THE VEHICLE HEREIN DESCRIBED ON STREETS, HIGHWAYS OR ELSEWHERE FOR THE PURPOSE OF TESTING AND/OR INSPECTION. UNTIL PAYMENT IN FULL OF THE WITHIN ACCOUNT, I HEREBY ACKNOWLEDGE THE EXISTENCE OF A MECHANIC'S LIEN IN FAVOUR OF THE WITHIN DEALER ON THE VEHICLE DESCRIBED HEREIN IN RESPECT OF THE MATERIAL SUPPLIED AND SERVICES RENDERED UNDER THIS WORK ORDER FOR THE FULL AMOUNT CHARGED THEREFORE. I FURTHER ACKNOWLEDGE THAT THE SAID LIEN SHALL CONTINUE IN FORCE AT ALL TIMES, WHETHER THE VEHICLE IS IN MY POSSESSION IT SHALL BE SUBJECT TO REPOSSESSION ON DEMAND BY THE DEALER UNTIL THE WITHIN ACCOUNT IS PAID IN FULL.		LABOUR AMOUNT	613.20
		PARTS AMOUNT	356.60
		GAS, OIL, LUBE	0.00
		SUBLET AMOUNT	0.00
		MISC. CHARGES	67.45
		TOTAL CHARGES	1037.25
		LESS INSURANCE	0.00
		SALES TAX	114.08
		PLEASE PAY THIS AMOUNT	1151.33

**PRIVACY**  
 Personal information is collected in accordance with applicable privacy legislation and is governed by Terry Ortynsky Ford Privacy Policy. Ask us if you would like information about our Privacy Policy, including our service providers and their data processing in the U.S., which may be accessible to U.S. law enforcement and national security authorities.  
 We provide this personal and transaction information to Ford Motor Company of Canada, Limited to enable Ford to administer your transaction, provide you with requested services, improve automotive related products and services by conducting customer surveys, and provide you with marketing material which may be of interest to you, as permitted by applicable laws. For the Ford Privacy Policy (www.ford.ca) including use of service providers and U.S. data storage or if you do not want to receive marketing or survey materials from Ford please call 1-800-565-FORD (3673).

INDEBTEDNESS IS HEREBY ACKNOWLEDGED IN THE SUM OF \$ \_\_\_\_\_ BEING ALL OR THE BALANCE OWING FOR REPAIRS, PARTS AND ACCESSORIES DESCRIBED IN THIS WORK ORDER. ALL WARRANTY SUBJECT TO FACTORY ACCEPTANCE. DATE \_\_\_\_\_ SIGNATURE \_\_\_\_\_

CUSTOMER COPY

**Falcon Equipment - Regina**

369 Sherwood Road, North West  
Regina, SK S0G 5K0  
306-352-4266 - Fax 306-352-4660

Inv # 523003542

Inv Date 06/11/2021

Terms - 30 Days

**Service Invoice**

Salesman: House Account Writer:

<b>BILL TO:</b>	<b>SHIP TO:</b>
CARIBOO CENTRAL RAILROAD CONTRACTING LTD.	CARIBOO CENTRAL RAILROAD CONTRACT
#209 - 307 BANKS ROAD KELOWNA, BC V1X 6A1	#209 - 307 BANKS ROAD KELOWNA, BC V1X 6A1
778-478-1745 - Fax 778-478-1746	778-478-1745

<b>PO #</b>	<b>Make</b>	<b>Model</b>	<b>Serial #</b>	<b>Unit #</b>	<b>Meter</b>
<b>UNIT 55</b>	FORD	F550	1FD0W5HT8KEE14684	55	30378

**WORK TO BE COMPLETED:**  
-Replace bent front rail brackets

**WORK COMPLETED:**  
-Remove front rail gear and replaced mounting brackets  
-Realign the rail gear  
-Refill the rail gear pump.  
-Retest found that the rear rail gear will not fully retract, and rear rail gear lock will not move.  
-Grease all points on the rear rail gear

<b>Part#</b>	<b>Warehouse Description</b>	<b>Bin</b>	<b>Qty</b>	<b>BO</b>	<b>Shipped</b>	<b>Each</b>	<b>Extended</b>
LU313BC	Regina MainBRAKE CLEANER, KLEEN FLO	PARTS ROO.2	0	2		4.57	9.14
Bolts			1	0	1		95.82
PBR00609	FRONT DRIVER SIDE MOUNTING SBRACKET		1	0	1		485.00
PBR00610	FRONT PASSENGER SIDE MOUNTING PLATE		1	0	1		485.00
	FRONT PLATE TIE BAR		1	0	1		210.92
	FREIGHT		1	0	1		385.00
	Shop Supplies		1	0	1		177.70
<b>Sub Total</b>							<b>1,848.58</b>

**01. R&r front rail gear to replace mounts**

<b>Part#</b>	<b>Warehouse Description</b>	<b>Bin</b>	<b>Extended</b>
Flat Rate Labor	<b>Job Code:</b> SK.CN.UNI55.HR		1,300.00
	<b>Task Code:</b> A16NB		
	<b>Equipment Unit #:</b> Unit 55		
	<b>Comment:</b> repairs		
<b>01. R&amp;r front rail gear to replace mounts Sub Total</b>			<b>1,300.00</b>

DocuSigned by:

Cam Fraser

Jun 18, 2021

12188F15F0CD418...

Notice: CLAIMS AGAINST **Rec Jun 16/21** SERVICE WILL NOT BE ACCEPTED AFTER 14 DAYS FROM RECEIPT OF GOODS.

Terms: Net 30 days from invoice date unless otherwise indicated. Interest charged at 1% / 12.67% per annum per month.

Return Policy: Returns must be within 30 days of purchase and are subject to restocking charges and will not be accepted without authorization and accompanying documentation. Special order and electrical parts are non-returnable. Freight charges are non-refundable.

<b>REMIT PAYMENTS TO:</b>	FALCON EQUIPMENT LTD.	GST/HST# 139129084	<b>Sub Total</b>	<b>\$3,148.58</b>
	18412 - 96 AVE	BC PST# 1000-5054	<b>PST</b>	<b>\$220.40</b>
	SURREY, BC	SK PST# 2548022	<b>GST</b>	<b>\$157.43</b>
	V4N 3P8	MB RST# 967076-1	<b>Total</b>	<b>\$3,526.41</b>



1201 Pasqua St. N.  
Regina, Saskatchewan, S4X 4P7  
www.capitalfordlincoln.ca  
Phone: (306) 543-5410  
Fax: (306) 543-0839



CELL: 604-613-5005

G.S.T. No. 86587 2618 RT

ALL ITEMS ARE SUBJECT TO G.S.T.

O U T	INDEBTEDNESS IS HEREBY ACKNOWLEDGED IN THE SUM OF \$		BEING ALL OR THE BALANCE OWING FOR	
	REPAIRS, PARTS & ACCESSORIES DESCRIBED IN THIS WORK ORDER. INTEREST CHARGED AT 2 1/2% PER MONTH (30% PER ANNUM) CHARGED ON OVERDUE ACCOUNTS.			
DATE	SIGNATURE			
CUSTOMER NUMBER	ADVISOR	TAG NO.	INVOICE DATE	INVOICE NO.
CARIBOO RAIL 307 BANKS RD KELOWNA, BC V1X 6A1	KEIL RUDNISKI	661 6110	05/05/21	ECCS760704
	LABOUR RATE	LICENSE NO.	KILOMETRES	COLOUR
			80,950	
	YEAR/MAKE/MODEL	DELIVERY DATE		DELIVERY KMS.
	19/FORD TRUCK/SUPER DUTY F-55/			
	VEHICLE ID. NO.	SELLING DEALER NO.	PRODUCTION DATE	
	1 F D O W 5 H T 4 K E E 1 4 6 8 4			
	F.T.E. NO.	P.O. NO.	R.O. DATE	IN SERVICE DATE
			04/29/21	
COMMENTS				

LABOR & PARTS

J# 1 00FOZZ08MAINT1 LUBE OIL FILTER DSL TECH(S):777 65.75  
 COMPLAINT: PERFORM LUBE, OIL AND FILTER AS PER CUSTOMER REQUEST  
 3/4 TON AND UP DIESEL APPLICATIONS  
 RESET OIL LIGHT  
 CORRECTION: COMPLETED LUBE, OIL AND FILTER

PARTS	QTY	FP-NUMBER	DESCRIPTION	LIST PRICE	UNIT PRICE	PRICE
JOB # 1	1	FL-2051-S	KIT - E D09	55.30	30.95	30.95
JOB # 1	13	CX0-10W30-BSO	OIL - E Z02	5.95	5.00	65.00
JOB # 1	2	CPM-27-JA	EXHAUST D02	30.00	21.42	42.84
JOB # 1 TOTAL PARTS						138.79
JOB # 1 TOTAL LABOR & PARTS						204.54

J# 2 18FOZ \*AIR CONDITIONING TECH(S):777 335.00  
 COMPLAINT: A/C INOP  
 CORRECTION: VERIFIED CUSTOMER CONCERN, FOUND A/C INOP ON ROAD TEST, FOUND COMPRESSOR NOT TURNING ON, CHECKED FUSES AND POWER AND GROUND, ALL OK, CHECKED FOR THE CORRECT FREEON AMOUNT IN SYSTEM, FOUND NO FREEON IN SYSTEM, PRESSURED SYSTEM AND BLACK LIGHT AROUND TRUCK, FOUND NO LEAKS AND DID NOT LOSE PRESSURE, FILLED UP FREEON, ROAD TEST, FOUND A/C COMPRESSOR NOW ON BUT THE A/C STILL INOP, CHECKED PRESSURES, FOUND PRESSURES NOT MOVING, FOUND A/C COMPRESSOR INOP, SUSPECT INTERNAL FAILURE OF THE A/C COMPRESSOR, THE SYSTEM WILL NEED TO BE FLUSHED AND THE COMPRESSOR REPLACED, NO REPAIR AT THIS TIME, CUSTOMER TO TAKE

PARTS	QTY	FP-NUMBER	DESCRIPTION	LIST PRICE	UNIT PRICE	PRICE
JOB # 2	0	YCC-424	COMPRES Z00	872.92	872.92	0.00
PART ON SPECIAL ORDER ** QUANTITY 1 IS SPECIAL ORDERED **						
JOB # 2 TOTAL PARTS						0.00
JOB # 2 TOTAL LABOR & PARTS						335.00

J# 3 15FOZ MISC REPAIRS/SUBLETS TECH(S):777 167.50  
 COMPLAINT: WATER TANK PUMP INOP  
 CORRECTION: VERIFIED CUSTOMER CONCERN, FOUND WATER TANK PUMP INOP, TRACED WIRES, FOUND THE CIRCUITS OPEN, REPAIRED WITH NEW WIRE, ALSO FOUND THE FUSE HOLDER CORRODED, REPLACED, RETESTED PUMP, ALL OK, PUMP NOW WORKS

PARTS	QTY	FP-NUMBER	DESCRIPTION	LIST PRICE	UNIT PRICE	PRICE
JOB # 3 TOTAL PARTS						0.00
JOB # 3 TOTAL LABOR & PARTS						167.50

J# 4 30FODRECOMMEND NEXT VISIT TECH(S):777 INTERNAL  
 COMPLAINT: SERVICE RECOMMENDED NEXT VISIT  
 CORRECTION: 88000 KMS SERVICE MAINT PACK 2

MO: 80955



No Appointment Necessary

- ✓ Oil Changes
- ✓ Brakes
- ✓ Tires
- ✓ Alignments
- ✓ Belts & Hoses
- ✓ Tune-Up
- ✓ Shocks & Struts
- ✓ Exhaust System
- ✓ Cooling System

PRIVACY STATEMENT

Ask us if you would like information about our Privacy Policy, including our service providers and their data processing in the U.S., which may be accessible to U.S. law enforcement and national security authorities. We provide this personal and transaction information to Ford Motor Company of Canada, Limited to enable Ford to administer your transaction, provide you with requested services, improve automotive related products and services by conducting customer surveys, and provide you with marketing material which may be of interest to you, as permitted by applicable laws. For the Ford Privacy Policy ([www.ford.ca](http://www.ford.ca)) including use of service providers and U.S. data storage or if you do not want to receive marketing or survey materials from Ford please call 1-800-565-FORD (3673).



1201 Pasqua St. N.  
Regina, Saskatchewan, S4X 4P7  
www.capitalfordlincoln.ca  
Phone: (306) 543-5410  
Fax: (306) 543-0839



CELL: 604-613-5005

G.S.T. No. 86587 2618 RT

ALL ITEMS ARE SUBJECT TO G.S.T.

O U T	INDEBTEDNESS IS HEREBY ACKNOWLEDGED IN THE SUM OF \$		BEING ALL OR THE BALANCE OWING FOR	
	REPAIRS, PARTS & ACCESSORIES DESCRIBED IN THIS WORK ORDER. INTEREST CHARGED AT 2 1/2% PER MONTH (30% PER ANNUM) CHARGED ON OVERDUE ACCOUNTS.			
DATE	SIGNATURE			
ADVISOR	TAG NO.	INVOICE DATE	INVOICE NO.	
KELI RUDNISKI	661 6110	05/05/21	FCCS760704	
LABOUR RATE	LICENSE NO.	KILOMETRES	COLOUR	STOCK NO.
		80,950		
YEAR/MAKE/MODEL	DELIVERY DATE		DELIVERY KMS.	
19/FORD TRUCK/SUPER DUTY F-55/				
VEHICLE ID. NO.	SELLING DEALER NO.		PRODUCTION DATE	
1 F D O W 5 H T 4 K E E 1 4 6 8 4				
P.T.E. NO.	R.O. DATE		IN SERVICE DATE	
	04/29/21			
BUSINESS PHONE	COMMENTS			

PARTS	QTY	FP-NUMBER	DESCRIPTION	LIST PRICE	UNIT PRICE	PRICE
JOB # 4 TOTAL PARTS 0.00						
JOB # 4 TOTAL LABOR & PARTS 0.00						
J# 5 01FOZ99P		QC 550 NON QUICKLANE	TECH(S):777			INTERNAL
COMPLAINT: FORD QUALITY INSPECTION						
CORRECTION: COMPLETED QC550 FORD COURTESY INSPECTION						
JOB # 5 TOTAL PARTS 0.00						
JOB # 5 TOTAL LABOR & PARTS 0.00						
J# 6 01FOZGTIRE		7/32" AND GREATER	TECH(S):777			INTERNAL
COMPLAINT: CHECK TIRE TREAD AND CONDITION						
CORRECTION: 14-17/32"						
JOB # 6 TOTAL PARTS 0.00						
JOB # 6 TOTAL LABOR & PARTS 0.00						
J# 7+12FOZZ17		*WIPER BLADE(S)	TECH(S):777			0.00
COMPLAINT: REPLACE WIPER BLADES						
CORRECTION: REPLACE WIPER BLADES						
JOB # 7	2	WW-2202-PF	BLADE A D10	32.83	19.95	39.90
JOB # 7 TOTAL PARTS 39.90						
JOB # 7 TOTAL LABOR & PARTS 39.90						
J# 8+00FOZZPOLLEN		POLLEN/CABIN FILTER	TECH(S):777			50.00
COMPLAINT: REPLACE POLLEN/MICRO FILTER						
CORRECTION: REPLACED POLLEN/MICRO FILTER						
JOB # 8	1	FP-92	FILTER D09	49.42	49.42	49.42
JOB # 8 TOTAL PARTS 49.42						
JOB # 8 TOTAL LABOR & PARTS 99.42						
J# 9+00FOZZAIR		AIR FILTER	TECH(S):777			6.00
COMPLAINT: REPLACE ENGINE AIR FILTER						
CORRECTION: REPLACED ENGINE AIR FILTER						
JOB # 9	1	FA-1927	ELEMENT D09	125.37	125.37	125.37
JOB # 9 TOTAL PARTS 125.37						
JOB # 9 TOTAL LABOR & PARTS 131.37						
J#10+00FOZZZ2		FUEL FILTER DIESEL	TECH(S):777			126.50
COMPLAINT: REPLACE FUEL FILTERS						

MO: 80955



No Appointment Necessary

- ✓ Oil Changes
- ✓ Brakes
- ✓ Tires
- ✓ Alignments
- ✓ Belts & Hoses
- ✓ Tune-Up
- ✓ Shocks & Struts
- ✓ Exhaust System
- ✓ Cooling System

PRIVACY STATEMENT

Ask us if you would like information about our Privacy Policy, including our service providers and their data processing in the U.S., which may be accessible to U.S. law enforcement and national security authorities. We provide this personal and transaction information to Ford Motor Company of Canada, Limited to enable Ford to administer your transaction, provide you with requested services, improve automotive related products and services by conducting customer surveys, and provide you with marketing material which may be of interest to you, as permitted by applicable laws. For the Ford Privacy Policy ([www.ford.ca](http://www.ford.ca)) including use of service providers and U.S. data storage or if you do not want to receive marketing or survey materials from Ford please call 1-800-565-FORD (3673).





1201 Pasqua St. N.  
Regina, Saskatchewan, S4X 4P7  
www.capitalfordlincoln.ca  
Phone: (306) 543-5410  
Fax: (306) 543-0839



CELL: 604-613-5005

**O U T** INDEBTEDNESS IS HEREBY ACKNOWLEDGED IN THE SUM OF \$ \_\_\_\_\_ BEING ALL OR THE BALANCE OWING FOR REPAIRS, PARTS & ACCESSORIES DESCRIBED IN THIS WORK ORDER. INTEREST CHARGED AT 2 1/2% PER MONTH (30% PER ANNUM) CHARGED ON OVERDUE ACCOUNTS.

G.S.T. No. 86587 2618 RT

ALL ITEMS ARE SUBJECT TO G.S.T.

CUSTOMER NUMBER	ADVISOR	TAG NO.	INVOICE DATE	INVOICE NO.
CARIBOO RAIL 307 BANKS RD KELOWNA, BC V1X 6A1	KETI RUDNISKI	661 6110	05/05/21	FCCS760704
	LABOUR RATE	LICENSE NO.	KILOMETRES	COLOR
			80,950	
	YEAR/MAKE/MODEL	DELIVERY DATE	DELIVERY KMS.	
	19/FORD TRUCK/SUPER DUTY F-55/			
	VEHICLE ID. NO.	SELLING DEALER NO.	PRODUCTION DATE	
	1 F D O W 5 H T 4 K E E 1 4 6 8 4			
	P.T.E. NO.	R.O. DATE	IN SERVICE DATE	
		04/29/21		
BUSINESS PHONE	COMMENTS	MO: 80955		

TOTALS-----

WHAT ARE SHOP SUPPLIES?

Shop supplies are extra materials that are necessary on most repairs or maintenance to ensure the service is performed to your satisfaction. Some examples are:  
Lubricants, cleaners, sand paper for brakes, oxy-acetylene gas to heat up & remove seized bolts. Disposal/recycling of hazardous materials. Shims or weights necessary on wheel aligning & balance. Grease, lubricants for bearings, latches or hinges. Adhesives, foam tape for loose trim or weatherstrips. Tape, wire connectors, tie straps for wiring repairs. Floor mats, seat covers to protect vehicles interior.

TOTAL LABOR....	801.00
TOTAL PARTS....	577.06
TOTAL SUBLET...	0.00
TOTAL G.O.G....	47.60
TOTAL MISC CHG.	72.97
TOTAL MISC DISC	0.00
TOTAL TAX.....	164.85
<b>TOTAL INVOICE \$</b>	<b>1663.48</b>

ATTENTION: PLEASE CHECK WHEELS NUTS & RETORQUE AFTER 100 KM'S

CUSTOMER SIGNATURE

Job Code: SK.CN.Unit.55.HR

Task Code: A16NB

Equipment Unit #: Unit 55

Comment: repairs

DocuSigned by:  
*Cam Fraser*  
12188F15F0CD418...  
May 10, 2021

Received May 6/21



No Appointment Necessary

- ✓ Oil Changes
- ✓ Brakes
- ✓ Tires
- ✓ Alignments
- ✓ Belts & Hoses
- ✓ Tune-Up
- ✓ Shocks & Struts
- ✓ Exhaust System
- ✓ Cooling System

PRIVACY STATEMENT

Ask us if you would like information about our Privacy Policy, including our service providers and their data processing in the U.S., which may be accessible to U.S. law enforcement and national security authorities. We provide this personal and transaction information to Ford Motor Company of Canada, Limited to enable Ford to administer your transaction, provide you with requested services, improve automotive related products and services by conducting customer surveys, and provide you with marketing material which may be of interest to you, as permitted by applicable laws. For the Ford Privacy Policy (www.ford.ca) including use of service providers and U.S. data storage or if you do not want to receive marketing or survey materials from Ford please call 1-800-565-FORD (3673).