

S20-7  
MAY

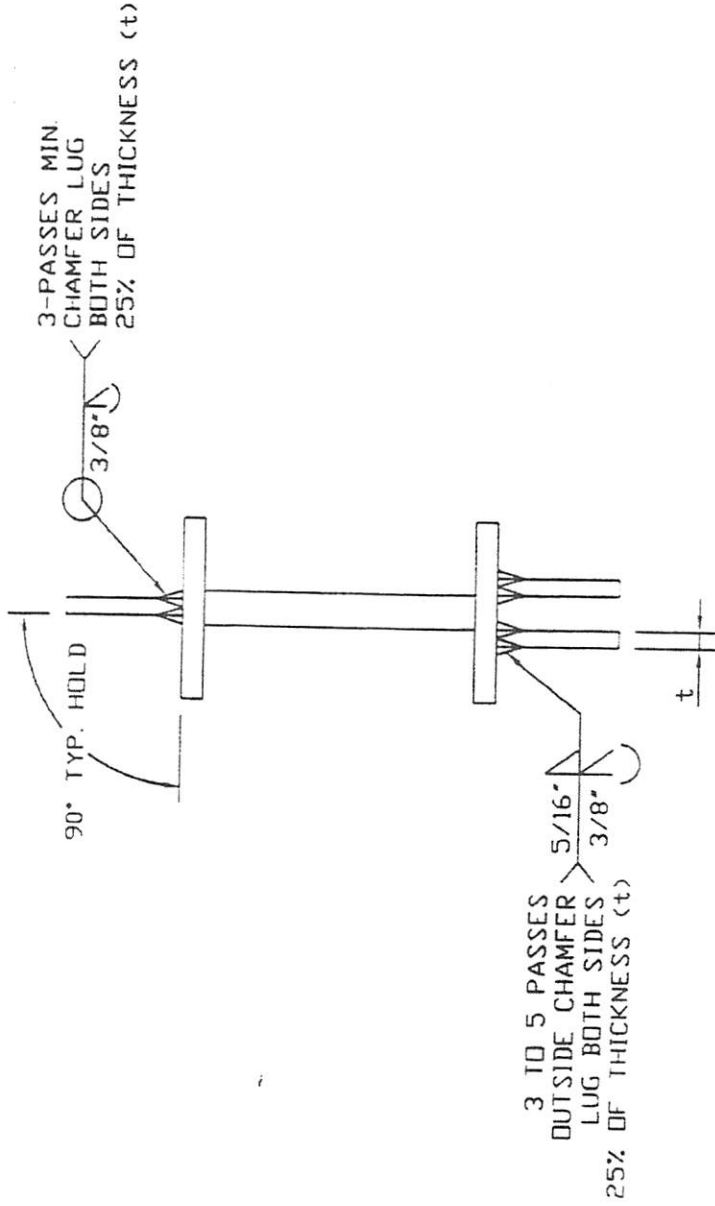

- NOTES:
1. TYPICAL LUG WELDING  
PRE-HEAT TO 225° F
  2. WELD (A) PARTS FIRST  
THEN (B) PART

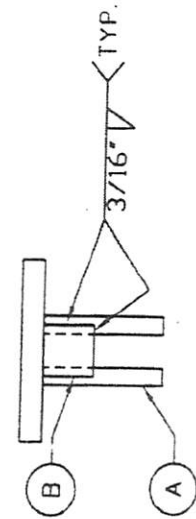

VIEW A-A

FONTAINE SPECIALIZED  
SPRINGVILLE, AL.

PART NAME: LUGS @ REAR		SCALE: 1 1/2" = 1"	SIZE: A	REVISION: 3
WELD REQUIREMENTS		PART NO.: A	80400003	
NEW ASSY:				

REV.#	DESCRIPTION CHANGE	DATE	BY	DATE	CHECKED	DATE	FRACTIONS	ANGLES	PLACES
2	REVISED WELD SYMBOLS	04/29/04	BEL	10/13/00	JIM	10/13/00	± 1/16"	± 0.5°	2 PLACE DEC.
1	ADDED NOTES AND VIEW A-A	04/02/01	JIM	UNLESS OTHERWISE SPECIFIED	JIM	04/02/01	± 0.03"	± 0.03°	3 PLACE DEC.

**CONTROLLED**

REV.	DESCRIPTION	BY	DATE
1	TOOK 1/16" FROM WIDTH	AMC	08/23/04

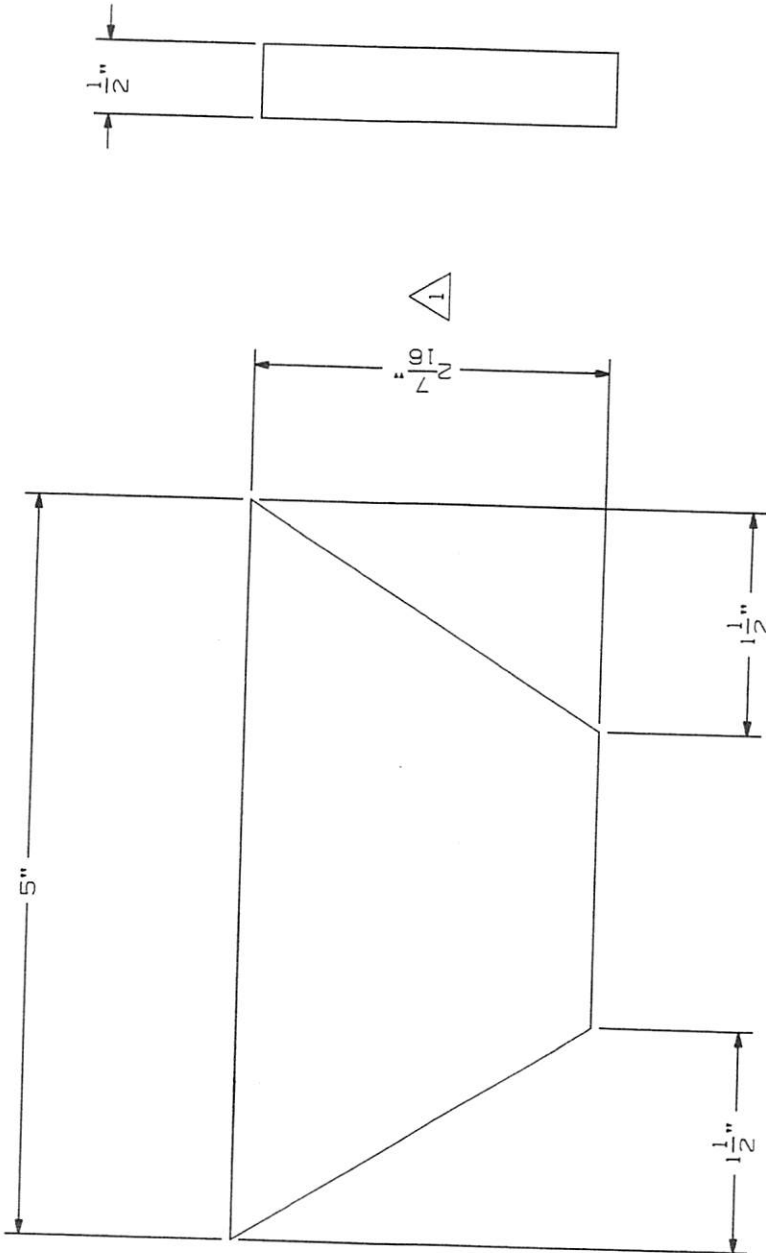

PART ATTRIBUTES	
THICKNESS:	.50
WIDTH:	2.44
LENGTH:	5.00
MAT. NO.:	420B4001
GRADE:	A514-100KSI
MATERIAL:	PLATE

TOLERANCES UNLESS OTHERWISE SPECIFIED		DATE	DATE	DATE	DATE	DATE	DATE
FRACTIONS	± 1/16"	07/16/03					
2 PLACE DEC.	± .03						
3 PLACE DEC.	± .005						
ANGLES	± 1°						
DRAWN: MZ		CHECKED:		APPROVED:		SCALE: 1/1	
PART NAME: BRACE		DATE:		DATE:		SHEET: 1 OF 1	
PART NUMBER: 72002B48		DATE:		DATE:		WEIGHT: 1.21	
DRAWING NUMBER: 79057434		DATE:		DATE:		REV.:	
DRAWING NUMBER: 79057434		DATE:		DATE:		REV.:	

**FONTAINE TRAILER CO.**  
 SPRINGVILLE, AL



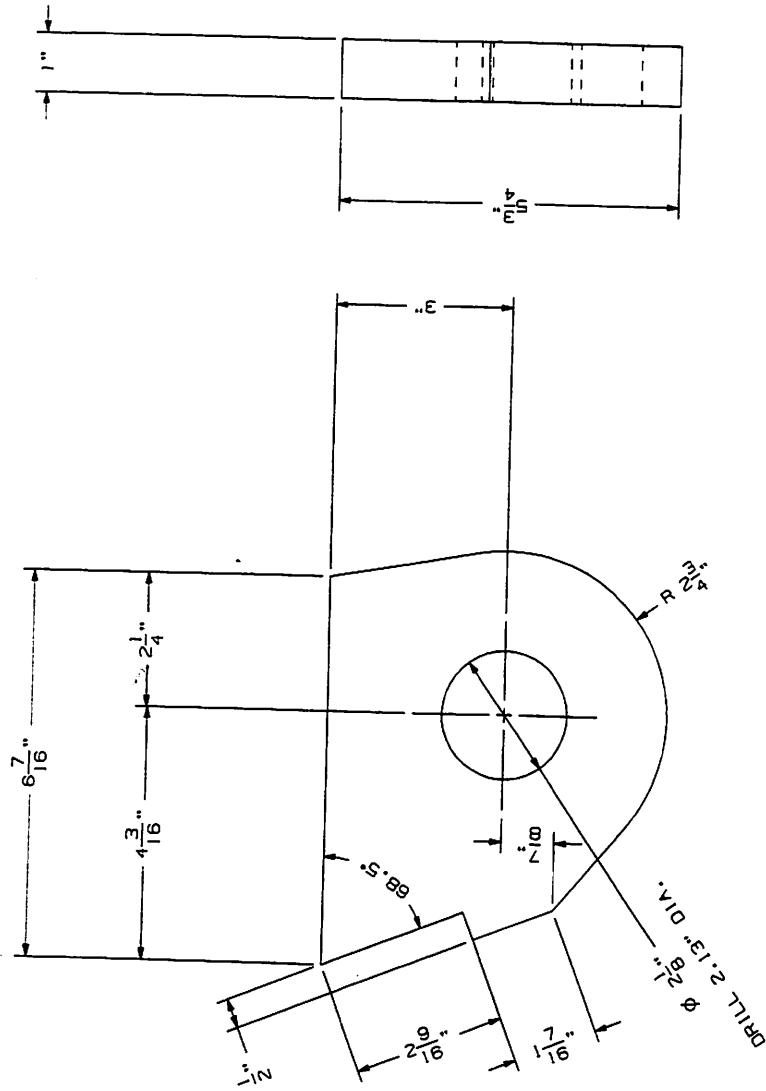

MATERIAL - T1 STEEL 100 KSI

THIS DRAWING AND THE INFORMATION IT CONTAINS IS THE PROPERTY OF FONTAINE TRAILER CO. IT IS TO BE KEPT IN CONFIDENTIALITY AND NOT REPRODUCED OR COPIED IN ANY MANNER WITHOUT THE WRITTEN PERMISSION OF FONTAINE TRAILER CO. IMMEDIATELY UPON DEMAND, AND THAT THE USER SHALL IN CONNECTION WITH WORK BEING DONE IN CONNECTION WITH FONTAINE TRAILER CO. BEING PERFORMED BY FONTAINE TRAILER CO.

DATE	7/28/15	DATE	
DRAWN	GD	CHECKED	
TOLERANCES UNLESS OTHERWISE SPECIFIED	FRACTIONS: 1/16"		
	2 PLACE DEC: 1/100		
	3 PLACE DEC: 1/1000		
	ANGLES: 1/16"		
REV.	DESCRIPTION	BY	DATE
1			
2			
3			
4			
5			
6			
7			
8			
9			
10			

DATE	7/28/15	DATE	
DRAWN	GD	CHECKED	
TOLERANCES UNLESS OTHERWISE SPECIFIED	FRACTIONS: 1/16"		
	2 PLACE DEC: 1/100		
	3 PLACE DEC: 1/1000		
	ANGLES: 1/16"		
REV.	DESCRIPTION	BY	DATE
1			
2			
3			
4			
5			
6			
7			
8			
9			
10			

DATE	7/28/15	DATE	
DRAWN	GD	CHECKED	
TOLERANCES UNLESS OTHERWISE SPECIFIED	FRACTIONS: 1/16"		
	2 PLACE DEC: 1/100		
	3 PLACE DEC: 1/1000		
	ANGLES: 1/16"		
REV.	DESCRIPTION	BY	DATE
1			
2			
3			
4			
5			
6			
7			
8			
9			
10			

DATE	7/28/15	DATE	
DRAWN	GD	CHECKED	
TOLERANCES UNLESS OTHERWISE SPECIFIED	FRACTIONS: 1/16"		
	2 PLACE DEC: 1/100		
	3 PLACE DEC: 1/1000		
	ANGLES: 1/16"		
REV.	DESCRIPTION	BY	DATE
1			
2			
3			
4			
5			
6			
7			
8			
9			
10			

DATE	7/28/15	DATE	
DRAWN	GD	CHECKED	
TOLERANCES UNLESS OTHERWISE SPECIFIED	FRACTIONS: 1/16"		
	2 PLACE DEC: 1/100		
	3 PLACE DEC: 1/1000		
	ANGLES: 1/16"		
REV.	DESCRIPTION	BY	DATE
1			
2			
3			
4			
5			
6			
7			
8			
9			
10			

DATE	7/28/15	DATE	
DRAWN	GD	CHECKED	
TOLERANCES UNLESS OTHERWISE SPECIFIED	FRACTIONS: 1/16"		
	2 PLACE DEC: 1/100		
	3 PLACE DEC: 1/1000		
	ANGLES: 1/16"		
REV.	DESCRIPTION	BY	DATE
1			
2			
3			
4			
5			
6			
7			
8			
9			
10			

DATE	7/28/15	DATE	
DRAWN	GD	CHECKED	
TOLERANCES UNLESS OTHERWISE SPECIFIED	FRACTIONS: 1/16"		
	2 PLACE DEC: 1/100		
	3 PLACE DEC: 1/1000		
	ANGLES: 1/16"		
REV.	DESCRIPTION	BY	DATE
1			
2			
3			
4			
5			
6			
7			
8			
9			
10			

DATE	7/28/15	DATE	
DRAWN	GD	CHECKED	
TOLERANCES UNLESS OTHERWISE SPECIFIED	FRACTIONS: 1/16"		
	2 PLACE DEC: 1/100		
	3 PLACE DEC: 1/1000		
	ANGLES: 1/16"		
REV.	DESCRIPTION	BY	DATE
1			
2			
3			
4			
5			
6			
7			
8			
9			
10			

DATE	7/28/15	DATE	
DRAWN	GD	CHECKED	
TOLERANCES UNLESS OTHERWISE SPECIFIED	FRACTIONS: 1/16"		
	2 PLACE DEC: 1/100		
	3 PLACE DEC: 1/1000		
	ANGLES: 1/16"		
REV.	DESCRIPTION	BY	DATE
1			
2			
3			
4			
5			
6			
7			
8			
9			
10			

DATE	7/28/15	DATE	
DRAWN	GD	CHECKED	
TOLERANCES UNLESS OTHERWISE SPECIFIED	FRACTIONS: 1/16"		
	2 PLACE DEC: 1/100		
	3 PLACE DEC: 1/1000		
	ANGLES: 1/16"		
REV.	DESCRIPTION	BY	DATE
1			
2			
3			
4			
5			
6			
7			
8			
9			
10			

DATE	7/28/15	DATE	
DRAWN	GD	CHECKED	
TOLERANCES UNLESS OTHERWISE SPECIFIED	FRACTIONS: 1/16"		
	2 PLACE DEC: 1/100		
	3 PLACE DEC: 1/1000		
	ANGLES: 1/16"		
REV.	DESCRIPTION	BY	DATE
1			
2			
3			
4			
5			
6			
7			
8			
9			
10			

DATE	7/28/15	DATE	
DRAWN	GD	CHECKED	
TOLERANCES UNLESS OTHERWISE SPECIFIED	FRACTIONS: 1/16"		
	2 PLACE DEC: 1/100		
	3 PLACE DEC: 1/1000		
	ANGLES: 1/16"		
REV.	DESCRIPTION	BY	DATE
1			
2			
3			
4			
5			
6			
7			
8			
9			
10			

DATE	7/28/15	DATE	
DRAWN	GD	CHECKED	
TOLERANCES UNLESS OTHERWISE SPECIFIED	FRACTIONS: 1/16"		
	2 PLACE DEC: 1/100		
	3 PLACE DEC: 1/1000		
	ANGLES: 1/16"		
REV.	DESCRIPTION	BY	DATE
1			
2			
3			
4			
5			
6			
7			
8			
9			
10			

DATE	7/28/15	DATE	
DRAWN	GD	CHECKED	
TOLERANCES UNLESS OTHERWISE SPECIFIED	FRACTIONS: 1/16"		
	2 PLACE DEC: 1/100		
	3 PLACE DEC: 1/1000		
	ANGLES: 1/16"		
REV.	DESCRIPTION	BY	DATE
1			
2			
3			
4			
5			
6			
7			
8			
9			
10			

DATE	7/28/15	DATE	
DRAWN	GD	CHECKED	
TOLERANCES UNLESS OTHERWISE SPECIFIED	FRACTIONS: 1/16"		
	2 PLACE DEC: 1/100		
	3 PLACE DEC: 1/1000		
	ANGLES: 1/16"		
REV.	DESCRIPTION	BY	DATE
1			
2			
3			
4			
5			
6			
7			
8			
9			
10			

DATE	7/28/15	DATE	
DRAWN	GD	CHECKED	
TOLERANCES UNLESS OTHERWISE SPECIFIED	FRACTIONS: 1/16"		
	2 PLACE DEC: 1/100		
	3 PLACE DEC: 1/1000		
	ANGLES: 1/16"		
REV.	DESCRIPTION	BY	DATE
1			
2			
3			
4			
5			
6			
7			
8			
9			
10			

DATE	7/28/15	DATE	
DRAWN	GD	CHECKED	
TOLERANCES UNLESS OTHERWISE SPECIFIED	FRACTIONS: 1/16"		
	2 PLACE DEC: 1/100		
	3 PLACE DEC: 1/1000		
	ANGLES: 1/16"		
REV.	DESCRIPTION	BY	DATE
1			
2			
3			
4			
5			
6			
7			
8			
9			
10			

DATE	7/28/15	DATE	
DRAWN	GD	CHECKED	
TOLERANCES UNLESS OTHERWISE SPECIFIED	FRACTIONS: 1/16"		
	2 PLACE DEC: 1/100		
	3 PLACE DEC: 1/1000		
	ANGLES: 1/16"		
REV.	DESCRIPTION	BY	DATE
1			
2			
3			
4			
5			
6			
7			
8			
9			
10			

DATE	7/28/15	DATE	
DRAWN	GD	CHECKED	
TOLERANCES UNLESS OTHERWISE SPECIFIED	FRACTIONS: 1/16"		
	2 PLACE DEC: 1/100		
	3 PLACE DEC: 1/1000		
	ANGLES: 1/16"		
REV.	DESCRIPTION	BY	DATE
1			
2			
3			
4			
5			
6			
7			
8			
9			
10			

DATE	7/28/15	DATE	
DRAWN	GD	CHECKED	
TOLERANCES UNLESS OTHERWISE SPECIFIED	FRACTIONS: 1/16"		
	2 PLACE DEC: 1/100		
	3 PLACE DEC: 1/1000		
	ANGLES: 1/16"		
REV.	DESCRIPTION	BY	DATE
1			
2			
3			
4			
5			
6			
7			
8			
9			
10			

DATE	7/28/15	DATE	
DRAWN	GD	CHECKED	
TOLERANCES UNLESS OTHERWISE SPECIFIED	FRACTIONS: 1/16"		
	2 PLACE DEC: 1/100		
	3 PLACE DEC: 1/1000		
	ANGLES: 1/16"		
REV.	DESCRIPTION	BY	DATE
1			
2			
3			
4			
5			
6			
7			

CONTRACT NO. AND THE INFORMATION IN THIS DRAWING IS TO BE USED FOR THE DESIGN AND CONSTRUCTION OF THE PROJECT ONLY. THE USER SHALL BE RESPONSIBLE FOR OBTAINING ALL NECESSARY PERMITS AND REGULATIONS. THE USER SHALL BE RESPONSIBLE FOR OBTAINING ALL NECESSARY PERMITS AND REGULATIONS. THE USER SHALL BE RESPONSIBLE FOR OBTAINING ALL NECESSARY PERMITS AND REGULATIONS.

1. ASTM A5 TABLES TO 31 TOLERANCES FOR STEEL PLATBARS, PLATES, SHAPES  
 2. ASTM A29 TABLES A1.11 TO A1.14 TOLERANCES FOR STEEL COLD FINISHED BARS  
 3. AISC ASD 9TH EDITION PAGE 3-155 STD MILL PRACTICE FOR STEEL PIPE & TUBING

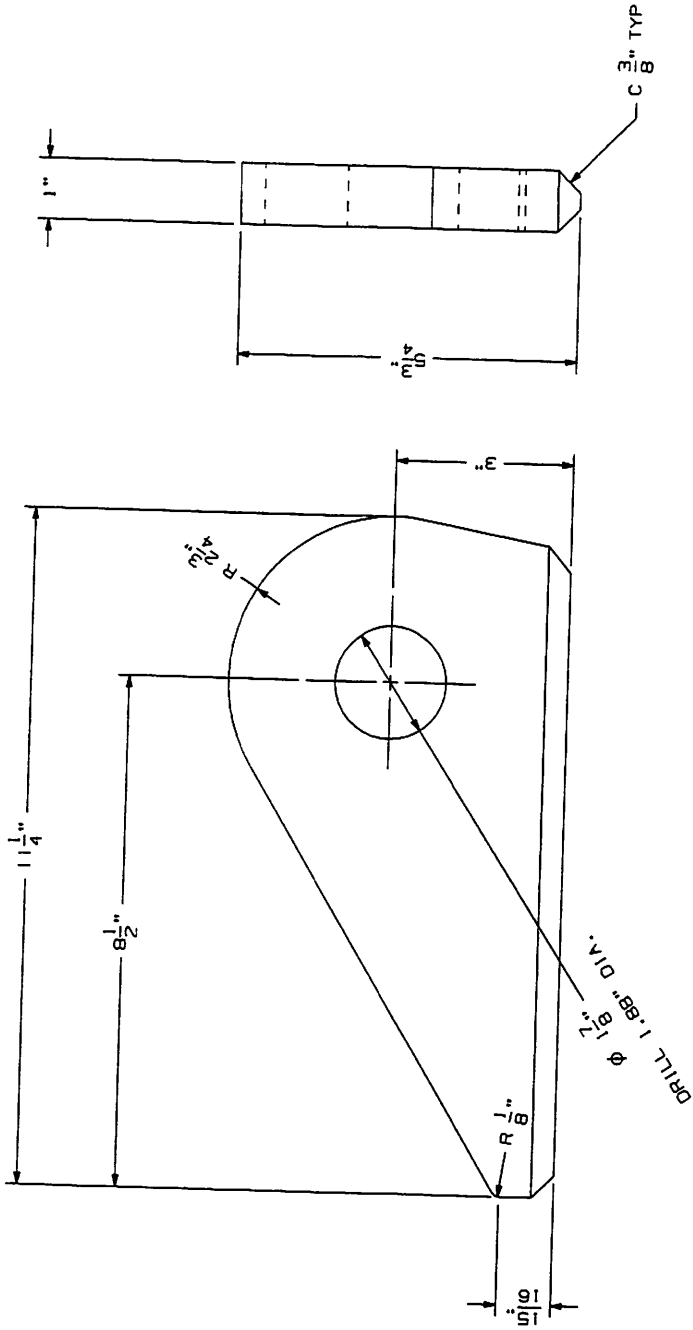

DATE	7/28/15	DATE	7/28/15	DATE	7/28/15
DESIGNED	CS	DRAWN	CS	CHECKED	CS
APPROVED		APPROVED		APPROVED	
TOLERANCES UNLESS OTHERWISE SPECIFIED			TOLERANCES UNLESS OTHERWISE SPECIFIED		
FRACTIONS: ± 1/16"			FRACTIONS: ± 1/16"		
3 PLACE DEC: ± .005			3 PLACE DEC: ± .005		
ANGLES: ± 1'			ANGLES: ± 1'		
REV.	DESCRIPTION	BY	DATE	REV.	DESCRIPTION
0				0	

DATE	7/28/15	DATE	7/28/15	DATE	7/28/15
DESIGNED	CS	DRAWN	CS	CHECKED	CS
APPROVED		APPROVED		APPROVED	
TOLERANCES UNLESS OTHERWISE SPECIFIED			TOLERANCES UNLESS OTHERWISE SPECIFIED		
FRACTIONS: ± 1/16"			FRACTIONS: ± 1/16"		
3 PLACE DEC: ± .005			3 PLACE DEC: ± .005		
ANGLES: ± 1'			ANGLES: ± 1'		
REV.	DESCRIPTION	BY	DATE	REV.	DESCRIPTION
0				0	

GRADE:	100
MATERIAL:	PLATE
FONTAINE TRAILER CO.	SPRINGVILLE HEAVY HAUL
TOP LUG	
79000717	0