

## PBS Vehicle Approval

Heavy Vehicle National Law Section 23

Heavy Vehicle (General) National Regulation Section 17

**IMPORTANT**

- This combination must be operated under a Notice or an access permit unless compliant with the Specified PBS Vehicle provision.
- The driver must carry a copy of this PBS Vehicle Approval and an associated access permit or notice and be able to produce readable copies (electronic or hard copy) if requested by Authorised Officers.
- All vehicle units in a combination (prime movers, trailers, dollies, etc.) must be listed on this VA.
- The driver must be able to identify the specific combination being driven within the VA.
- Failure to comply with the above can incur penalties for the operator, driver, or other responsible parties.

9 February 2026

**Ref No: PBS – VA22459 – V210903 – v1A**

This PBS Vehicle Approval modifies any previously issued approval for the vehicles listed herein operating under Application Number V210903 and is a modification of VA18987.

Design Approval Holder	Ben Paganoni B&L Dirtworks	Address	2315 Ballarto Rd Cardinia VIC 3978
------------------------	-------------------------------	---------	---------------------------------------

Application Number	V210903	Vehicle	3-axle truck 4-axle dog
Load	Quarry and Bulk; Waste	Length (mm)	≤ 20260
Assessor	Marcus Coleman	Height (mm)	≤ 4300

### Combination Matrix

For each Truck and Trailer, the corresponding drawing reference number, dimension set number and mass table numbers are listed below. The dimension set number e.g., ‘Variant 1’ indicates the maximum allowable payload heights and/or allowable tyre options for the corresponding Truck and Trailer - refer to the Operating Conditions and Approved Tyre Options sections on this VA.

New VINs added in this VA are listed in bold.

Truck 2	Make	GCM (t)	Truck 4	Make	GCM (t)
6F5000000HA457942	KW	97	6F5000000HA460306	KW	97

<b>Truck 5</b>	<b>Make</b>	<b>GCM (t)</b>	Truck 6	Make	GCM (t)
<b>6F5000000JA462964</b>	<b>KW</b>	<b>97</b>	6F5000000MA469592	KW	97

Truck 7	Make	GCM (t)	Truck 8	Make	GCM (t)
6F5000000MA470195	KW	70	6F5000000GA455926	KW	97

Truck 9	Make	GCM (t)	Truck 10	Make	GCM (t)
6F5000000GA457701	KW	97	6F5000000MA473253	KW	97

Truck 11	Make	GCM (t)	Truck 12	Make	GCM (t)
6F5000000HA459529	KW	70	6F5000000HA460760	KW	70

Truck 13	Make	GCM (t)	Truck 14	Make	GCM (t)
6F5000000NA482001	KW	97	6F5000000PA477572	KW	97

Truck 15	Make	GCM (t)	Truck 16	Make	GCM (t)
6F5000000PA486416	KW	97	6F5000000KA465304	KW	97

Truck 17	Make	GCM (t)	Truck 18	Make	GCM (t)
6F5000000HA457990	KW	97	6F5000000RA488269 6F5000000RA488270	KW	97

Trailer 2	ATM (t)	Trailer 3	ATM (t)	Trailer 4	ATM (t)
6T9T24V86H0AHH153	35	6T9T24V86J0AFH069	35	6T9T24V86G0AFH153	35

Trailer 5	ATM (t)	Trailer 6	ATM (t)	Trailer 7	ATM (t)
6HUMTAHXW5H000040	33	6T9T24V97D0AFH070	35	6B9TR4D0GGSCB8235	34

Trailer 8	ATM (t)	Trailer 9	ATM (t)	Trailer 10	ATM (t)
6B9TR4D0GHSCB8350	35	6T9T24V86NAAFH029	35	6F80000000B092853	34

Trailer 11	ATM (t)	Trailer 12	ATM (t)	Trailer 13	ATM (t)
6T9T24V86J0AFH020	35	6T9T24V86PAAFH046	35	6T9T24V86PAAFH055	35

Trailer 14	ATM (t)	Trailer 15	ATM (t)	Trailer 16	ATM (t)
6T9T24V86PAAFH103	35	6T9T24V86RA5TH091 6T9T24V86RA5TH093	34	6T9T24V86RAAFH042 6T9T24V86RAAFH043	35

Trailer 17	ATM (t)
6T9T24V86SAAFH091	35

	Trailer 2	Trailer 3	Trailer 4	Trailer 5	Trailer 6	Trailer 7
Truck 2	NA	NA	NA	NA	NA	NA
Truck 4	B&L01_003 Variant 1 Table 31	NA	NA	NA	NA	NA
Truck 5	NA	10571 Variant 1 Table 31	NA	NA	NA	NA
Truck 6	NA	NA	B&L01_009 Variant 1 Table 31	NA	NA	NA
Truck 7	NA	NA	NA	B&L01_011 Variant 1 Table 33	NA	NA
Truck 8	NA	NA	NA	NA	B&L01_012 Variant 1 Table 29	NA
Truck 9	NA	NA	NA	NA	NA	B&L01_013 Variant 2 Table 10, 35
Truck 10	NA	NA	NA	NA	NA	NA
Truck 11	NA	NA	NA	NA	NA	NA
Truck 12	NA	NA	NA	NA	NA	NA
Truck 13	NA	NA	NA	NA	NA	NA
Truck 14	NA	NA	NA	NA	NA	NA
Truck 15	DRC_002 Variant 2 Table 7, 31	DRC_002 Variant 2 Table 7, 31	NA	DRC_002 Variant 2 Table 6, 33	DRC_002 Variant 2 Table 17, 29	DRC_002 Variant 2 Table 19, 35
Truck 16	DRC_005 Variant 2 Table 6, 40	DRC_005 Variant 2 Table 6, 40	NA	DRC_005 Variant 2 Table 4, 33	DRC_005 Variant 2 Table 20, 29	DRC_005 Variant 2 Table 11, 35
Truck 17	DRC_006 Variant 2 Table 2, 40	DRC_006 Variant 2 Table 2, 40	NA	DRC_006 Variant 2 Table 24, 33	DRC_006 Variant 2 Table 25, 29	DRC_006 Variant 2 Table 26, 35
Truck 18	DRC_007 Variant 2 Table 9, 31	DRC_007 Variant 2 Table 9, 31	NA	DRC_007 Variant 2 Table 19, 33	DRC_007 Variant 2 Table 13, 29	DRC_007 Variant 2 Table 1, 35

	Trailer 8	Trailer 9	Trailer 10	Trailer 11	Trailer 12
Truck 2	B&L01_014 Variant 2 Table 1, 28	NA	NA	NA	NA
Truck 4	NA	NA	NA	NA	NA
Truck 5	NA	NA	NA	NA	NA
Truck 6	NA	NA	NA	NA	NA
Truck 7	NA	NA	NA	NA	NA
Truck 8	NA	NA	NA	NA	NA
Truck 9	NA	NA	NA	NA	NA
Truck 10	NA	11492/11493 Variant 2 Table 12, 29	NA	NA	NA
Truck 11	NA	NA	B&L01_015 Variant 2 Table 8, 38	NA	NA
Truck 12	NA	NA	NA	10524 Variant 2 Table 11, 29	NA
Truck 13	NA	NA	NA	NA	11917 Variant 2 Table 12, 39
Truck 14	NA	NA	NA	NA	NA
Truck 15	DRC_002 Variant 2 Table 13, 28	DRC_002 Variant 2 Table 12, 29	DRC_002 Variant 2 Table 7, 38	DRC_002 Variant 2 Table 13, 29	DRC_002 Variant 2 Table 3, 39
Truck 16	DRC_005 Variant 2 Table 21, 28	DRC_005 Variant 2 Table 22, 29	DRC_005 Variant 2 Table 6, 38	DRC_005 Variant 2 Table 21, 29	DRC_005 Variant 2 Table 13, 29
Truck 17	DRC_006 Variant 2 Table 15, 28	DRC_006 Variant 2 Table 23, 29	DRC_006 Variant 2 Table 2, 38	DRC_006 Variant 2 Table 15, 29	DRC_006 Variant 2 Table 5, 29
Truck 18	DRC_007 Variant 2 Table 23, 28	DRC_007 Variant 2 Table 17, 29	DRC_007 Variant 2 Table 9, 38	DRC_007 Variant 2 Table 23, 29	DRC_007 Variant 2 Table 14, 39

	Trailer 13	Trailer 14	Trailer 15	Trailer 16	Trailer 17
Truck 2	NA	DRC_003 Variant 2 Table 1, 29	DRC_004 Variant 2 Table 2, 30	DRC_008 Variant 2 Table 16, 29	DRC_009 Variant 2 Table 1, 29
Truck 4	NA	DRC_003 Variant 2 Table 3, 29	DRC_004 Variant 2 Table 4, 30	DRC_008 Variant 2 Table 17, 29	DRC_009 Variant 2 Table 3, 29
Truck 5	NA	DRC_003 Variant 2 Table 5, 29	DRC_004 Variant 2 Table 6, 30	DRC_008 Variant 2 Table 25, 29	DRC_009 Variant 2 Table 4, 29
Truck 6	NA	DRC_003 Variant 2 Table 7, 29	DRC_004 Variant 2 Table 8, 32	DRC_008 Variant 2 Table 6, 29	DRC_009 Variant 2 Table 9, 29
Truck 7	NA	DRC_003 Variant 2 Table 9, 29	DRC_004 Variant 2 Table 10, 30	DRC_008 Variant 2 Table 19, 29	DRC_009 Variant 2 Table 9, 29
Truck 8	NA	DRC_003 Variant 2 Table 11, 29	DRC_004 Variant 2 Table 1, 34	DRC_008 Variant 2 Table 14, 29	DRC_009 Variant 2 Table 16, 29
Truck 9	NA	DRC_003 Variant 2 Table 11, 36	DRC_004 Variant 2 Table 1, 37	DRC_008 Variant 2 Table 14, 29	DRC_009 Variant 2 Table 16, 39
Truck 10	NA	DRC_003 Variant 2 Table 13, 29	DRC_004 Variant 2 Table 14, 30	DRC_008 Variant 2 Table 21, 29	DRC_009 Variant 2 Table 13, 29
Truck 11	NA	DRC_003 Variant 2 Table 15, 29	DRC_004 Variant 2 Table 16, 29	DRC_008 Variant 2 Table 23, 29	DRC_009 Variant 2 Table 14, 29
Truck 12	NA	DRC_003 Variant 2 Table 11, 29	DRC_004 Variant 2 Table 1, 30	DRC_008 Variant 2 Table 14, 29	DRC_009 Variant 2 Table 16, 29
Truck 13	NA	NA	DRC_004 Variant 2 Table 17, 30	DRC_008 Variant 2 Table 24, 29	DRC_009 Variant 2 Table 20, 29
Truck 14	11834/11835 Variant 2 Table 7, 29	DRC_003 Variant 2 Table 9, 29	DRC_004 Variant 2 Table 18, 30	DRC_008 Variant 2 Table 1, 29	DRC_009 Variant 2 Table 27, 29
Truck 15	DRC_002 Variant 2 Table 12, 29	DRC_002 Variant 2 Table 13, 29	DRC_004 Variant 2 Table 14, 30	DRC_008 Variant 2 Table 21, 29	DRC_009 Variant 2 Table 13, 29
Truck 16	DRC_005 Variant 2 Table 22, 29	DRC_005 Variant 2 Table 21, 29	DRC_004 Variant 2 Table 23, 36	DRC_008 Variant 2 Table 28, 41	DRC_009 Variant 2 Table 21, 29
Truck 17	DRC_006 Variant 2 Table 23, 29	DRC_006 Variant 2 Table 25, 29	DRC_004 Variant 2 Table 11, 36	DRC_008 Variant 2 Table 13, 29	DRC_009 Variant 2 Table 15, 29
Truck 18	DRC_007 Variant 2 Table 17, 29	DRC_007 Variant 2 Table 23, 29	DRC_007 Variant 2 Table 5, 30	DRC_008 Variant 2 Table 12, 29	DRC_009 Variant 2 Table 23, 29

**Table 1**  
**Truck 2 and Trailer 8, 14, 17**  
**Truck 8, 12 and Trailer 15**  
**Truck 9 and Trailer 15**  
**Truck 14 and Trailer 16**  
**Truck 18 and Trailer 7**

Mass Limits	Level 1		Axle Group Masses	Level 1
				GML
GML (t)	50.5		Steer (t)	6.5
CML (t)	NA		Drive (t)	16.5
HML (t)	NA		Trailer Front (t)	15.0
Bridge Assessment	Tier 1		Trailer Rear (t)	15.0
The mass across axle groups is limited to -				
			Axle Groups	GML
			2 to 4	44.10
			3 to 4	27.60

**Table 2**  
**Truck 2 and Trailer 15**  
**Truck 17 and Trailer 2, 3, 10**

Mass Limits	Level 1		Axle Group Masses	Level 1
				GML
GML (t)	50.4		Steer (t)	6.5
CML (t)	NA		Drive (t)	16.5
HML (t)	NA		Trailer Front (t)	15.0
Bridge Assessment	Tier 1		Trailer Rear (t)	15.0
The mass across axle groups is limited to -				
			Axle Groups	GML
			2 to 4	43.90
			3 to 4	27.40

**Table 3**  
**Truck 4 and Trailer 14, 17**  
**Truck 15 and Trailer 12**

Mass Limits	Level 1		Axle Group Masses	Level 1
				GML
GML (t)	50.5		Steer (t)	6.5
CML (t)	NA		Drive (t)	16.5
HML (t)	NA		Trailer Front (t)	15.0
Bridge Assessment	Tier 1		Trailer Rear (t)	15.0
The mass across axle groups is limited to -				
			Axle Groups	GML
			2 to 4	44.55
			3 to 4	28.05

**Table 4**  
**Truck 4 and Trailer 15**  
**Truck 5 and Trailer 17**  
**Truck 16 and Trailer 5**

Mass Limits	Level 1		Axle Group Masses	Level 1
				GML
GML (t)	50.5		Steer (t)	6.5
CML (t)	NA		Drive (t)	16.5
HML (t)	NA		Trailer Front (t)	15.0
Bridge Assessment	Tier 1		Trailer Rear (t)	15.0
The mass across axle groups is limited to -				
			Axle Groups	GML
			2 to 4	44.35
			3 to 4	27.85

**Table 5**  
**Truck 5 and Trailer 14**  
**Truck 17 and Trailer 12**  
**Truck 18 and Trailer 15**

Mass Limits	Level 1		Axle Group Masses	Level 1
				GML
GML (t)	50.5		Steer (t)	6.5
CML (t)	NA		Drive (t)	16.5
HML (t)	NA		Trailer Front (t)	15.0
Bridge Assessment	Tier 1		Trailer Rear (t)	15.0
The mass across axle groups is limited to -				
			Axle Groups	GML
			2 to 4	44.40
			3 to 4	27.90

**Table 6**  
**Truck 5 and Trailer 15**  
**Truck 6 and Trailer 16**  
**Truck 15 and Trailer 5**  
**Truck 16 and Trailer 2, 3, 10**

Mass Limits	Level 1		Axle Group Masses	Level 1
				GML
GML (t)	50.5		Steer (t)	6.5
CML (t)	NA		Drive (t)	16.5
HML (t)	NA		Trailer Front (t)	15.0
Bridge Assessment	Tier 1		Trailer Rear (t)	15.0
The mass across axle groups is limited to -				
			Axle Groups	GML
			2 to 4	44.20
			3 to 4	27.70

**Table 7**  
**Truck 6 and Trailer 14**  
**Truck 14 and Trailer 13**  
**Truck 15 and Trailer 2, 3, 10**

Mass Limits	Level 1		Axle Group Masses	Level 1
				GML
GML (t)	50.5		Steer (t)	6.5
CML (t)	NA		Drive (t)	16.5
HML (t)	NA		Trailer Front (t)	15.0
Bridge Assessment	Tier 1		Trailer Rear (t)	15.0
The mass across axle groups is limited to -				
			Axle Groups	GML
			2 to 4	44.05
			3 to 4	27.55

**Table 8**  
**Truck 6 and Trailer 15**  
**Truck 11 and Trailer 10**

Mass Limits	Level 1		Axle Group Masses	Level 1
				GML
GML (t)	50.35		Steer (t)	6.5
CML (t)	NA		Drive (t)	16.5
HML (t)	NA		Trailer Front (t)	15.0
Bridge Assessment	Tier 1		Trailer Rear (t)	15.0
The mass across axle groups is limited to -				
			Axle Groups	GML
			2 to 4	43.85
			3 to 4	27.35

**Table 9**  
**Truck 6 and Trailer 17**  
**Truck 7 and Trailer 14, 17**  
**Truck 14 and Trailer 14**  
**Truck 18 and Trailer 2, 3, 10**

Mass Limits	Level 1		Axle Group Masses	Level 1
				GML
GML (t)	50.5		Steer (t)	6.5
CML (t)	NA		Drive (t)	16.5
HML (t)	NA		Trailer Front (t)	15.0
Bridge Assessment	Tier 1		Trailer Rear (t)	15.0
The mass across axle groups is limited to -				
			Axle Groups	GML
			2 to 4	44.00
			3 to 4	27.50

**Table 10**  
**Truck 7 and Trailer 15**  
**Truck 9 and Trailer 7**

Mass Limits	Level 1		Axle Group Masses	Level 1
				GML
GML (t)	50.3		Steer (t)	6.5
CML (t)	NA		Drive (t)	16.5
HML (t)	NA		Trailer Front (t)	15.0
Bridge Assessment	Tier 1		Trailer Rear (t)	15.0
The mass across axle groups is limited to -				
			Axle Groups	GML
			2 to 4	43.80
			3 to 4	27.30

**Table 11**  
**Truck 8 and Trailer 14**  
**Truck 12 and Trailer 11, 14**  
**Truck 9 and Trailer 14**  
**Truck 17 and Trailer 15**  
**Truck 16 and Trailer 7**

Mass Limits	Level 1		Axle Group Masses	Level 1
				GML
GML (t)	50.5		Steer (t)	6.5
CML (t)	NA		Drive (t)	16.5
HML (t)	NA		Trailer Front (t)	15.0
Bridge Assessment	Tier 1		Trailer Rear (t)	15.0
The mass across axle groups is limited to -				
			Axle Groups	GML
			2 to 4	44.30
			3 to 4	27.80

**Table 12**  
**Truck 10 and Trailer 9**  
**Truck 15 and Trailer 9, 13**  
**Truck 13 and Trailer 12**  
**Truck 18 and Trailer 16**

Mass Limits	Level 1		Axle Group Masses	Level 1
				GML
GML (t)	50.5		Steer (t)	6.5
CML (t)	NA		Drive (t)	16.5
HML (t)	NA		Trailer Front (t)	15.0
Bridge Assessment	Tier 1		Trailer Rear (t)	15.0
The mass across axle groups is limited to -				
			Axle Groups	GML
			2 to 4	44.75
			3 to 4	28.25

**Table 13**  
**Truck 10 and Trailer 14, 17**  
**Truck 15 and Trailer 8, 11, 14, 17**  
**Truck 16 and Trailer 12**  
**Truck 17 and Trailer 16**  
**Truck 18 and Trailer 6**

Mass Limits	Level 1		Axle Group Masses	Level 1
				GML
GML (t)	50.5		Steer (t)	6.5
CML (t)	NA		Drive (t)	16.5
HML (t)	NA		Trailer Front (t)	15.0
Bridge Assessment	Tier 1		Trailer Rear (t)	15.0
The mass across axle groups is limited to -				
			Axle Groups	GML
			2 to 4	44.65
			3 to 4	28.15

**Table 14**  
**Truck 8, 9, 12 and Trailer 16**  
**Truck 10, 15 and Trailer 15**  
**Truck 11 and Trailer 17**  
**Truck 18 and Trailer 12**

Mass Limits	Level 1		Axle Group Masses	Level 1
				GML
GML (t)	50.5		Steer (t)	6.5
CML (t)	NA		Drive (t)	16.5
HML (t)	NA		Trailer Front (t)	15.0
Bridge Assessment	Tier 1		Trailer Rear (t)	15.0
The mass across axle groups is limited to -				
			Axle Groups	GML
			2 to 4	44.45
			3 to 4	27.95

**Table 15**  
**Truck 11 and Trailer 14**  
**Truck 17 and Trailer 8, 11, 17**

Mass Limits	Level 1		Axle Group Masses	Level 1
				GML
GML (t)	50.5		Steer (t)	6.5
CML (t)	NA		Drive (t)	16.5
HML (t)	NA		Trailer Front (t)	15.0
Bridge Assessment	Tier 1		Trailer Rear (t)	15.0
The mass across axle groups is limited to -				
			Axle Groups	GML
			2 to 4	44.50
			3 to 4	28.00

**Table 16**  
**Truck 2 and Trailer 16**  
**Truck 8, 9 and Trailer 17**  
**Truck 11 and Trailer 15**  
**Truck 12 and Trailer 17**

Mass Limits	Level 1		Axle Group Masses	Level 1
				GML
GML (t)	50.5		Steer (t)	6.5
CML (t)	NA		Drive (t)	16.5
HML (t)	NA		Trailer Front (t)	15.0
Bridge Assessment	Tier 1		Trailer Rear (t)	15.0
The mass across axle groups is limited to -				
			Axle Groups	GML
			2 to 4	44.25
			3 to 4	27.75

**Table 17**  
**Truck 4 and Trailer 16**  
**Truck 13 and Trailer 15**  
**Truck 15 and Trailer 6**  
**Truck 18 and Trailer 9, 13**

Mass Limits	Level 1		Axle Group Masses	Level 1
				GML
GML (t)	50.5		Steer (t)	6.5
CML (t)	NA		Drive (t)	16.5
HML (t)	NA		Trailer Front (t)	15.0
Bridge Assessment	Tier 1		Trailer Rear (t)	15.0
The mass across axle groups is limited to -				
			Axle Groups	GML
			2 to 4	44.70
			3 to 4	28.20

**Table 18**  
**Truck 14 and Trailer 15**

Mass Limits	Level 1		Axle Group Masses	Level 1
				GML
GML (t)	50.25		Steer (t)	6.5
CML (t)	NA		Drive (t)	16.5
HML (t)	NA		Trailer Front (t)	15.0
Bridge Assessment	Tier 1		Trailer Rear (t)	15.0
The mass across axle groups is limited to -				
			Axle Groups	GML
			2 to 4	43.75
			3 to 4	27.25

**Table 19**  
**Truck 7 and Trailer 16**  
**Truck 15 and Trailer 7**  
**Truck 18 and Trailer 5**

Mass Limits	Level 1		Axle Group Masses	Level 1
				GML
GML (t)	50.5		Steer (t)	6.5
CML (t)	NA		Drive (t)	16.5
HML (t)	NA		Trailer Front (t)	15.0
Bridge Assessment	Tier 1		Trailer Rear (t)	15.0
The mass across axle groups is limited to -				
			Axle Groups	GML
			2 to 4	44.15
			3 to 4	27.65

**Table 20**  
**Truck 16 and Trailer 6**  
**Truck 13 and Trailer 17**

Mass Limits	Level 1		Axle Group Masses	Level 1
				GML
GML (t)	50.5		Steer (t)	6.5
CML (t)	NA		Drive (t)	16.5
HML (t)	NA		Trailer Front (t)	15.0
Bridge Assessment	Tier 1		Trailer Rear (t)	15.0
The mass across axle groups is limited to -				
			Axle Groups	GML
			2 to 4	44.85
			3 to 4	28.35

**Table 21**  
**Truck 10, 15 and Trailer 16**  
**Truck 10, 15, 16 and Trailer 8, 11**  
**Truck 16 and Trailer 14, 17**

Mass Limits	Level 1		Axle Group Masses	Level 1
				GML
GML (t)	50.5		Steer (t)	6.5
CML (t)	NA		Drive (t)	16.5
HML (t)	NA		Trailer Front (t)	15.0
Bridge Assessment	Tier 1		Trailer Rear (t)	15.0
The mass across axle groups is limited to -				
			Axle Groups	GML
			2 to 4	44.80
			3 to 4	28.30

**Table 22**  
**Truck 16 and Trailer 9, 13**

Mass Limits	Level 1		Axle Group Masses	Level 1
				GML
GML (t)	50.5		Steer (t)	6.5
CML (t)	NA		Drive (t)	16.5
HML (t)	NA		Trailer Front (t)	15.0
Bridge Assessment	Tier 1		Trailer Rear (t)	15.0
The mass across axle groups is limited to -				
			Axle Groups	GML
			2 to 4	44.90
			3 to 4	28.40

**Table 23**  
**Truck 11 and Trailer 16**  
**Truck 16 and Trailer 15**  
**Truck 17 and Trailer 9, 13**  
**Truck 18 and Trailer 8, 11, 14, 17**

Mass Limits	Level 1		Axle Group Masses	Level 1
				GML
GML (t)	50.5		Steer (t)	6.5
CML (t)	NA		Drive (t)	16.5
HML (t)	NA		Trailer Front (t)	15.0
Bridge Assessment	Tier 1		Trailer Rear (t)	15.0
The mass across axle groups is limited to -				
			Axle Groups	GML
			2 to 4	44.60
			3 to 4	28.10

**Table 24**  
**Truck 13 and Trailer 16**  
**Truck 17 and Trailer 5**

Mass Limits	Level 1		Axle Group Masses	Level 1
				GML
GML (t)	50.5		Steer (t)	6.5
CML (t)	NA		Drive (t)	16.5
HML (t)	NA		Trailer Front (t)	15.0
Bridge Assessment	Tier 1		Trailer Rear (t)	15.0
The mass across axle groups is limited to -				
			Axle Groups	GML
			2 to 4	44.05
			3 to 4	27.55

**Table 25**  
**Truck 5 and Trailer 16**  
**Truck 17 and Trailer 6, 14**

Mass Limits	Level 1		Axle Group Masses	Level 1
				GML
GML (t)	50.5		Steer (t)	6.5
CML (t)	NA		Drive (t)	16.5
HML (t)	NA		Trailer Front (t)	15.0
Bridge Assessment	Tier 1		Trailer Rear (t)	15.0
The mass across axle groups is limited to -				
			Axle Groups	GML
			2 to 4	44.55
			3 to 4	28.05

**Table 26**  
**Truck 17 and Trailer 7**

Mass Limits	Level 1		Axle Group Masses	Level 1
				GML
GML (t)	50.5		Steer (t)	6.5
CML (t)	NA		Drive (t)	16.5
HML (t)	NA		Trailer Front (t)	15.0
Bridge Assessment	Tier 1		Trailer Rear (t)	15.0
The mass across axle groups is limited to -				
			Axle Groups	GML
			2 to 4	44.00
			3 to 4	27.50

**Table 27**  
**Truck 14 and Trailer 17**

Mass Limits	Level 1	Axle Group Masses	Level 1	
			GML	
GML (t)	50.45	Steer (t)	6.5	
CML (t)	NA	Drive (t)	16.5	
HML (t)	NA	Trailer Front (t)	15.0	
Bridge Assessment	Tier 1	Trailer Rear (t)	15.0	
The mass across axle groups is limited to -				
Axle Groups			GML	
2 to 4			43.95	
3 to 4			27.45	

**Table 28**  
**Truck 2, 15, 16, 17 and Trailer 8**  
**Truck 18 and Trailer 8**

Mass Limits	Level 2	Axle Group Masses	Level 2		
			GML	CML	HML
GML (t)	54.5	Steer (t)	6.5	6.5	6.5
CML (t)	55.5	Drive (t)	16.5	17.0	17.0
HML (t)	56.0	Trailer Front (t)	16.5	17.0	17.0
Bridge Assessment	Tier 1	Trailer Rear (t)	16.5	17.0	17.0
The mass across axle groups is limited to -					
Axle Groups			GML	CML	HML
3 to 4			31.50	32.50	32.50

**Table 29**

Truck 2, 4, 5, 6, 7 and Trailer 14, 17  
 Truck 8 and Trailer 6, 14, 17  
 Truck 10 and Trailer 9, 14, 17  
 Truck 11 and Trailer 14, 15, 17  
 Truck 12 and Trailer 11, 14, 17  
 Truck 14 and Trailer 13, 14, 17  
 Truck 15 and Trailer 6, 9, 11, 13, 14, 17  
 Truck 16, 17 and Trailer 6, 9, 11, 12, 13, 14, 17  
 Truck 2, 4, 5, 6, 7, 8, 9, 10, 11, 12, 13, 14, 15, 16, 17 and Trailer 16  
 Truck 18 and Trailer 6, 9, 11, 13, 14, 17

Mass Limits	Level 2	Axle Group Masses	Level 2		
			GML	CML	HML
GML (t)	56.0	Steer (t)	6.5	6.5	6.5
CML (t)	57.5	Drive (t)	16.5	17.0	17.0
HML (t)	57.5	Trailer Front (t)	16.5	17.0	17.0
Bridge Assessment	Tier 1	Trailer Rear (t)	16.5	17.0	17.0

**Table 30**

Truck 2, 4, 5, 7, 10, 12, 13, 14, 15 and Trailer 15  
 Truck 18 and Trailer 15

Mass Limits	Level 2	Axle Group Masses	Level 2		
			GML	CML	HML
GML (t)	55.75	Steer (t)	6.5	6.5	6.5
CML (t)	57.25	Drive (t)	16.5	17.0	17.0
HML (t)	57.25	Trailer Front (t)	16.5	17.0	17.0
Bridge Assessment	Tier 1	Trailer Rear (t)	16.5	17.0	17.0
The mass across axle groups is limited to -					
		Axle Groups	GML	CML	HML
		2 to 4	49.25	50.75	50.75
		3 to 4	32.75	33.75	33.75

**Table 31**

Truck 4 and Trailer 2  
 Truck 15 and Trailer 2, 3  
**Truck 5 and Trailer 3**  
 Truck 6 and Trailer 4  
 Truck 18 and Trailer 2, 3

Mass Limits	Level 2	Axle Group Masses	Level 2		
			GML	CML	HML
GML (t)	54.05	Steer (t)	6.5	6.5	6.5
CML (t)	55.05	Drive (t)	16.5	17.0	17.0
HML (t)	55.55	Trailer Front (t)	16.5	17.0	17.0
Bridge Assessment	Tier 1	Trailer Rear (t)	16.5	17.0	17.0
The mass across axle groups is limited to -					
		Axle Groups	GML	CML	HML
		2 to 4	47.55	48.55	49.05
		3 to 4	31.05	32.05	32.05

**Table 32**

Truck 6 and Trailer 15

Mass Limits	Level 2	Axle Group Masses	Level 2		
			GML	CML	HML
GML (t)	55.8	Steer (t)	6.5	6.5	6.5
CML (t)	57.3	Drive (t)	16.5	17.0	17.0
HML (t)	57.3	Trailer Front (t)	16.5	17.0	17.0
Bridge Assessment	Tier 1	Trailer Rear (t)	16.5	17.0	17.0
The mass across axle groups is limited to -					
		Axle Groups	GML	CML	HML
		2 to 4	49.30	50.80	50.80
		3 to 4	32.80	33.80	33.80

**Table 33**  
**Truck 7, 15, 16, 17 and Trailer 5**  
**Truck 18 and Trailer 5**

Mass Limits	Level 2	Axle Group Masses	Level 2		
			GML	CML	HML
GML (t)	54.55	Steer (t)	6.5	6.5	6.5
CML (t)	55.55	Drive (t)	16.5	17.0	17.0
HML (t)	56.05	Trailer Front (t)	16.5	17.0	17.0
Bridge Assessment	Tier 1	Trailer Rear (t)	16.5	17.0	17.0
The mass across axle groups is limited to -					
		Axle Groups	GML	CML	HML
		2 to 4	48.05	49.05	49.55
		3 to 4	31.55	32.55	32.55

**Table 34**  
**Truck 8 and Trailer 15**

Mass Limits	Level 2	Axle Group Masses	Level 2		
			GML	CML	HML
GML (t)	55.7	Steer (t)	6.5	6.5	6.5
CML (t)	57.2	Drive (t)	16.5	17.0	17.0
HML (t)	57.2	Trailer Front (t)	16.5	17.0	17.0
Bridge Assessment	Tier 1	Trailer Rear (t)	16.5	17.0	17.0
The mass across axle groups is limited to -					
		Axle Groups	GML	CML	HML
		2 to 4	49.20	50.70	50.70
		3 to 4	32.70	33.70	33.70

**Table 35**  
**Truck 9, 15, 16, 17 and Trailer 7**  
**Truck 18 and Trailer 7**

Mass Limits	Level 2	Axle Group Masses	Level 2		
			GML	CML	HML
GML (t)	54.9	Steer (t)	6.5	6.5	6.5
CML (t)	55.9	Drive (t)	16.5	17.0	17.0
HML (t)	56.4	Trailer Front (t)	16.5	17.0	17.0
Bridge Assessment	Tier 1	Trailer Rear (t)	16.5	17.0	17.0
The mass across axle groups is limited to -					
		Axle Groups	GML	CML	HML
		2 to 4	48.40	49.40	49.90
		3 to 4	31.90	32.90	32.90

**Table 36**  
**Truck 9 and Trailer 14**  
**Truck 16, 17 and Trailer 15**

Mass Limits	Level 2	Axle Group Masses	Level 2		
			GML	CML	HML
GML (t)	55.9	Steer (t)	6.5	6.5	6.5
CML (t)	57.4	Drive (t)	16.5	17.0	17.0
HML (t)	57.4	Trailer Front (t)	16.5	17.0	17.0
Bridge Assessment	Tier 1	Trailer Rear (t)	16.5	17.0	17.0
The mass across axle groups is limited to -					
		Axle Groups	GML	CML	HML
		2 to 4	49.40	50.90	50.90
		3 to 4	32.90	33.90	33.90

**Table 37**  
**Truck 9 and Trailer 15**

Mass Limits	Level 2	Axle Group Masses	Level 2		
			GML	CML	HML
GML (t)	55.6	Steer (t)	6.5	6.5	6.5
CML (t)	57.1	Drive (t)	16.5	17.0	17.0
HML (t)	57.1	Trailer Front (t)	16.5	17.0	17.0
Bridge Assessment	Tier 1	Trailer Rear (t)	16.5	17.0	17.0
The mass across axle groups is limited to -					
		Axle Groups	GML	CML	HML
		2 to 4	49.10	50.60	50.60
		3 to 4	32.60	33.60	33.60

**Table 38**  
**Truck 11, 15, 16, 17 and Trailer 10**  
**Truck 18 and Trailer 10**

Mass Limits	Level 2	Axle Group Masses	Level 2		
			GML	CML	HML
GML (t)	55.05	Steer (t)	6.5	6.5	6.5
CML (t)	56.55	Drive (t)	16.5	17.0	17.0
HML (t)	56.55	Trailer Front (t)	16.5	17.0	17.0
Bridge Assessment	Tier 1	Trailer Rear (t)	16.5	17.0	17.0
The mass across axle groups is limited to -					
		Axle Groups	GML	CML	HML
		2 to 4	48.55	50.05	50.05
		3 to 4	32.05	33.05	33.05

**Table 39**  
**Truck 9 and Trailer 17**  
**Truck 13, 15 and Trailer 12**  
**Truck 18 and Trailer 12**

Mass Limits	Level 2	Axle Group Masses	Level 2		
			GML	CML	HML
GML (t)	55.85	Steer (t)	6.5	6.5	6.5
CML (t)	57.35	Drive (t)	16.5	17.0	17.0
HML (t)	57.35	Trailer Front (t)	16.5	17.0	17.0
Bridge Assessment	Tier 1	Trailer Rear (t)	16.5	17.0	17.0
The mass across axle groups is limited to -					
		Axle Groups	GML	CML	HML
		2 to 4	49.35	50.85	50.85
		3 to 4	32.85	33.85	33.85

**Table 40**  
**Truck 16, 17 and Trailer 2, 3**

Mass Limits	Level 2	Axle Group Masses	Level 2		
			GML	CML	HML
GML (t)	54.05	Steer (t)	6.5	6.5	6.5
CML (t)	55.05	Drive (t)	16.5	17.0	17.0
HML (t)	55.55	Trailer Front (t)	16.5	17.0	17.0
Bridge Assessment	Tier 1	Trailer Rear (t)	16.5	17.0	17.0
The mass across axle groups is limited to -					
		Axle Groups	GML	CML	HML
		2 to 4	47.55	48.55	49.05
		3 to 4	31.05	32.05	32.05

**Table 41**  
**Truck 16 and Trailer 16**

Mass Limits	Level 1	Axle Group Masses	Level 1
			GML
GML (t)	50.5	Steer (t)	6.5
CML (t)	NA	Drive (t)	16.5
HML (t)	NA	Trailer Front (t)	15.0
Bridge Assessment	Tier 1	Trailer Rear (t)	15.0
The mass across axle groups is limited to -			
		Axle Groups	GML
		2 to 4	44.95
		3 to 4	28.45

## Operating conditions

The NHVR approves the vehicles listed herein for the levels shown in the “Mass Limits” table with the following operating conditions:

1. The total combination mass must not exceed the limits in the “Mass Limits” table.
2. The axle group masses must not exceed the limits in the “Axle Group Masses” table.
3. If the “Mass Limits” table specifies Tier 2 or Tier 3, a bridge assessment is required.
4. Maximum payload heights measured from the ground must not exceed: (m)

<b>VARIANT 1</b>	Heaped Payload	Water Level Payload
Truck	2.950	2.750
Trailer	2.950	2.750

<b>VARIANT 2</b>	Heaped Payload	Water Level Payload
Truck	2.900	2.700
Trailer	2.900	2.700

5. 6.5 tonne complying steer axle requirements:
  - an engine that complies with the engine emission standards of Australian Design Rule (ADR) 80/01 (Euro 4) or a later version of ADR 80; and
  - a front underrun protection device (FUPD) that complies with UN ECE Regulation 93 or ADR 84; and
  - a cabin that complies with UN ECE Regulation 29.
6. Concessional Mass Limits (CML) requirements:
  - a National Heavy Vehicle Accreditation Scheme (NHVAS) – Mass Management Accreditation must be in force for all motor vehicles listed on this vehicle approval.
7. Higher Mass Limits (HML) requirements:
  - for tandem axles groups, road friendly suspensions.
8. When operating at Level 1, there is a minimum mass requirement for the drive axle group. The mass on the drive axle group must be at least 26% of the total combination mass e.g. at 50.5t total combination mass,  $50.5 \times 0.26 = 13.13t$  is required on the drive axle group. This clause does not apply to an unladen vehicle.
9. When operating at Level 2, there is a minimum mass requirement for the drive axle group. The mass on the drive axle group must be at least 20% of the total combination mass e.g. at 56t total combination mass,  $56 \times 0.2 = 11.2t$  is required on the drive axle group. This clause does not apply to an unladen vehicle.
10. If drawbar length exceeds 5m, the outermost surface of the drawbar must be fitted with yellow reflective material that complies with Class C material requirements of United National Economic Commission for Europe Regulation No. 104 Uniform provisions concerning the approval of retro-reflective markings for vehicles of category M, N and O.
11. Due to the vehicle’s length (Combinations over 20m) exceeding the maximum permitted length for Level 1 access as prescribed by the Network Classification Guidelines, the access of this vehicle will be limited and an individual route assessment will be required. The operation of the vehicle on the road network will require a permit subject to Road Manager Consent, unless otherwise specified by the Road Manager.

## Exemptions

*Heavy Vehicle National Law Section 24*

*Heavy Vehicle (General) National Regulation Section 28*

The following table lists exemptions from prescribed vehicle standards that have been granted for the vehicles in this vehicle approval.

Exemptions	
ADR	Rule 43, Clause 6.2.2 (Drawbar length – Trailers) Rule 43, Clause 9.4 (Retractable axles)
HV(MDL)NR	Schedule 6, Section 3 (Length – General) Schedule 6, Section 6 (Length – Trailer drawbars)
HV(VS)NR	NA



ADR Australian Design Rules

HV(MDL)NR *Heavy Vehicle (Mass, Dimension and Loading) National Regulation*

HV(VS)NR *Heavy Vehicle (Vehicle Standards) National Regulation*

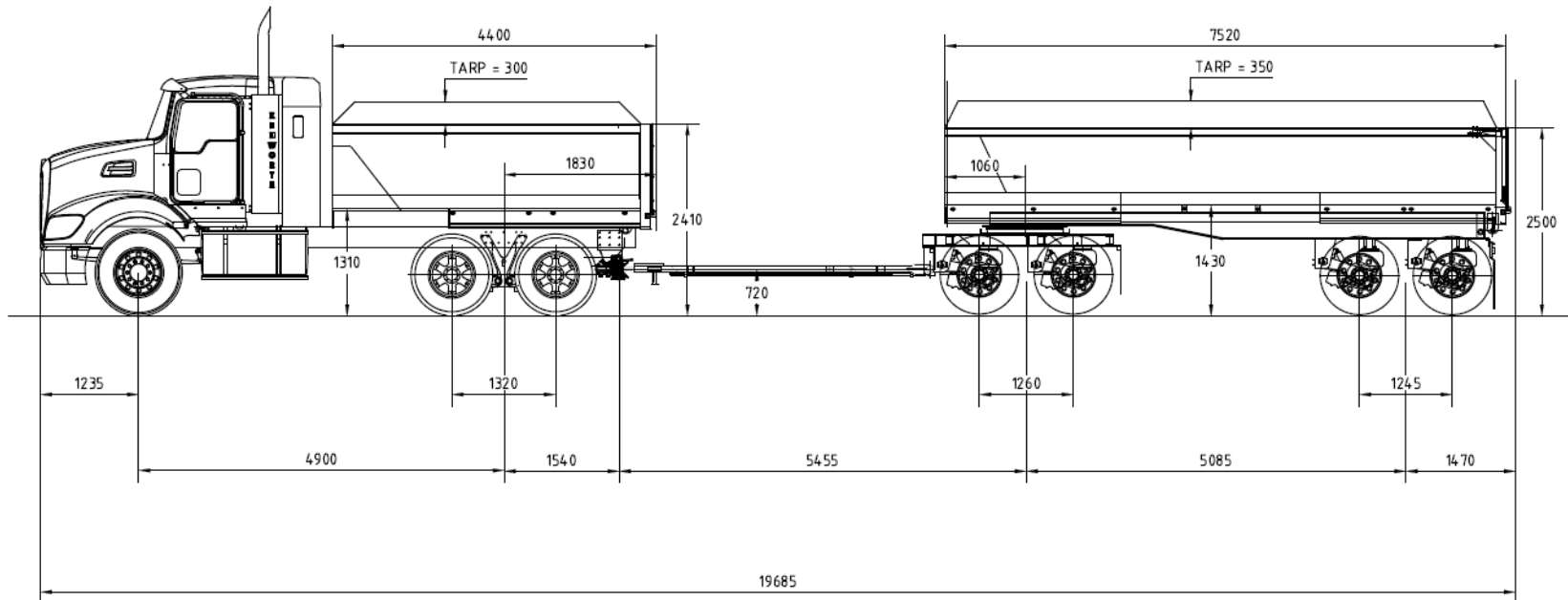

TRUCK 2  
TRAILER 8

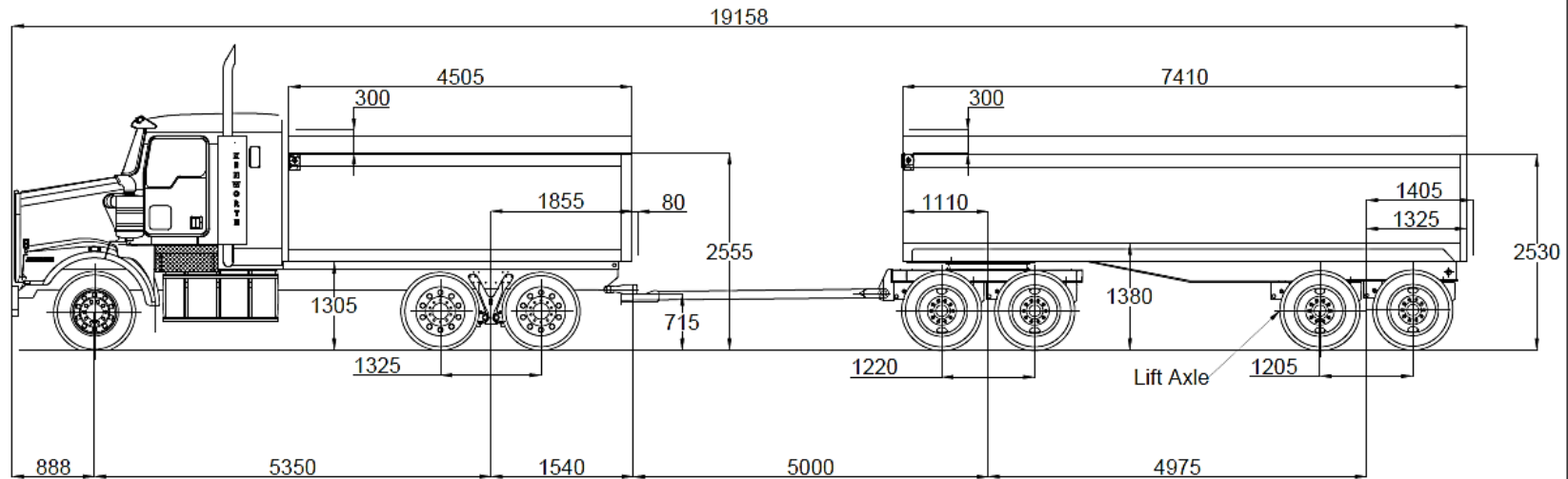

					ALL DIMENSIONS IN mm UNLESS SPECIFIED TOLERANCES UNLESS SPECIFIED ±/- 20 mm	 www.smedleys.co engineers@smedleys.co 110 HIGHETT ST, RICHMOND, VIC 3121	ER220649 – VEHICLE LAYOUT DRAWING B&L DIRTWORKS R12D22 – TRUCK AND QUAD DOG					
A	INITIAL ISSUE	DMS	DJS	11/07/22	 DO NOT SCALE	<small>THIS DRAWING AND DESIGN REMAINS THE PROPERTY OF SMEDLEY'S ENGINEERS PTY LTD AND MUST NOT BE COPIED, LOANED OR OTHERWISE USED WITHOUT THE EXPRESSED PERMISSION OR LICENCE IN WRITING. RETURN IMMEDIATELY UPON THE REQUEST. LOSS OF ALL COPIES OF THIS DRAWING IN THE POSSESSION OF THE RECIPIENT OTHER THAN THOSE REQUIRED FOR THE RECIPIENT'S RECORDS AND ANY UNAUTHORISED USE OF THIS DRAWING INCLUDING ITS REPRODUCTION IN THREE DIMENSIONAL FORM, MAY CONSTITUTE A VIOLATION OF THE COPYRIGHT ACT 1968</small>						
REV.	DESCRIPTION	DRAWN	APPR.	DATE	AS 1100:1992	DMS	DJS	11/07/22	No Scale	A4	1 of 1	DWG No B&L01_014

Truck 4  
Trailer 2



					ALL DIMENSIONS IN mm UNLESS SPECIFIED TOLERANCES UNLESS SPECIFIED ± 20mm		ER210154 PBS C B&L Dirtworks V161112 r12d22 PBS Layout						
							www.smedleys.co engineers@smedleys.co 110 Hightett St, Richmond, Vic 3121						
							THIS DRAWING AND DESIGN REMAINS THE PROPERTY OF SMEDLEY'S ENGINEERS PTY LTD AND MUST NOT BE COPIED, LOANED OR OTHERWISE USED WITHOUT THE EXPRESS PERMISSION OR LICENCE IN WRITING. RETURN IMMEDIATELY UPON ITS REQUEST TO DO SO. ALL COPIES OF THIS DRAWING IN THE POSSESSION OF THE RECIPIENT OTHER THAN THOSE REQUIRED FOR THE RECIPIENT'S RECORDS AND ANY UNAUTHORISED USE OF THIS DRAWING INCLUDING ITS REPRODUCTION IN THREE DIMENSIONAL FORM, MAY CONSTITUTE A VIOLATION OF THE COPYRIGHT ACT 1968						
REV.	Description	DRAWN	APPR.	DATE		DO NOT SCALE	DRAWN MR	CHECKED JH	DATE 24/02/21	SCALE No Scale	SIZE A4	SHEET 1 of 1	DWG NO B&L01_003



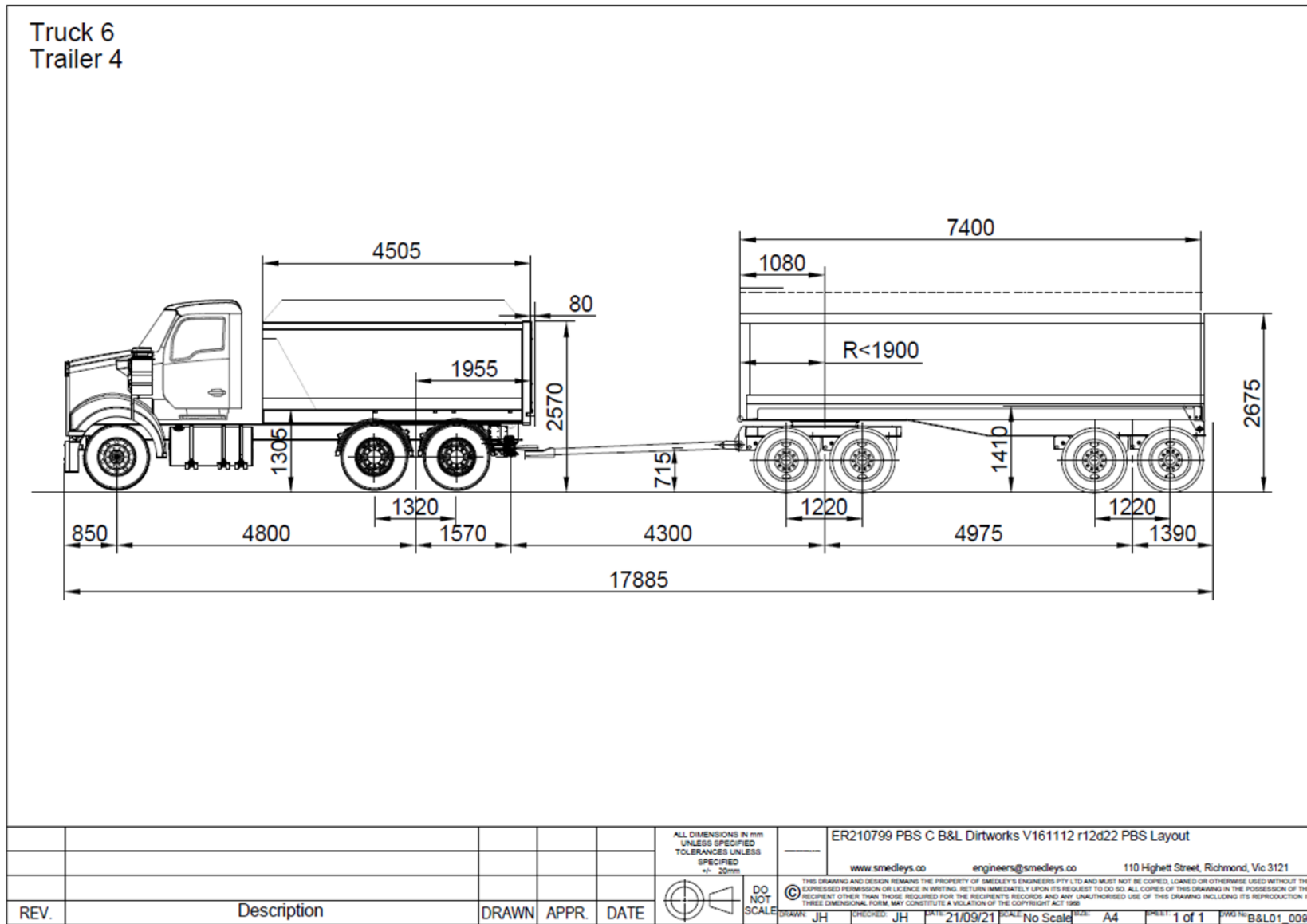

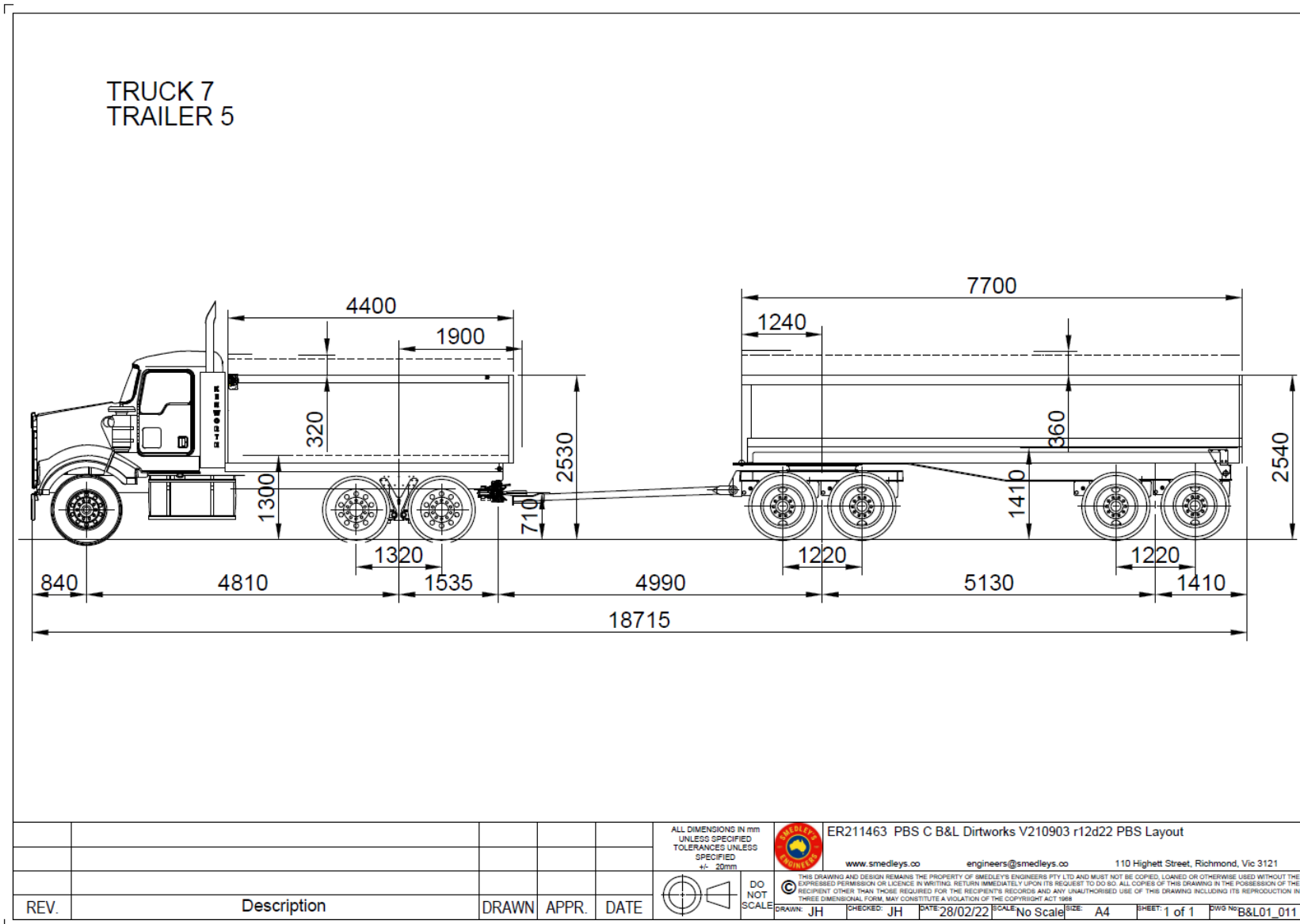

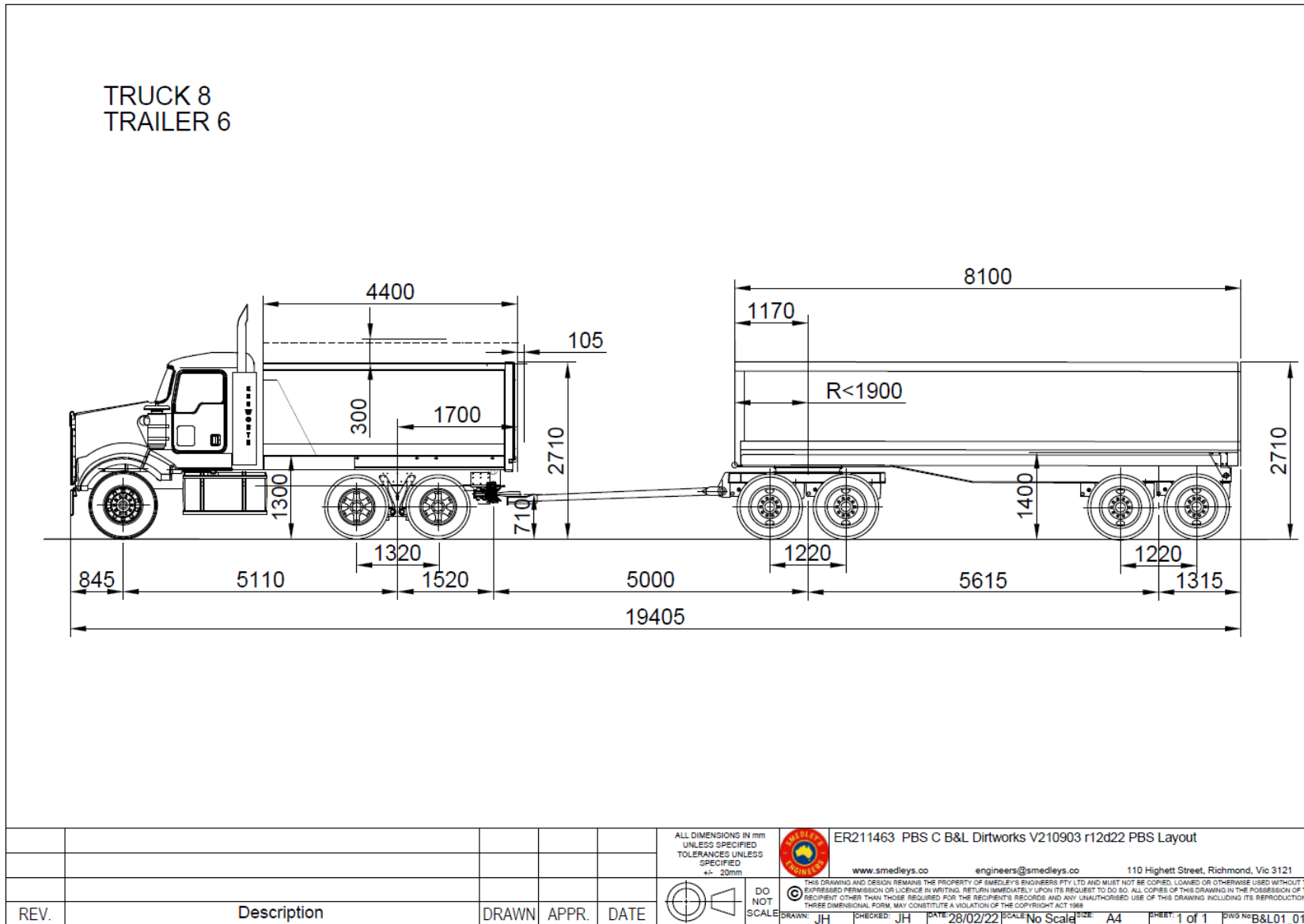

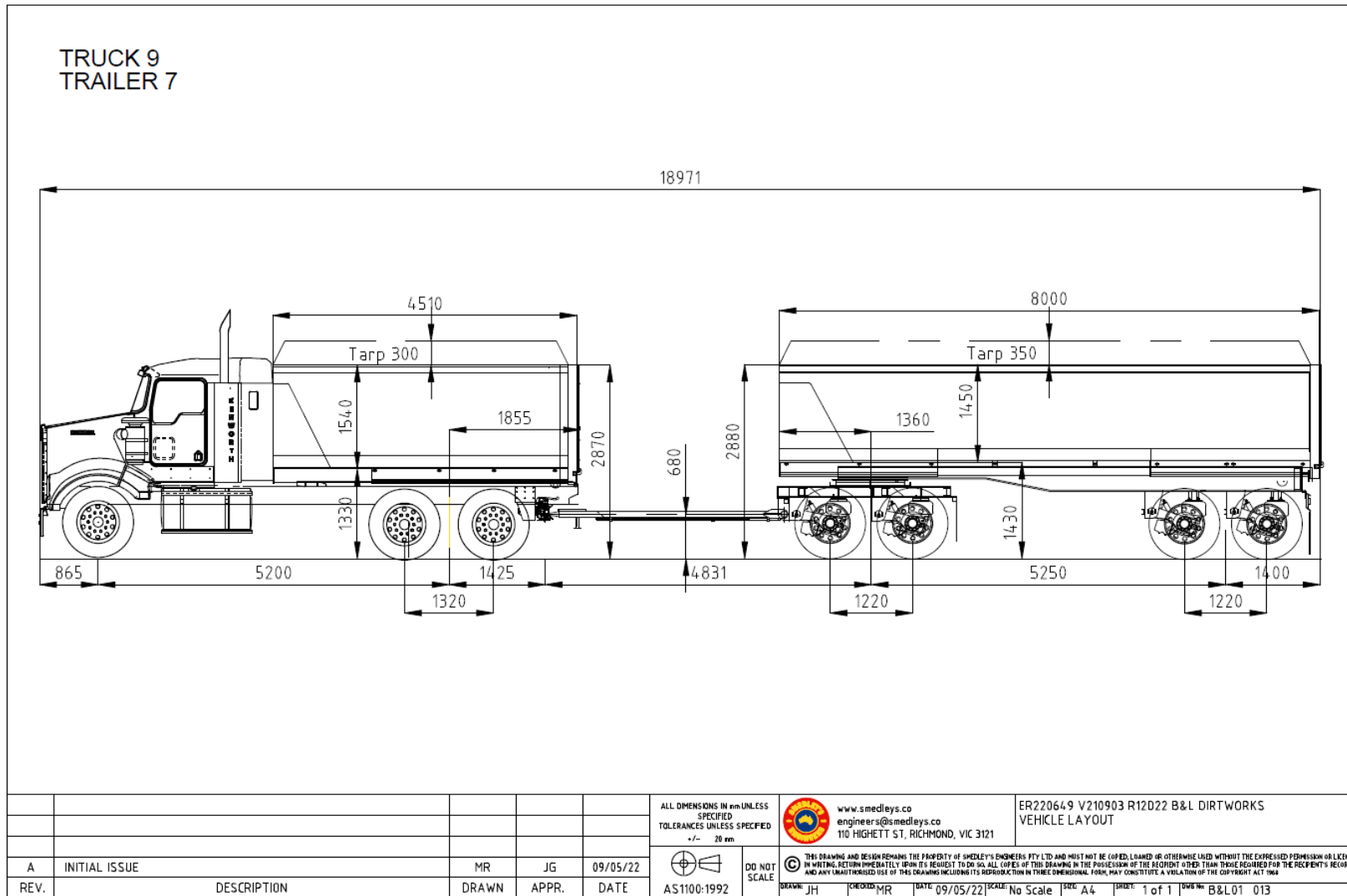

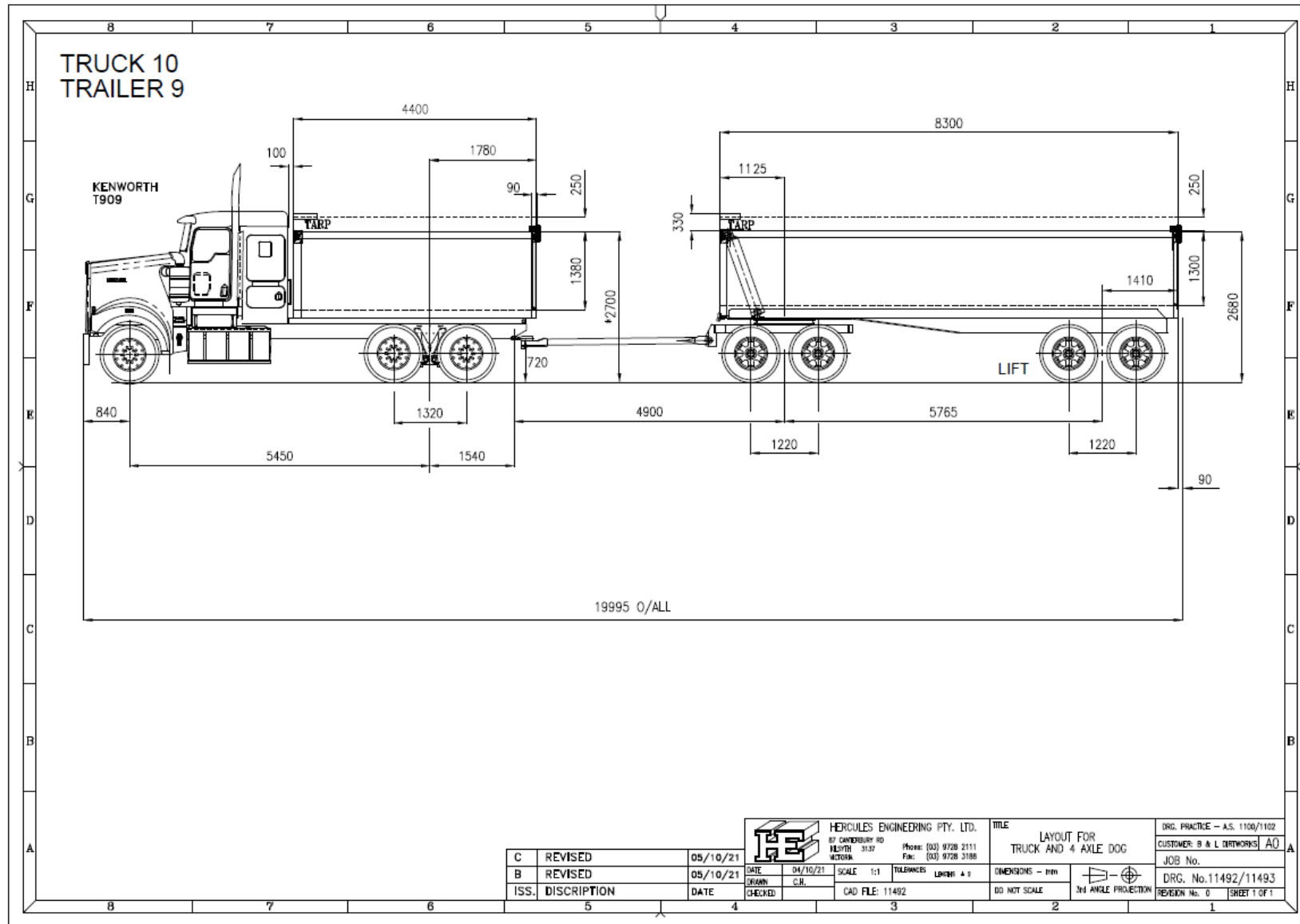

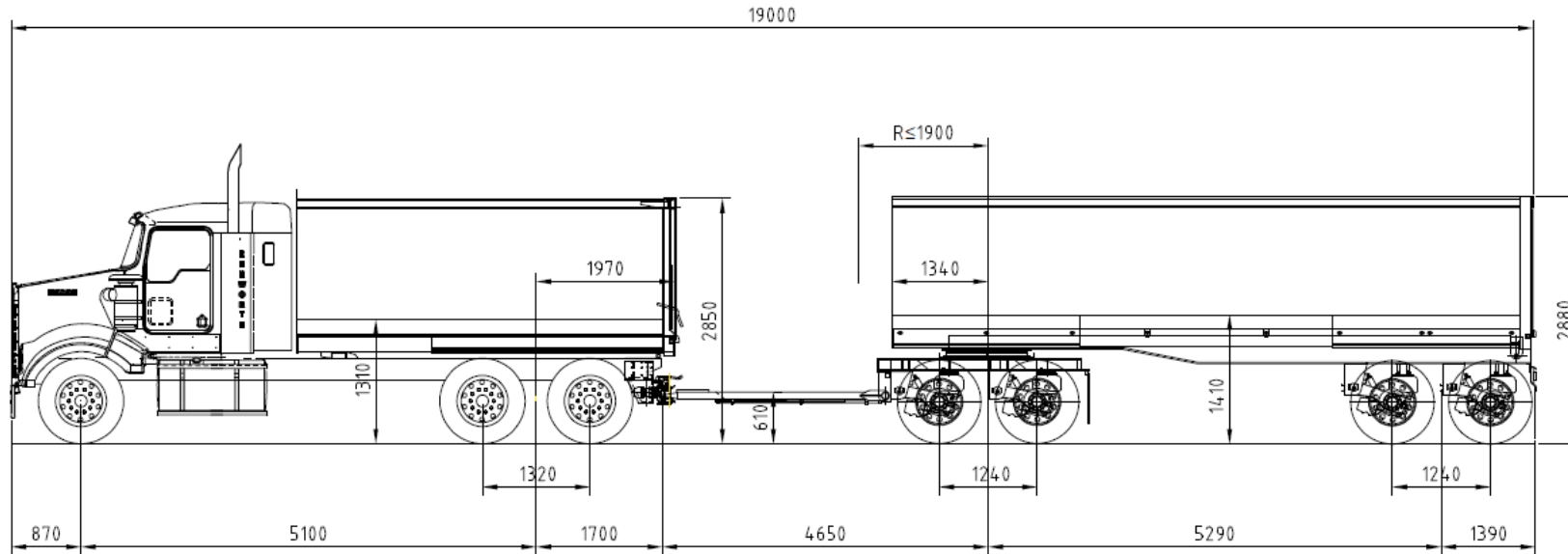

TRUCK 11  
TRAILER 10



					ALL DIMENSIONS IN mm UNLESS SPECIFIED TOLERANCES UNLESS SPECIFIED: ± 0.20 mm	 www.smedleys.co engineers@smedleys.co 110 HIGHETT ST, RICHMOND, VIC 3121	ER222389 B&L Dirtworks V210903 r12d22
REV.	DESCRIPTION	DRAWN	APPR.	DATE	AS1100:1992	THIS DRAWING AND DESIGN REMAINS THE PROPERTY OF SMEDLEY'S ENGINEERS PTY LTD AND MUST NOT BE COPIED, LOANED OR OTHERWISE USED WITHOUT THE EXPRESSED PERMISSION OR LICENSE IN WRITING. RETURN IMMEDIATELY UPON ITS REQUEST TO DO SO. ALL COPIES OF THIS DRAWING IN THE POSSESSION OF THE RECIPIENT OTHER THAN THOSE REQUIRED FOR THE RECIPIENT'S RECORDS AND ANY UNAUTHORIZED USE OF THIS DRAWING INCLUDING ITS REPRODUCTION IN THREE DIMENSIONAL FORM, MAY CONSTITUTE A VIOLATION OF THE COPYRIGHT ACT 1968.	DRAWN: BS   CHECKED: JH   DATE: 11/01/23   SCALE: No Scale   SIZE: A4   SHEET: 1 of 1   DWG No: B&L01_015

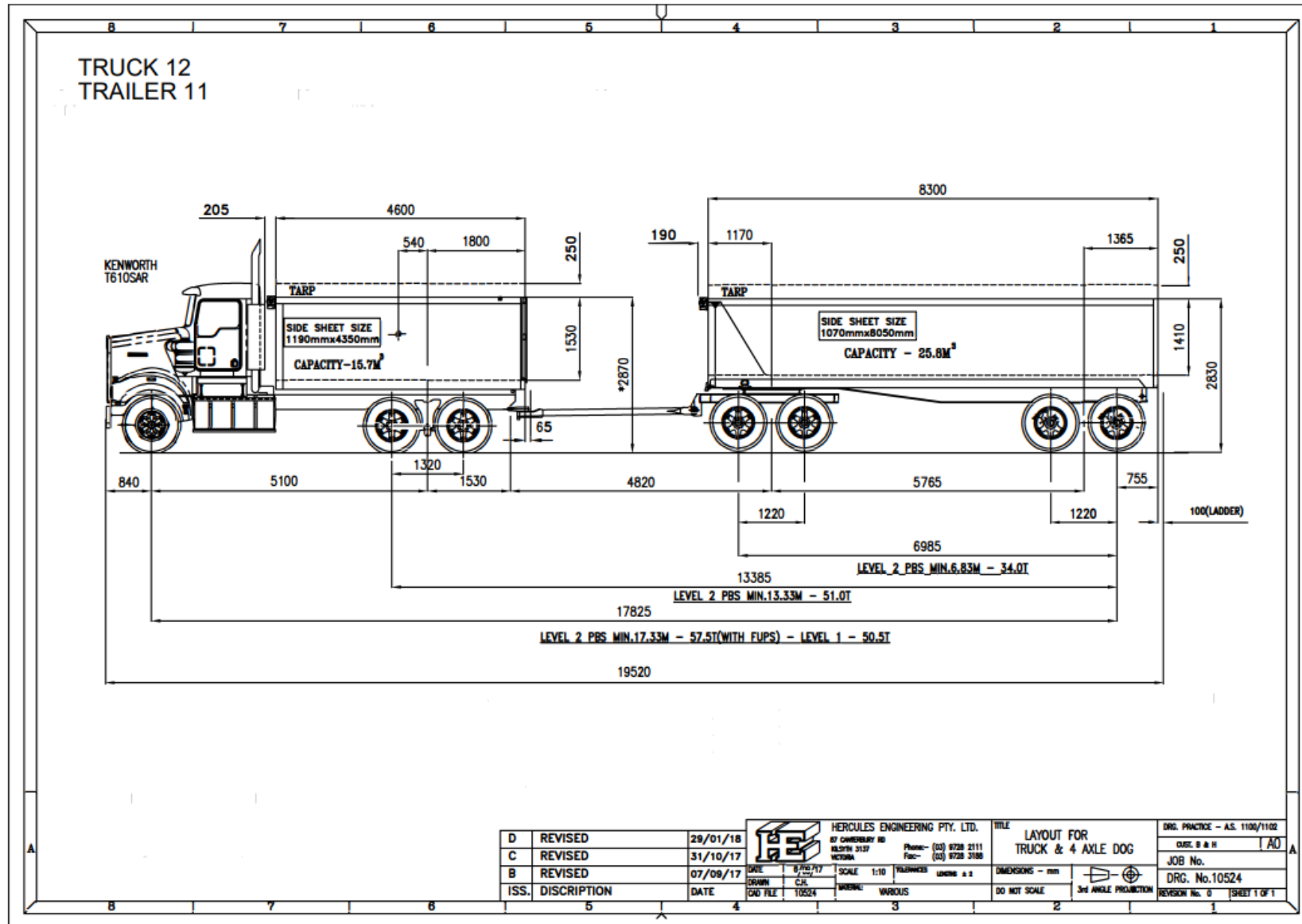

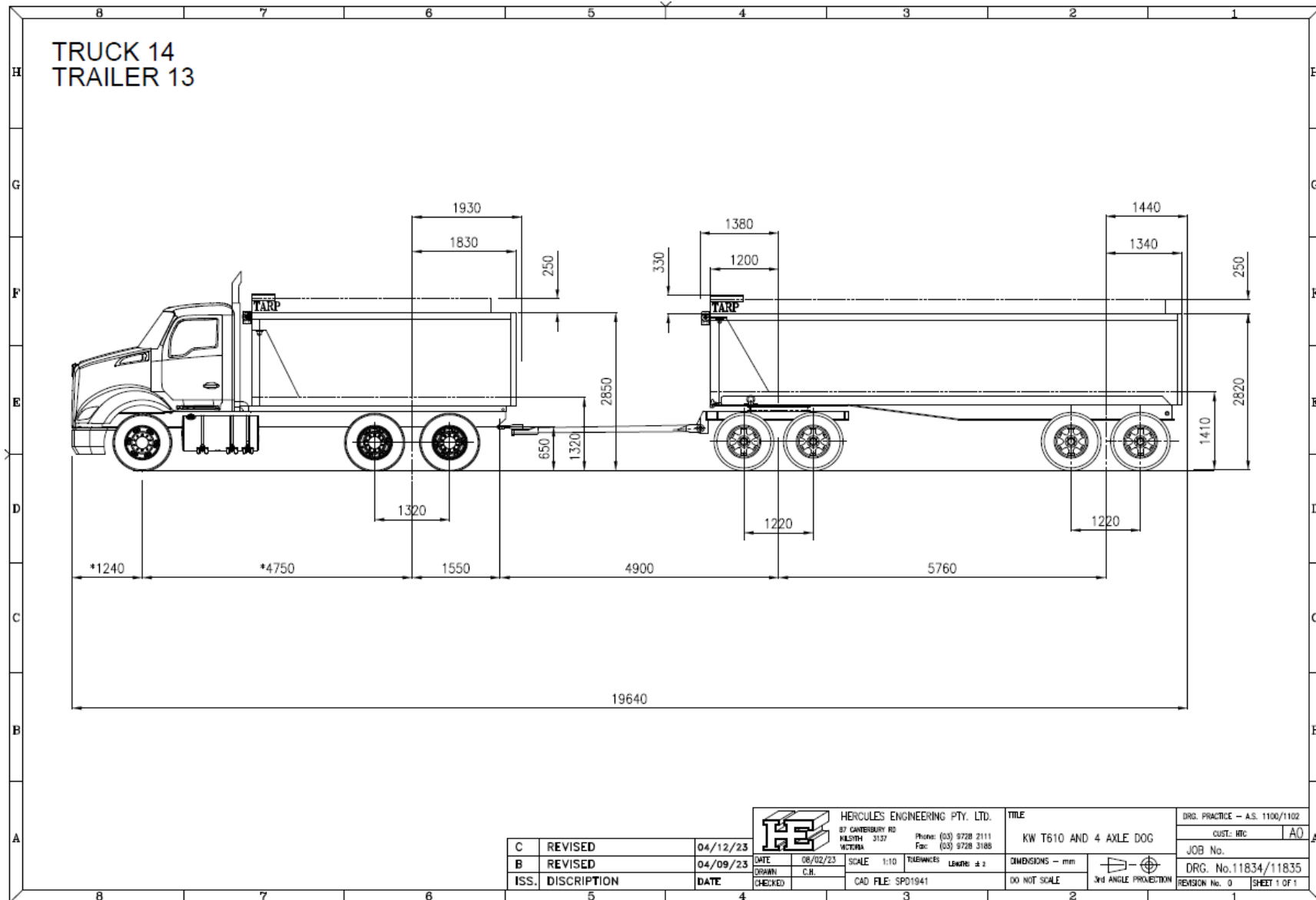

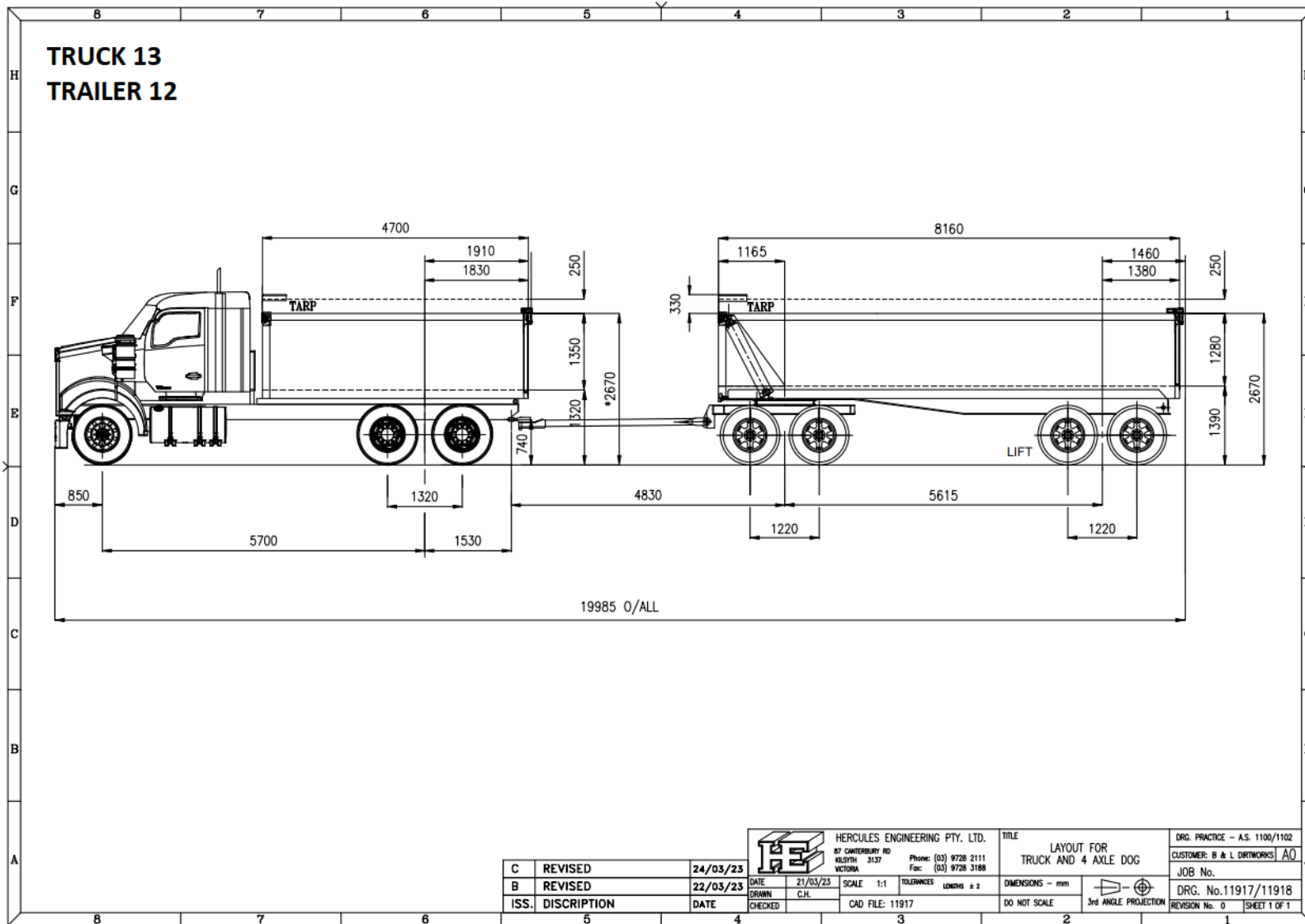

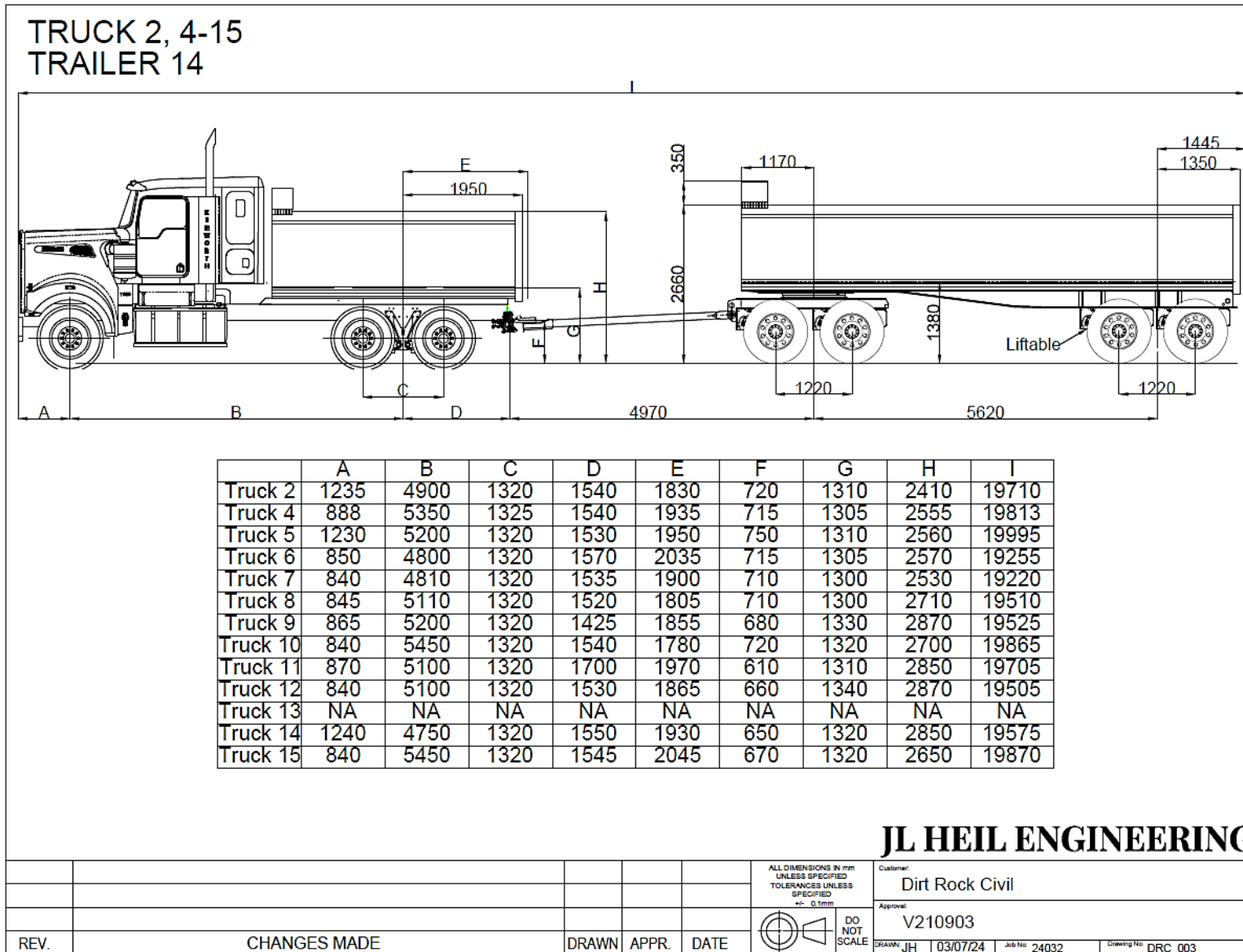

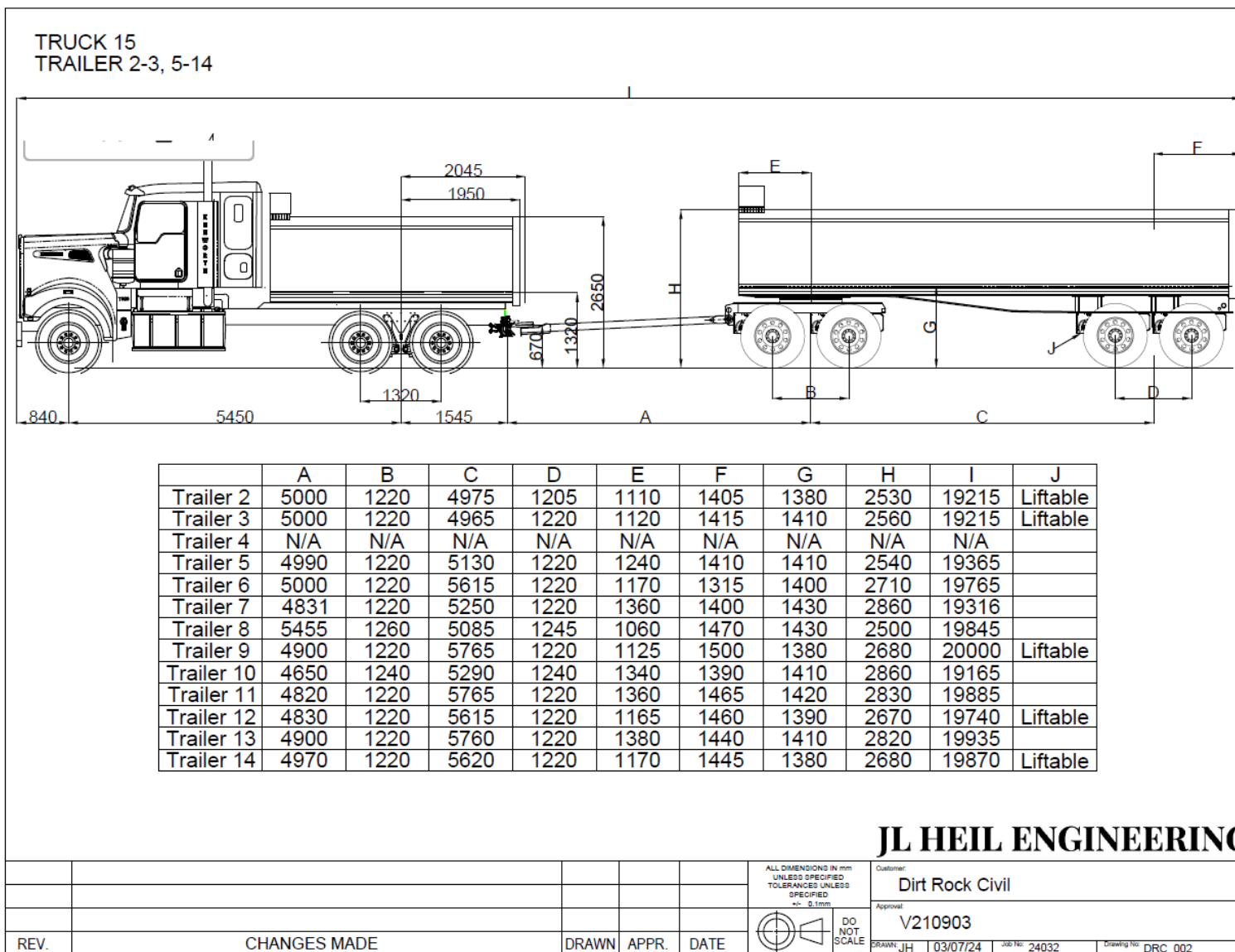

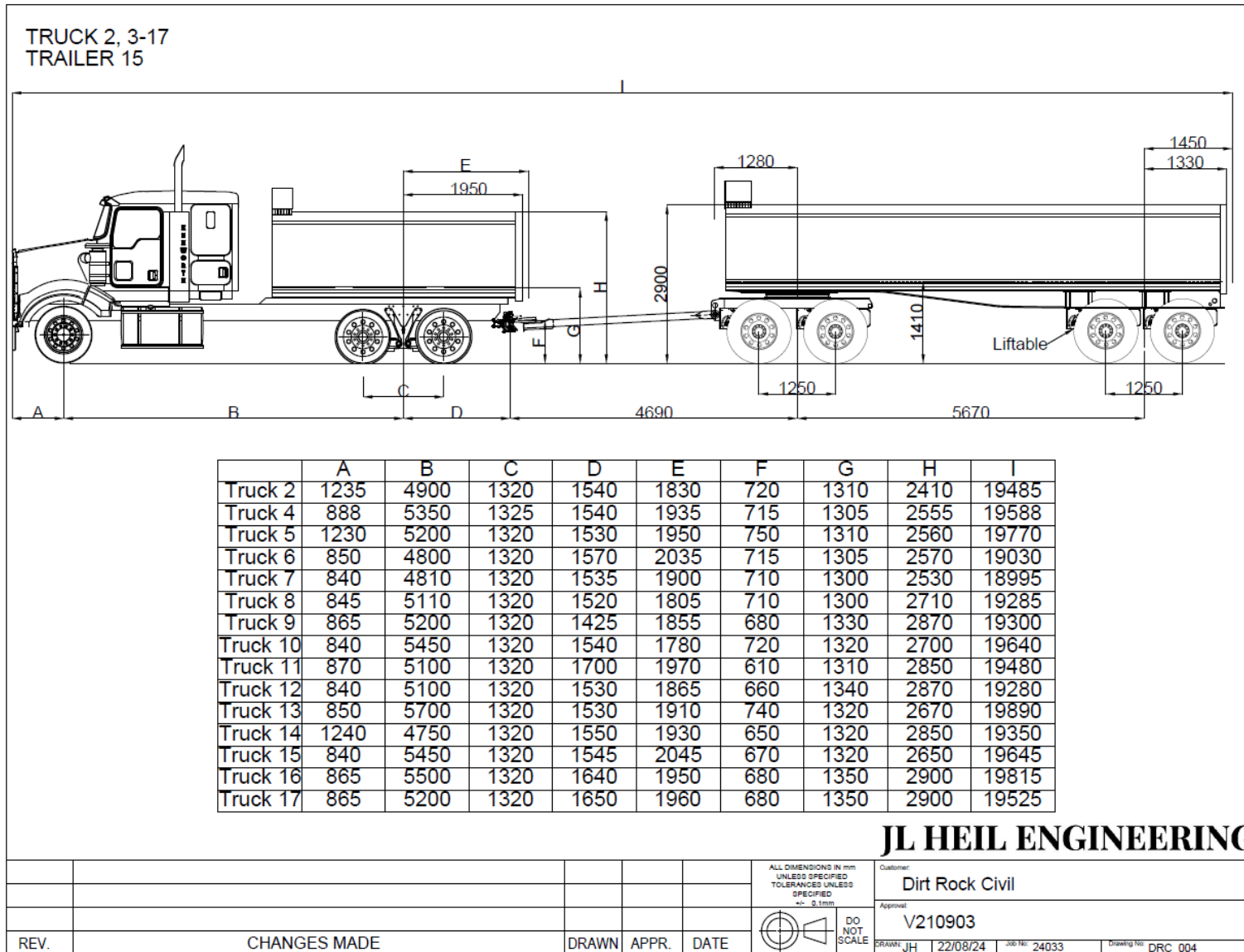

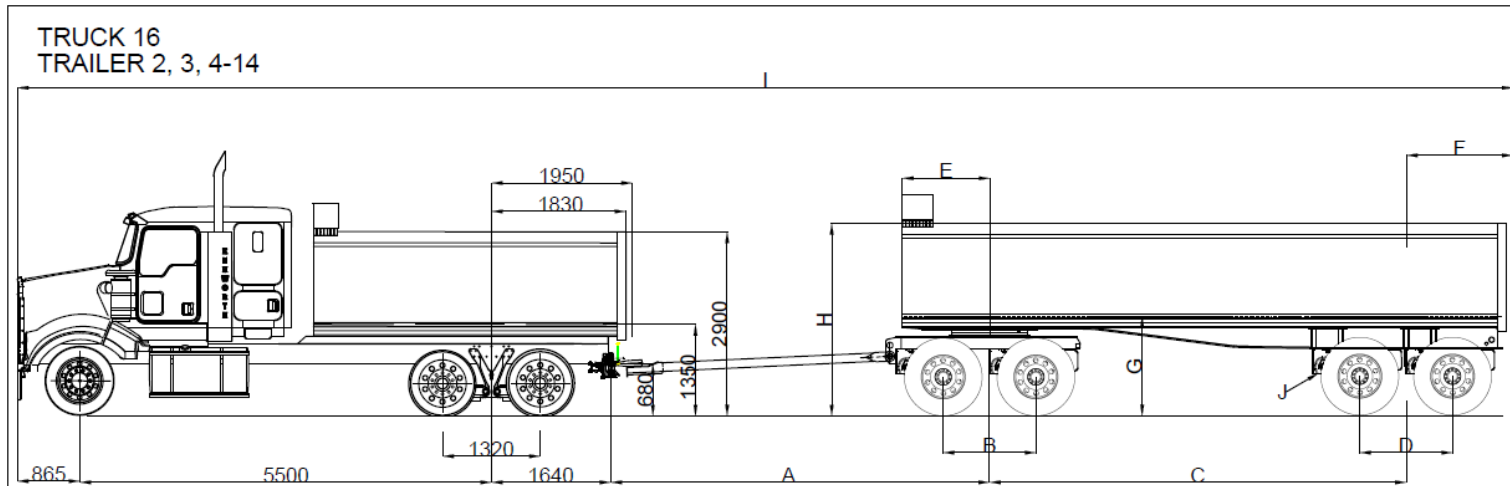

	A	B	C	D	E	F	G	H	I	J
Trailer 2	5000	1220	4965	1205	1110	1405	1380	2530	19385	Liftable
Trailer 3	5000	1220	4965	1220	1120	1415	1410	2560	19385	Liftable
Trailer 4	N/A	N/A	N/A	N/A	N/A	N/A	N/A	N/A	N/A	
Trailer 5	4990	1220	5130	1220	1240	1410	1410	2540	19535	
Trailer 6	5000	1220	5615	1220	1170	1315	1400	2710	19935	
Trailer 7	4831	1220	5250	1220	1360	1400	1430	2860	19486	
Trailer 8	5455	1260	5085	1245	1060	1470	1430	2500	20015	
Trailer 9	4900	1220	5765	1220	1125	1500	1380	2680	20170	Liftable
Trailer 10	4650	1240	5290	1240	1340	1390	1410	2860	19335	
Trailer 11	4820	1220	5765	1220	1360	1465	1420	2830	20055	
Trailer 12	4830	1220	5615	1220	1165	1460	1390	2670	19910	Liftable
Trailer 13	4900	1220	5760	1220	1380	1440	1410	2820	20105	
Trailer 14	4970	1220	5620	1220	1170	1445	1380	2680	20040	Liftable

**JL HEIL ENGINEERING**

						ALL DIMENSIONS IN mm UNLESS SPECIFIED TOLERANCES UNLESS SPECIFIED ± 0.1mm	Customer: Dirt Rock Civil
						DO NOT SCALE	Approval: V210903
REV.	CHANGES MADE	DRAWN	APPR.	DATE			DRAWN: JH   22/08/24   Job No: 24033   Drawing No: DRC_005

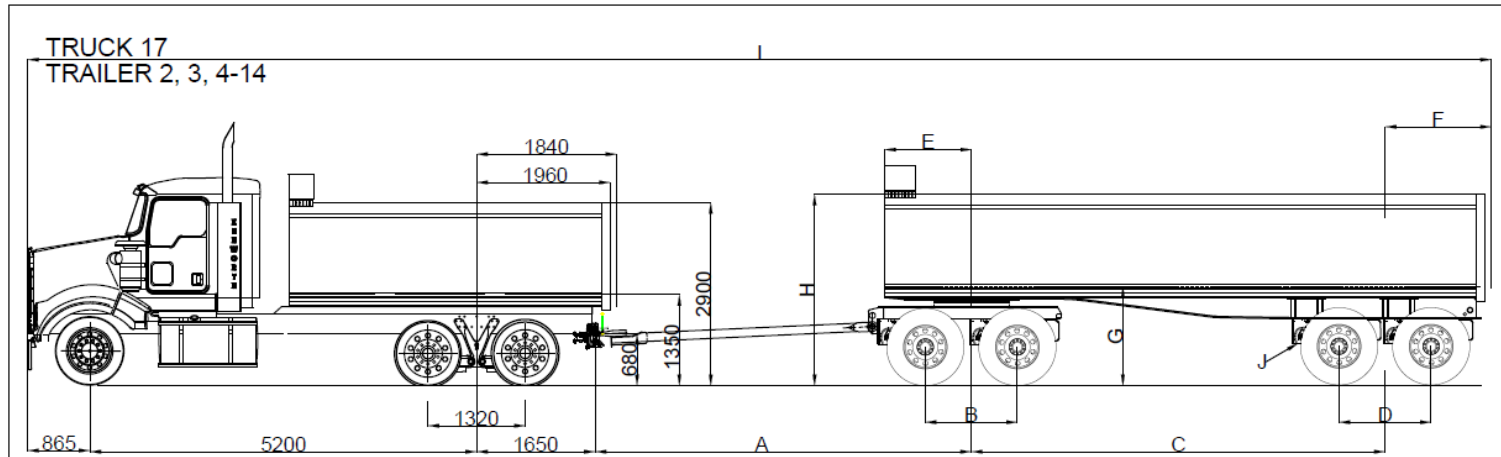

	A	B	C	D	E	F	G	H	I	J
Trailer 2	5000	1220	4975	1205	1110	1405	1380	2530	19095	Liftable
Trailer 3	5000	1220	4965	1220	1120	1415	1410	2560	19095	Liftable
Trailer 4	N/A	N/A	N/A	N/A	N/A	N/A	N/A	N/A	N/A	
Trailer 5	4990	1220	5130	1220	1240	1410	1410	2540	19245	
Trailer 6	5000	1220	5615	1220	1170	1315	1400	2710	19645	
Trailer 7	4831	1220	5250	1220	1360	1400	1430	2860	19196	
Trailer 8	5455	1260	5085	1245	1060	1470	1430	2500	19725	
Trailer 9	4900	1220	5765	1220	1125	1500	1380	2680	19880	Liftable
Trailer 10	4650	1240	5290	1240	1340	1390	1410	2860	19045	
Trailer 11	4820	1220	5765	1220	1360	1465	1420	2830	19765	
Trailer 12	4830	1220	5615	1220	1165	1460	1390	2670	19620	Liftable
Trailer 13	4900	1220	5760	1220	1380	1440	1410	2820	19815	
Trailer 14	4970	1220	5620	1220	1170	1445	1380	2680	19750	Liftable

**JL HEIL ENGINEERING**

						ALL DIMENSIONS IN mm UNLESS SPECIFIED TOLERANCES UNLESS SPECIFIED ± 0.1mm	Customer: Dirt Rock Civil
						DO NOT SCALE	Approval: V210903
REV.	CHANGES MADE	DRAWN	APPR.	DATE			DRAWN: JH 22/08/24 Job No: 24033 Drawing No: DRC_006

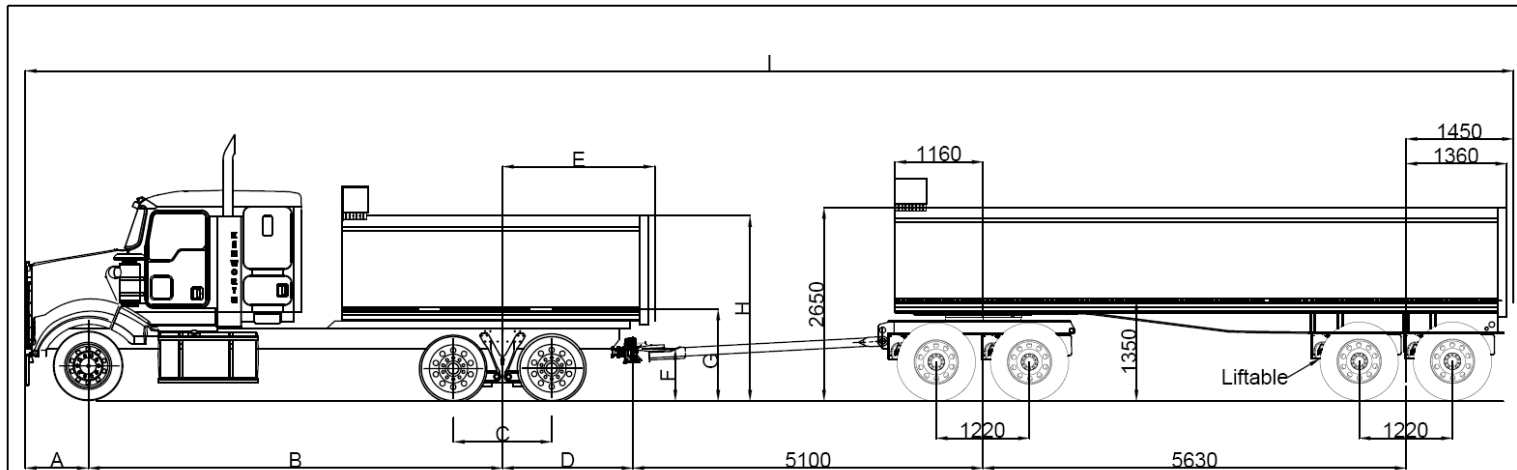

TRUCK 2, 4, 5, 6, 7, 8,  
9, 10, 11, 12, 13, 14,  
15, 16, 17, 18  
TRAILER 16

	A	B	C	D	E	F	G	H	I
Truck 2	1235	4900	1320	1540	1830	720	1310	2410	19855
Truck 4	888	5350	1325	1540	1935	715	1305	2555	19958
Truck 5	1230	5200	1320	1530	1950	750	1310	2560	20140
Truck 6	850	4800	1320	1570	2035	715	1305	2570	19400
Truck 7	840	4810	1320	1535	1900	710	1300	2530	19365
Truck 8	845	5110	1320	1520	1805	710	1300	2710	19655
Truck 9	865	5200	1320	1425	1855	680	1330	2870	19670
Truck 10	840	5450	1320	1540		720	1320	2700	20010
Truck 11	870	5100	1320	1700	1970	610	1310	2850	19850
Truck 12	840	5100	1320	1530	1865	660	1340	2870	19650
Truck 13	850	5700	1320	1530	1910	740	1320	2670	20260
Truck 14	1240	4750	1320	1550	1930	650	1320	2850	19720
Truck 15	840	5450	1320	1545	2045	670	1320	2650	20015
Truck 16	865	5500	1320	1640	1950	680	1350	2900	20185
Truck 17	865	5200	1320	1650	1960	680	1350	2900	19895
Truck 18	850	5400	1320	1540	1870	725	1320	2660	19970

**JL HEIL ENGINEERING**

						ALL DIMENSIONS IN mm UNLESS SPECIFIED TOLERANCES UNLESS SPECIFIED ±. 0.1mm	Customer: Dirt Rock Civil
						DO NOT SCALE	Approval: V210903
REV.	CHANGES MADE	DRAWN	APPR.	DATE			DRAWN: JH

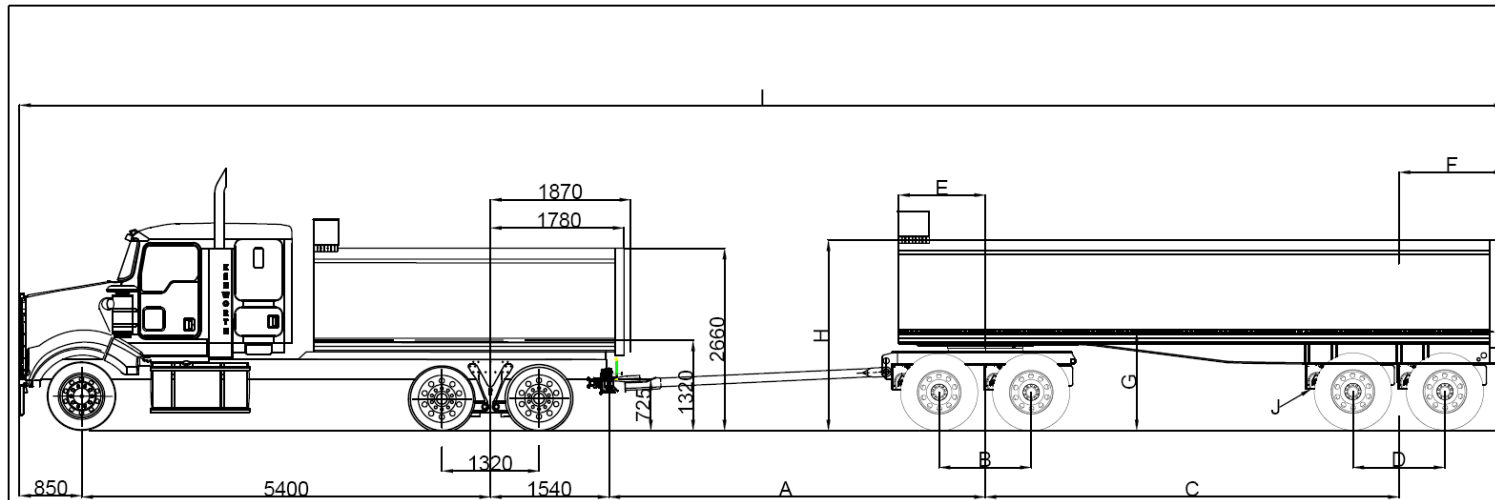

TRUCK 18  
TRAILER 2, 3,  
4, 5, 6, 7, 8, 9,  
10, 11, 12, 13,  
14, 15

	A	B	C	D	E	F	G	H	I	J
Trailer 2	5000	1220	4975	1205	1110	1405	1380	2530	19170	Liftable
Trailer 3	5000	1220	4965	1220	1120	1415	1410	2560	19170	Liftable
Trailer 4	N/A	N/A	N/A	N/A	N/A	N/A	N/A	N/A	N/A	
Trailer 5	4990	1220	5130	1220	1240	1410	1410	2540	19320	
Trailer 6	5000	1220	5615	1220	1170	1315	1400	2710	19720	
Trailer 7	4831	1220	5250	1220	1360	1400	1430	2860	19271	
Trailer 8	5455	1260	5085	1245	1060	1470	1430	2500	19800	
Trailer 9	4900	1220	5765	1220	1125	1500	1380	2680	19955	Liftable
Trailer 10	4650	1240	5290	1240	1340	1390	1410	2860	19120	
Trailer 11	4820	1220	5765	1220	1360	1465	1420	2830	19840	
Trailer 12	4830	1220	5615	1220	1165	1460	1390	2670	19695	Liftable
Trailer 13	4900	1220	5760	1220	1380	1440	1410	2820	19890	
Trailer 14	4970	1220	5620	1220	1170	1445	1380	2680	19825	Liftable
Trailer 15	4690	1250	5670	1250	1280	1450	1410	2900	19600	Liftable

**JL HEIL ENGINEERING**

						ALL DIMENSIONS IN mm UNLESS SPECIFIED TOLERANCES UNLESS SPECIFIED ±0.1mm	Customer: Dirt Rock Civil
						DO NOT SCALE	Approval: V210903
REV.	CHANGES MADE	DRAWN	APPR.	DATE			DRAWN: JH   21/01/25   Job No: 25033   Drawing No: DRC_007

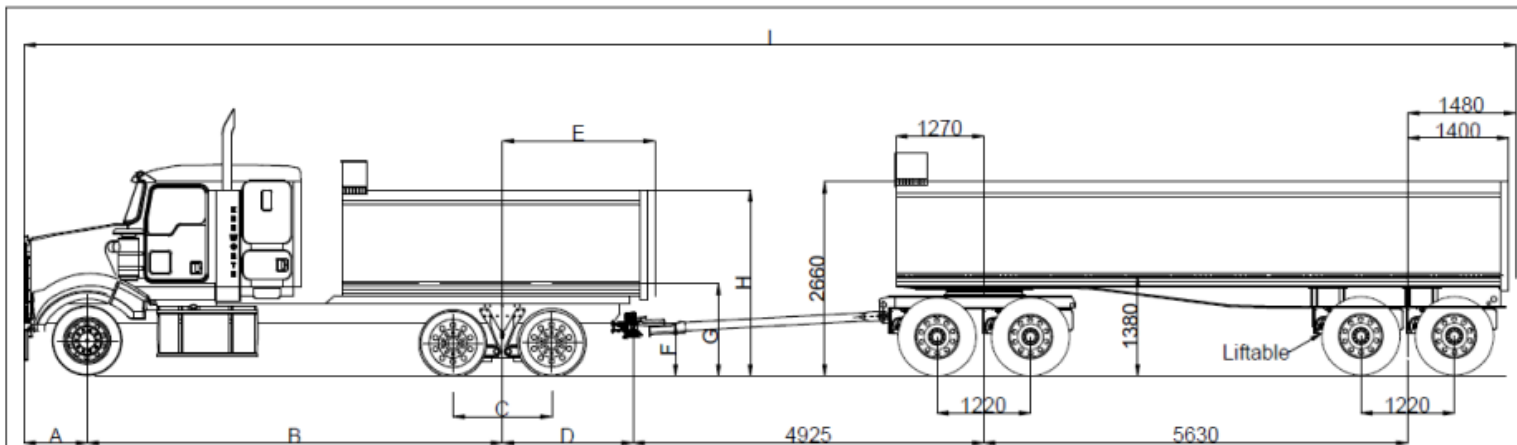

TRUCK 2, 4, 5, 6, 7, 8,  
9, 10, 11, 12, 13, 14,  
15, 16, 17, 18  
TRAILER 17

	A	B	C	D	E	F	G	H	I
Truck 2	1235	4900	1320	1540	1830	720	1310	2410	19710
Truck 4	888	5350	1325	1540	1935	715	1305	2555	19813
Truck 5	1230	5200	1320	1530	1950	750	1310	2560	19995
Truck 6	850	4800	1320	1570	2035	715	1305	2570	19255
Truck 7	840	4810	1320	1535	1900	710	1300	2530	19220
Truck 8	845	5110	1320	1520	1805	710	1300	2710	19510
Truck 9	865	5200	1320	1425	1855	680	1330	2870	19525
Truck 10	840	5450	1320	1540	1780	720	1320	2700	19865
Truck 11	870	5100	1320	1700	1970	610	1310	2850	19705
Truck 12	840	5100	1320	1530	1865	660	1340	2870	19505
Truck 13	850	5700	1320	1530	1910	740	1320	2670	20115
Truck 14	1240	4750	1320	1550	1930	650	1320	2850	19575
Truck 15	840	5450	1320	1545	2045	670	1320	2650	19870
Truck 16	865	5500	1320	1640	1950	680	1350	2900	20040
Truck 17	865	5200	1320	1650	1960	680	1350	2900	19750
Truck 18	850	5400	1320	1540	1870	725	1320	2660	19825

**JL HEIL ENGINEERING**

						ALL DIMENSIONS IN mm UNLESS SPECIFIED TOLERANCES UNLESS SPECIFIED ±0.5 mm	Customer: Dirt Rock Civil
						DO NOT SCALE	Approval: V210903
REV.	CHANGES MADE	DRAWN	APPR.	DATE			03/02/26 Job No: 25593 Drawing No: DRC_009

## Approved tyre options

### Steer –

#### *6.5t axle mass limit*

- **11R22.5** (Load Index **149** or higher, single configuration)
- **275/70R22.5** (Load Index **150** or higher, single configuration)
- **295/80R22.5** (Load Index **150** or higher, single configuration)
- **315/80R22.5** (Load Index **156** or higher, single configuration)
- **385/65R22.5** (Load Index **158** or higher, single configuration)
- **305/70R22.5** (Load Index **150** or higher, single configuration)

#### *6.0t axle mass limit*

- **11R22.5** (Load Index **146** or higher, single configuration)
- **275/70R22.5** (Load Index **146** or higher, single configuration)

### Drive –

- **11R22.5** (Load Index **142** or higher, dual configuration)
- **255/70R22.5** (Load Index **137** or higher, dual configuration)
- **265/70R19.5** (Load Index **138** or higher, dual configuration)
- **275/70R22.5** (Load Index **141** or higher, dual configuration)
- **295/60R22.5** (Load Index **147** or higher, dual configuration)
- **295/80R22.5** (Load Index **148** or higher, dual configuration)
- **305/70R22.5** (Load Index **148** or higher, dual configuration)
- **315/80R22.5** (Load Index **154** or higher, dual configuration)

### Trailer –

- **11R22.5** (Load Index **142** or higher, dual configuration)
- **255/70R22.5** (Load Index **137** or higher, dual configuration)
- **265/70R19.5** (Load Index **138** or higher, dual configuration)
- **275/70R22.5** (Load Index **141** or higher, dual configuration)
- **295/80R22.5** (Load Index **148** or higher, dual configuration)
- **305/70R22.5** (Load Index **148** or higher, dual configuration)
- **315/80R22.5** (Load Index **154** or higher, dual configuration)

Tyre load index and inflation pressure must be appropriate for the axle mass (inflation pressures must be within legal inflation limits).

Retread tyres are only permitted on the drive, dolly, and trailer axles.

Tyres listed herein are specific for PBS application number V210903.

A different list of tyres will apply for other combination types and different PBS application numbers.

Axle spacings for as-built combinations - Truck and Dog (1-2-2-2)

Truck	Trailer	1-2	2-3	3-4	4-5	5-6	6-7	OAL
2	8	4240	1320	5705	1260	3833	1245	19685
2	14	4240	1320	5240	1220	4415	1205	19710
2	15	4240	1320	4975	1220	4495	1205	19485
4	2	4688	1325	5268	1220	3763	1205	19158
4	14	4688	1325	5238	1220	4415	1205	19813
4	15	4688	1325	4973	1220	4495	1205	19588
5	3	4540	1320	5260	1220	3745	1220	19340
5	14	4540	1320	5230	1220	4415	1205	19995
5	15	4540	1320	4965	1220	4495	1205	19770
6	4	4140	1320	4600	1220	3755	1220	17885
6	14	4140	1320	5270	1220	4415	1205	19255
6	15	4140	1320	5005	1220	4495	1205	19030
7	5	4150	1320	5255	1220	3910	1220	18715
7	14	4150	1320	5235	1220	4415	1205	19220
7	15	4150	1320	4970	1220	4495	1205	18995
8	6	4450	1320	5250	1220	4395	1220	19405
8	14	4450	1320	5220	1220	4415	1205	19510
5	15	4450	1320	4955	1220	4495	1205	19285
9	7	4540	1320	4986	1220	4030	1220	18971
9	14	4540	1320	5125	1220	4415	1205	19525
9	15	4540	1320	4860	1220	4495	1205	19300
10	9	4790	1320	5170	1220	4545	1220	19995
10	14	4790	1320	5240	1220	4415	1205	19865
10	15	4790	1320	4975	1220	4495	1205	19640
11	10	4440	1320	5070	1240	4050	1240	19000
11	14	4440	1320	5400	1220	4415	1205	19705
11	15	4440	1320	5135	1220	4495	1205	19480
12	11	4440	1320	5080	1220	4560	1205	19520
12	14	4440	1320	5230	1220	4415	1205	19505
12	15	4440	1320	4965	1220	4495	1205	19280
13	12	5040	1320	5090	1220	4410	1205	19985
13	15	5040	1320	4965	1220	4495	1205	19890
14	13	4090	1320	5180	1220	4555	1205	19640
14	14	4090	1320	5250	1220	4415	1205	19575
14	15	4090	1320	4985	1220	4495	1205	19350
15	2	4790	1320	5275	1220	3763	1205	19215
15	3	4790	1320	5275	1220	3745	1220	19215
15	5	4790	1320	5265	1220	3910	1220	19365
15	6	4790	1320	5275	1220	4395	1220	19765
15	7	4790	1320	5106	1220	4030	1220	19316
15	8	4790	1320	5710	1260	3833	1245	19845
15	9	4790	1320	5175	1220	4545	1220	20000
15	10	4790	1320	4915	1240	4050	1240	19165
15	11	4790	1320	5095	1220	4560	1205	19885
15	12	4790	1320	5105	1220	4410	1205	19740
15	13	4790	1320	5175	1220	4555	1205	19935
15	14	4790	1320	5245	1220	4415	1205	19870
15	15	4790	1320	4980	1220	4495	1205	19645
16	2	4840	1320	5370	1220	3763	1205	19385
16	3	4840	1320	5370	1220	3745	1220	19385
16	5	4840	1320	5360	1220	3910	1220	19535

16	6	4840	1320	5370	1220	4395	1220	19935
16	7	4840	1320	5201	1220	4030	1220	19486
16	8	4840	1320	5805	1260	3833	1245	20015
16	9	4840	1320	5270	1220	4545	1220	20170
16	10	4840	1320	5010	1240	4050	1240	19335
16	11	4840	1320	5190	1220	4560	1205	20055
16	12	4840	1320	5200	1220	4410	1205	19910
16	13	4840	1320	5270	1220	4555	1205	20105
16	14	4840	1320	5340	1220	4415	1205	20040
16	15	4840	1320	5075	1220	4495	1205	19815
16	2	4540	1320	5380	1220	3763	1205	19095
17	3	4540	1320	5380	1220	3745	1220	19095
17	5	4540	1320	5370	1220	3910	1220	19245
17	6	4540	1320	5380	1220	4395	1220	19645
17	7	4540	1320	5211	1220	4030	1220	19196
17	8	4540	1320	5815	1260	3833	1245	19725
17	9	4540	1320	5280	1220	4545	1220	19880
17	10	4540	1320	5020	1240	4050	1240	19045
17	11	4540	1320	5200	1220	4560	1205	19765
17	12	4540	1320	5210	1220	4410	1205	19620
17	13	4540	1320	5280	1220	4555	1205	19815
17	14	4540	1320	5350	1220	4415	1205	19750
17	15	4540	1320	5085	1220	4495	1205	19525
2	16	4240	1320	5370	1220	4425	1205	19855
4	16	4688	1325	5368	1220	4425	1205	19958
5	16	4540	1320	5360	1220	4425	1205	20140
6	16	4140	1320	5400	1220	4425	1205	19400
7	16	4150	1320	5365	1220	4425	1205	19365
8	16	4450	1320	5350	1220	4425	1205	19655
9	16	4540	1320	5255	1220	4425	1205	19670
10	16	4790	1320	5370	1220	4425	1205	20010
11	16	4440	1320	5530	1220	4425	1205	19850
12	16	4440	1320	5360	1220	4425	1205	19650
13	16	5040	1320	5360	1220	4425	1205	20260
14	16	4090	1320	5380	1220	4425	1205	19720
15	16	4790	1320	5375	1220	4425	1205	20015
16	16	4840	1320	5470	1220	4425	1205	20185
17	16	4540	1320	5480	1220	4425	1205	19895
18	2	4740	1320	5270	1220	3763	1205	19170
18	3	4740	1320	5270	1220	3745	1220	19170
18	5	4740	1320	5260	1220	3910	1220	19320
18	6	4740	1320	5230	1260	4330	1245	19720
18	7	4740	1320	5101	1220	4030	1220	19271
18	8	4740	1320	5725	1240	3858	1240	19800
18	9	4740	1320	5170	1220	4560	1205	19955
18	10	4740	1320	4930	1220	4105	1205	19120
18	11	4740	1320	5090	1220	4560	1205	19840
18	12	4740	1320	5100	1220	4410	1205	19695
18	13	4740	1320	5170	1220	4555	1205	19890
18	14	4740	1320	5240	1220	4415	1205	19825
18	15	4740	1320	4975	1220	4495	1205	19600
18	16	4740	1320	5370	1220	4425	1205	19970
2	17	4240	1320	5195	1220	4410	1220	19710
4	17	4688	1325	5193	1220	4410	1220	19813

5	17	4540	1320	5185	1220	4410	1220	19995
6	17	4140	1320	5225	1220	4410	1220	19255
7	17	4150	1320	5190	1220	4410	1220	19220
8	17	4450	1320	5175	1220	4410	1220	19510
9	17	4540	1320	5080	1220	4410	1220	19525
10	17	4790	1320	5195	1220	4410	1220	19865
11	17	4440	1320	5355	1220	4410	1220	19705
12	17	4440	1320	5185	1220	4410	1220	19505
13	17	5040	1320	5185	1220	4410	1220	20115
14	17	4090	1320	5205	1220	4410	1220	19575
15	17	4790	1320	5200	1220	4410	1220	19870
16	17	4840	1320	5295	1220	4410	1220	20040
17	17	4540	1320	5305	1220	4410	1220	19750
18	17	4740	1320	5195	1220	4410	1220	19825

## Declaration

I, Laszlo Bruzsa Chief Engineer, delegate of the National Heavy Vehicle Regulator, approve this PBS Vehicle Approval PBS–V210903 –VA22459.

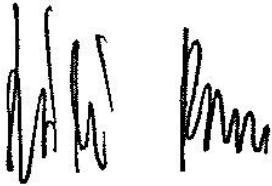

Laszlo (Les) Bruzsa  
 Chief Engineer  
 National Heavy Vehicle Regulator  
 Dated: 09/02/26

## Revision table

N	VA	Vers	Brief description	Date
1	9955	1A	First issue.	08/10/21
2	10989	1A	Adding 2x trucks, 2x trailers to VA9955 (additional VINs listed in bold).	27/04/22
3	12180	1A	Adding 2x trucks, 3x trailers to VA10989 (additional VINs listed in bold).	20/10/22
4	12713	1A	Adding 1x truck, 1x trailer to 12180 (additional VINs listed in bold).	24/01/23
5	13824	1A	Adding 1x truck, 1x trailer; Removing 2x trucks (6F500000CA447596, 6F500000BA445568), 1x trailer (6T9T24V97C0AFH097) from VA12713 (additional VINs listed in bold).	29/05/23
6	14009	1A	Adding 1x truck, 1x trailer to VA13824 (additional VINs listed in bold).	05/07/23
7	15602	1A	Adding 1x truck, 1x trailer to VA14009 (additional VINs listed in bold).	16/01/24
8	17123	1A	Adding 1x truck, 1x trailer to VA15602 (additional VINs listed in bold).	22/07/24
9	17614	1A	Adding 2x trucks, 2x trailers to VA17123 (additional VINs listed in bold).	11/09/24
10	18987	1A	Adding 2x trucks, 2x trailers to VA17614 (additional VINs listed in bold).	03/02/25
11	22459	1A	Adding 1x trailer to VA18987 (additional VINs listed in bold).	09/02/26

## General access for a specified PBS vehicle

The vehicle combinations listed in this PBS Vehicle Approval qualify for general access to the road network under the *specified PBS vehicle* provisions of the Heavy Vehicle National Law. A specified PBS vehicle must comply with all applicable requirements of Schedule 1 of the *Heavy Vehicle (Mass, Dimension and Loading) National Regulation* (HV(MDL)NR).

## Specified PBS vehicle mass limits

1. A specified vehicle's allowed mass is limited to the lesser of either the mass shown in the applicable PBS Level 1 GML Vehicle Approval mass table, or the relevant prescribed limit set in Part 1, Section 2, Schedule 1 of the HV(MDL)NR.
2. A specified vehicle's allowed mass of an axle group is limited to the lesser of either the mass shown in the applicable PBS Level 1 GML Vehicle Approval mass table, or the relevant prescribed limit set in "Table 1 – Axle mass limits table" in Schedule 1 of the HV(MDL)NR.
3. A specified vehicle's allowed mass between any two axles or axle groups is limited to the relevant prescribed limit set in "Table 2 – Axle spacing mass limits general table" in Schedule 1 of the HV(MDL)NR.

## Specified PBS vehicle operating conditions

1. When operating as a general access vehicle, a specified PBS vehicle must comply with all operating conditions of its Vehicle Approval that apply at Level 1. This includes payload heights, the drive axle mass requirement, approved tyre options and all operating conditions that do not specify a level of access.
2. The regulation includes a requirement about towing ratios. Loading and unloading must be managed so that the trailer mass does not exceed the mass of the towing vehicle.

## For more information

For more information visit our [PBS vehicle access permit page](#) under Access management.

## Disclaimer

The information on this page is general guidance only and does not constitute legal advice. Consider whether you require Independent legal advice to address your particular circumstances.

## Important information

The driver must keep in the driver's possession a copy of this Vehicle Approval and be able to produce it for inspection by compliance officers. Penalties can apply.

If changes or modifications are required, these are limited to the specifications contained in the relevant PBS Design Approval and the Application for Design Approval Part A and B. Contact the applicant (see the cover page on this document) for information related to the allowed specifications.

A change of components and/or dimensions must be certified by an approved [PBS Certifier](#) and an updated version of this Vehicle Approval must be obtained. A change of tyres, outside of the list contained on this Vehicle Approval, also requires approval but will not require an inspection by a PBS Certifier.

If VA contains multiple tyre option tables, all tyre selections must be chosen from the same tyre options table. Tyres from different tyre options tables are not interchangeable.

## Road access

The PBS Vehicle Approval is not an authorisation to access the road network. You must comply with the relevant Notice or obtain an access permit. To apply for an access permit, visit the [NHVR Portal](#).

For more information on PBS Notices visit:

[National Class 2 PBS Level 1 & 2a Truck and Dog Trailer Authorisation Notice 2021 \(No.1\)](#)

[National Class 2 Performance Based Standards \(High Productivity\) Authorisation Notice](#)

[National Class 2 Performance Based Standards \(Tier 1\) Authorisation Notice 2021](#)

If you add vehicles to your PBS Vehicle Approval, the PBS Vehicle Approval number may change depending on the new vehicles added. If the PBS Vehicle Approval number has changed, and your access permit references a PBS Vehicle Approval number, your access permit will need to be amended to reflect the latest Vehicle Approval number. Note that most truck and dog access permits will not reference a PBS Vehicle Approval number and therefore changes to the Vehicle Approval do not require an update to the access permit. For more information, watch [Adding vehicles to a PBS Vehicle Approval](#) video on our YouTube channel.

For more information, please visit our website at [www.nhvr.gov.au](http://www.nhvr.gov.au) or call 13 NHVR (13 64 87).

For queries relating to this document please contact the PBS Operations Team at [pbs@nhvr.gov.au](mailto:pbs@nhvr.gov.au).

## Manage your PBS Vehicle Approval

Please visit our [website](#) to view a list of available options and associated forms to manage your PBS Vehicle Approval.