

Accident Prevention
 Read and understand safety warning in the operation and maintenance manual
 Have you completed a take 2?
 Have your job circumstances change since completing your take 2?

14M/14H/140H 250 Hour Grader Service Sheet

Date:	28/11/25	Name:	Dion + PJ		
Plant ID:		Service Type:	250 Hour	Machine Hours:	19,257 HRS
<input checked="" type="checkbox"/>	Machine has been cleaned prior to commencement of service				
<input checked="" type="checkbox"/>	Machine has been positioned on flat level ground				
<input checked="" type="checkbox"/>	All implements have been lowered				
<input checked="" type="checkbox"/>	Machine has been isolated and locked out				

Compartment	Oil Type
Engine	15W-40
Transmission	30W
Hydraulics	10W
Radiator	Cat Extended Life Coolant
Tandem LH	30W
Tandem RH	30W
Circle Drive	85W-140
Wheel bearing	50W

Note: The electronic copy of this document is controlled. To ensure that other copies of this document are current, check the revision number and date against the compliance management database, Qudos

250HR LUBE SERVICE		INITIAL
SAMPLE:	Engine	Pm
	Transmission	Pm
CHANGE:		
	Engine oil	Pm
	Engine oil filters	Pm
	Fuel filters	Pm
	Primary air filter	Pm
CLEAN:		
	Batteries and terminals	R.
	Engine breather	R.
	Primary fuel screen	R.
	Transmission screens	R.
	Transmission and diff housing breather	R.
CHECK:		
	Daily service	R.
	Front wheel hub oil levels	R.
	Circle drive housing oil level	R.
	Tandem oil levels	R.
	Drain water from air tank	R.
	Coolant charge level	Pm
	Battery electrolyte level	R.
GREASE:		
	Fan hub bearing (hand gun only) (no mine grease)	R.
	Driveshaft splines and universal joints (hand gun only) (no mine grease)	R.
	Articulation hitch bearings	R.
NOTES:		

Note: The electronic copy of this document is controlled. To ensure that other copies of this document are current, check the revision number and date against the compliance management database, Qudos

250HR MECHANICAL SERVICE				
KEY: 1. Defect found and repaired 2. Defect found and recorded, machine still OK 3. OK 4. Not applicable				
CHECK:	1	2	3	4
Condition and tension of V belts			✓	
Universal joints for wear			✓	
Drawbar ball bush wear			✓	
Blade and circle adjustment			✓	
All blade and circle balls and bushes etc. for movement			✓	
Articulation hitch bearing for movement			✓	
Articulation cylinder pin wear			✓	
Air conditioner – condition and operation			✓	
Operation of hydraulic controls			✓	
Frame and attachments for cracks			✓	
Fuel system for loose bolts and fittings			✓	
Fuel line supply support clamps			✓	
Hydraulic system for damaged lines and loose fittings			✓	
All hoses for general condition and chaffing			✓	
Cooling system hoses for condition and clamps for tightness			✓	
Induction system for leaks and clamps for tightness			✓	
Engine and transmission mounts			✓	
Exhaust system for leaks, clamps and bolts for tightness			✓	
Radiator for debris (wash if necessary)			✓	
That all points are receiving grease			✓	
Operation of park brake interlock			✓	
Magnetic plug conditions*:	RHF(OK .)	LHF(OK .)		
*LEGEND: OK – OK P – Paste HP – Heavy Paste LF – Light Flakes HF – Heavy Flakes (return to foreman)				

Note: The electronic copy of this document is controlled. To ensure that other copies of this document are current, check the revision number and date against the compliance management database, Qudos

CHECK TYRE PRESSURES:

	POS 1	POS 2	POS 3	POS 4	POS 5	POS 6
Actual:						
Adjusted:						

SAFETY CHECK TO BE CARRIED OUT EVERY SERVICE

NOTE: Boxes A - F are to be initialled by person carrying out safety checks.

Every person carrying out these checks **must** also sign off Safety Check Sheet before the end of each shift.

KEY:

- A. **Machine is not safe**, defect must be repaired
- B. Defect found, authorisation required before returning to work
- C. Defect found and recorded, machine safe to operate
- D. Defect found and repaired
- E. OK
- F. Not applicable

CHECK:	A	B	C	D	E	F
Service Brake Operation 1. This test must be carried out on a hard dry level surface, clear of personnel and obstacles. Seat belt must be worn. 2. Start the engine and slightly raise the blade. Depress the decelerator control pedal and the service brake control pedal simultaneously. 3. Move gear to THIRD SPEED FORWARD position. Increase the engine speed to high idle. 4. Gradually release the decelerator control pedal. The machine should not move and the engine should stall. 5. Engage park brake and lower the blade to the ground.					✓	
Emergency/ Park Brake 1. This test must be carried out on a hard dry surface, clear of personnel and obstacles. Seat belt must be worn. 2. Position the machine upward on a 20 percent slope. 3. Engage the parking brake and release the service brake. The wheels should not rotate. If the wheels rotate, apply the service brake.					✓	
Steering operation					✓	
Emergency steering operation					✓	
Seat belt – retainers and operation					✓	
Horns – air/electric					✓	
Wipers					✓	
Mirrors					✓	
Seats – suspension adjustment/condition					✓	
Doors					✓	
Windows					✓	
Gauges					✓	

Note: The electronic copy of this document is controlled. To ensure that other copies of this document are current, check the revision number and date against the compliance management database, Qudos

CHECK:	A	B	C	D	E	F
Operation of shift tower					✓	
Grab rails					✓	
Fire extinguishers – invert and shake to loosen powder					✓	
Fire suppression bottle charge					✓	
Tyre condition					✓	
Lights					✓	
Reverse alarm					✓	
Wheel nuts					✓	
Cab condition					✓	
Audible alarm and warning lights					✓	
Operation of emergency stop					✓	
Steps					✓	
Pin and retainers					✓	
Accumulation of fuel, oil, grease etc. that may cause a fire hazard					✓	
Two way radio operation					✓	
Fuel leaks					✓	

Note: The electronic copy of this document is controlled. To ensure that other copies of this document are current, check the revision number and date against the compliance management database, Qudos

Prepared By: Troy Slorach Date: 31/08/2020 Approved By: Troy Slorach Date: 31/08/2020
 Rev. No: 3 Date Implemented: 31/08/2020

Accident Prevention
 Read and understand safety warning in the operation and maintenance manual
 Have you completed a take 2?
 Have your job circumstances change since completing your take 2?

14M/14H/140H 1000 Hour Grader Service Sheet

Date:	28/08/25	Name:	DION ROBERTS + PJ		
Plant ID:	1GR-51	Service Type:	1000 Hour	Machine Hours:	
<input checked="" type="checkbox"/>	Machine has been cleaned prior to commencement of service				
<input checked="" type="checkbox"/>	Machine has been positioned on flat level ground				
<input checked="" type="checkbox"/>	All implements have been lowered				
<input checked="" type="checkbox"/>	Machine has been isolated and locked out				

Compartment	Oil Type
Engine	15W-40
Transmission	30W
Hydraulics	10W
Radiator	Cat Extended Life Coolant
Tandem LH	30W
Tandem RH	30W
Circle Drive	85W-140
Wheel bearing	50W

Note: The electronic copy of this document is controlled. To ensure that other copies of this document are current, check the revision number and date against the compliance management database, Qudos

Prepared By: Troy Slorach Date: 31/08/2020 Approved By: Troy Slorach Date: 31/08/2020
 Rev. No: 2 Date Implemented: 31/08/2020

1000 HR LUBE SERVICE		INITIAL
SAMPLE:	Engine	Pur
	Transmission	Pur
	Hydraulic	Pur
CHANGE:		
	Engine oil	Pur
	Engine oil filters	Pur
	Fuel filters	Pur
	Primary air filter	Pur
	Secondary air filter	Pur
	Transmission oil	Pur
	Transmission filter	Pur
	Hydraulic filter	Pur
	P1 hub oil	Pur
	P2 hub oil	Pur
	Circle drive oil	Pur
	Cab air conditioner filters	Pur
CLEAN:		
	Batteries and terminals	Pur
	Engine breather	Pur
	Primary fuel screen	Pur
	Transmission screens	Pur
	Transmission and diff housing breather	Pur
	Pre-cleaner – Inspect and clean if necessary	Pur
CHECK:		
	Daily Service	Pur
	Tandem oil levels	Pur
	Drain water from air tank	Pur
	Coolant charge level	Pur
	Battery electrolyte level	Pur
GREASE:		
	Fan hub bearing (hand gun only) (no mine grease)	N/A
	Driveshaft splines and universal joints (hand gun only) (no mine grease)	Pur
	Articulation hitch bearings	Pur

Note: The electronic copy of this document is controlled. To ensure that other copies of this document are current, check the revision number and date against the compliance management database, Qudos

Prepared By: Troy Storch Date: 31/08/2020 Approved By: Troy Storch Date: 31/08/2020
 Rev. No: 2 Date Implemented: 31/08/2020

1000HR MECHANICAL SERVICE				
KEY:				
1. Defect found and repaired 2. Defect found and recorded, machine still OK 3. OK 4. Not applicable				
CHECK:	1	2	3	4
Condition and tension of V belts			✓	
Universal joints for wear			✓	
Drawbar ball bush wear			✓	
Blade and circle adjustment			✓	
All blade and circle balls and bushes etc. for movement			✓	
Articulation hitch bearing for movement			✓	
Articulation cylinder pin wear			✓	
Air conditioner – condition and operation			✓	
Operation of hydraulic controls			✓	
Frame and attachments for cracks			✓	
Fuel system for loose bolts and fittings			✓	
Fuel line supply support clamps			✓	
Hydraulic system for damaged lines and loose fittings			✓	
All hoses for general condition and chaffing			✓	
Cooling system hoses for condition and clamps for tightness			✓	
Induction system for leaks and clamps for tightness			✓	
Engine and transmission mounts			✓	
Exhaust system for leaks, clamps and bolts for tightness			✓	
Radiator for debris (wash if necessary)			✓	
All points are receiving grease			✓	
Operation of park brake interlock			✓	
Fan hub and jockey pullet bearings for excessive movement			✓	
Rekit air dryer			✓	
Front axle assembly for excessive pin to bush movement			✓	
Blade cushion accumulators for charge and operation			✓	
Cab mounts			✓	
Magnetic plug conditions*:	RHF(<i>ok</i>)	LHF(<i>ok</i>)		

Note: The electronic copy of this document is controlled. To ensure that other copies of this document are current, check the revision number and date against the compliance management database, Qudos

Prepared By: Troy Slorach Date: 31/08/2020 Approved By: Troy Slorach Date: 31/08/2020
 Rev. No: 2 Date Implemented: 31/08/2020

***LEGEND:**

OK – OK P – Paste HP – Heavy Paste LF – Light Flakes HF – Heavy Flakes (return to foreman)

CHECK TYRE PRESSURES:

	POS 1	POS 2	POS 3	POS 4	POS 5	POS 6
Actual:						
Adjusted:						

SAFETY CHECK TO BE CARRIED OUT EVERY SERVICE

NOTE: Boxes A - F are to be initialled by person carrying out safety checks.

Every person carrying out these checks **must** also sign off Safety Check Sheet before the end of each shift.

KEY:

- A. **Machine is not safe**, defect must be repaired
- B. Defect found, authorisation required before returning to work
- C. Defect found and recorded, machine safe to operate
- D. Defect found and repaired
- E. OK
- F. Not applicable

CHECK:	A	B	C	D	E	F
Service Brake Operation 1. This test must be carried out on a hard dry level surface, clear of personnel and obstacles. Seat belt must be worn. 2. Start the engine and slightly raise the blade. Depress the decelerator control pedal and the service brake control pedal simultaneously. 3. Move gear to THIRD SPEED FORWARD position. Increase the engine speed to high idle. 4. Gradually release the decelerator control pedal. The machine should not move and the engine should stall. 5. Engage park brake and lower the blade to the ground.					✓	
Emergency/ Park Brake 1. This test must be carried out on a hard dry surface, clear of personnel and obstacles. Seat belt must be worn. 2. Position the machine upward on a 20 percent slope. 3. Engage the parking brake and release the service brake. The wheels should not rotate. If the wheels rotate, apply the service brake.					✓	
Steering operation					✓	
Emergency steering operation					✓	
Seat belt – retainers and operation					✓	
Horns – air/electric					✓	
Wipers					✓	
Mirrors					✓	
Seats – suspension adjustment/condition					✓	

Note: The electronic copy of this document is controlled. To ensure that other copies of this document are current, check the revision number and date against the compliance management database, Qudos

Prepared By: Troy Slorach Date: 31/08/2020 Approved By: Troy Slorach Date: 31/08/2020
 Rev. No: 2 Date Implemented: 31/08/2020

CHECK:	A	B	C	D	E	F
Doors					✓	
Windows					✓	
Gauges					✓	
Operation of shift tower					✓	
Grab rails					✓	
Fire extinguishers – invert and shake to loosen powder					✓	
Fire suppression bottle charge					✓	
Tyre condition					✓	
Lights					✓	
Reverse alarm					✓	
Wheel nuts					✓	
Cab condition					✓	
Audible alarm and warning lights					✓	
Operation of emergency stop					✓	
Steps					✓	
Pin and retainers					✓	
Accumulation of fuel, oil, grease etc. that may cause fire hazard					✓	
Fuel leaks					✓	

Note: The electronic copy of this document is controlled. To ensure that other copies of this document are current, check the revision number and date against the compliance management database, Qudos

Prepared By: Troy Storch **Date:** 31/08/2020 **Approved By:** Troy Storch **Date:** 31/08/2020
Rev. No: 2 **Date Implemented:** 31/08/2020



Plant ID:	4251	Site:	Doucas	Tyre and Rim Change
Tyre Size:	7.5-5	Hours:	16613	
		Tyre Fitter:		
		Kilometres:		
		Model:	1414	
		Date:	16-5-22	

POS	Serial No.	Tread In	Tread Out	Rim No.		Make	Type	Spec	Service Code***	Removal Reason Code**	Action Code*
				In	Out						
4	F87481412	20	18			Industrene	U steel	MA11	A	10	
6	F82481102	17	15			Industrene	U steel	MA11	4	10	
Tyre - Rim On											
4	NEW			22	22			MA11			50
6	NEW			22	22			MA11			50

*Action Code		**Removal Reason Code	
A	Scrap	TCUT	Tread Rock cut & Penetration
B	Repair	IRRW	Irregular wear, spot wear, rapid wear
C	Further inspection	GBU	Ply cord/casing break up
D	Return to mine site	SCUT	Sidewalls/shoulder rock & penetration
E	Transfer to another site	BEAD	Bead burst, chaffer end separation, rim friction
F	Transfer from Supplier	FO	Foreign Object
G	Sold	ACCD	Fire, Chemical, rock ejector, loader bucket
H	Send for recap	SB	Shock burst, no evidence of rock cut
***Service Code			
A	Tyre rotation	SCK	Buttress crack, radial crack at shoulder area
B	Vehicle Maintenance	SWC	Sidewall crack
C	Due to rim problem	RO	Run out
D	Due to tyre problem	VIB	Pattern pitch vibration
E	Due to air leak	BDFT	Improper fitment
F	Tyre fitment	NA	Not applicable
G	Other reason	WO	Worn Out

Tyre and Rim Positions:

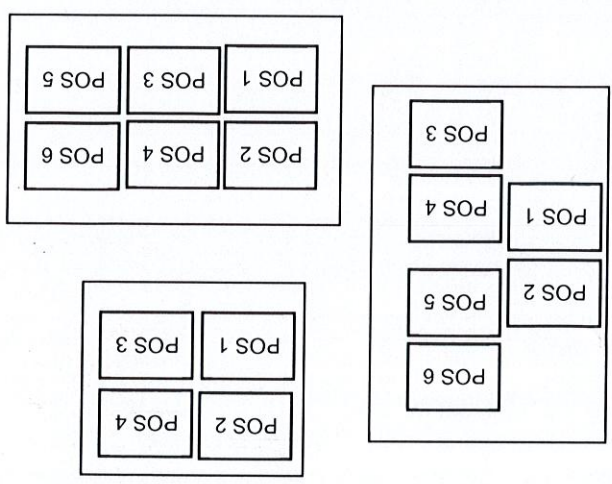

Note: The electronic copy of this document is controlled. To ensure that other copies of this document are current, check the revision number and date against the compliance management database. Qudos
 Prepared By: David McNicol Date: 03/02/2020 Approved By: John Stokes Date: 03/02/2020
 Rev. No: 2 Date Implemented: 03/02/2020

Plant ID:	GA51	Site:	Duurs	Tyre and Rim Change
Tyre Size:	20.5	Hours:	16.613	Document No. MAF0041
				Tyre and Rim Change
				Quality Form
				Integrated Management System
				GARRWAYGROUP

POS	Serial No.	Tread In	Tread Out	Rim No.	Make	Type	Spec	Service Code***	Removal Reason Code**	Action Code*
2	FM48105	21	19		DAVIDSTONE	LYREA	MAN	A	10	
5	FM48105	20	20		DAVIDSTONE	LYREA	MAN	A	10	

POS	New or Used	Serial No.	Tread In	Tread Out	Rim No.	Make	Type	Spec	Service Code***	Removal Reason Code**	Action Code*
2	NEW	XK4504814	33	33		Yokohama	AD11	MAN		50	
5	NEW	XK255SDA731	33	33		Yokohama	AD11	MAN		50	

*Action Code		**Removal Reason Code	
A	Scrap	TCUT	Tread Rock cut & Penetration
B	Repair	IRRW	Irregular wear, spot wear, rapid wear
C	Further inspection	CBU	Ply cord/casing break up
D	Return to mine site	SCUT	Sidewall/shoulder rock & penetration
E	Transfer to another site	BEAD	Bead burst, chaffer end separation, rim friction
F	Transfer from Supplier	FO	Foreign Object
G	Sold	ACCD	Fire, Chemical, rock ejector, loader bucket
H	Send for recap	SB	Shock burst, no evidence of rock cut
***Service Code			
A	Tyre rotation	SCK	Buttress crack, radial crack at shoulder area
B	Vehicle Maintenance	SWC	Sidewall crack
C	Due to rim problem	RO	Run out
D	Due to tyre problem	VIB	Pattern pitch vibration
E	Due to air leak	BDFT	Improper fitment
F	Tyre fitment	NA	Not applicable
G	Other reason	WO	Worn Out

Tyre and Rim Positions:

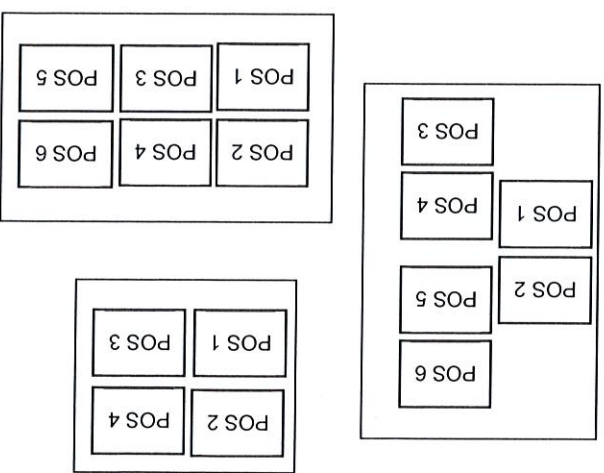

Note: The electronic copy of this document is controlled. To ensure that other copies of this document are current, check the revision number and date against the compliance management database, Qudos

Prepared By: David McNicol Date: 03/02/2020 Approved By: John Stokes Date: 03/02/2020

Rev. No: 2 Date Implemented: 03/02/2020

Date	Work Description	Plant No	Work Type
30/01/21	GR51 - oil leak	GR51	Plant Maintenance Labour
01/02/21	GR51 - grease line & blade slides	GR51	Plant Maintenance Labour
02/02/21	GR51 - grease to pins	GR51	Plant Maintenance Labour
10/02/21	SC31 - check accumulator	GR51	Plant Maintenance Labour
10/02/21	GR51 - grease line	GR51	Plant Maintenance Labour
13/02/21	GR51 - wash & demob	GR51	Plant Maintenance Labour
26/02/21	GR51 - check over machine	GR51	Plant Maintenance Labour
20/04/21	Grader Repairs	GR51	MF - Maintenance Fitter
22/04/21	Grader Repairs	GR51	MF - Maintenance Fitter
22/04/21	Remove A/C Components, Install Cab to Machine	GR51	MF - Maintenance Fitter
22/04/21	Loom + Clamps A/C Lines HYD Cylinder + Clean Up	GR51	MF - Maintenance Fitter
23/04/21	Grader Repairs	GR51	MF - Maintenance Fitter
23/04/21	Grader Repairs	GR51	MF - Maintenance Fitter
25/04/21	Repair Hydraulic Oil Leak	GR51	MF - Maintenance Fitter
26/04/21	Grader Repairs	GR51	MF - Maintenance Fitter
26/04/21	Remove + Replace A/C Lims + Brake Hoses	GR51	MF - Maintenance Fitter
26/04/21	Wire Loom, Remove Hoses	GR51	MF - Maintenance Fitter
26/04/21	Fit Fuel Tanks	GR51	MF - Maintenance Fitter
26/04/21	Final Drive Bearings, Install Fuel Tanks	GR51	MF - Maintenance Fitter
26/04/21	Clean + Puff Parts, Clean up Work Area	GR51	MF - Maintenance Fitter
27/04/21	Fit Tandems, Fit Brake Hoses	GR51	MF - Maintenance Fitter
27/04/21	Fit + Rout Brake + Accumulator Hoses	GR51	MF - Maintenance Fitter
27/04/21	Clean Up + Pressure Wash Under Grader	GR51	MF - Maintenance Fitter
27/04/21	Clean Tandem Housings, Buff Mounting Surfaces	GR51	MF - Maintenance Fitter
27/04/21	Paint Housings L/H + R/H	GR51	MF - Maintenance Fitter
27/04/21	Install Housings Torque Boats 380 FT + Lootite	GR51	MF - Maintenance Fitter
27/04/21	Clean Brake Packd Whell Groups	GR51	MF - Maintenance Fitter
27/04/21	Run, Brake Lines , Tap out Threads, Clean Parts	GR51	MF - Maintenance Fitter
28/04/21	Pick up Parts	GR51	MF - Maintenance Fitter
28/04/21	Roote A/C	GR51	MF - Maintenance Fitter
28/04/21	Install Sensors + Harness Connectors	GR51	MF - Maintenance Fitter
29/04/21	Grader Repairs	GR51	Maintenance Manager
29/04/21	Grader Repairs, Order Parts	GR51	MF - Maintenance Fitter
29/04/21	A/C Lines Accumulator Lines Clamps Clean A Frame	GR51	MF - Maintenance Fitter
30/04/21	Repairs & Painting	GR51	MF - Maintenance Fitter
30/04/21	Replace Eng Hood FE Heater Lines LH Baille AF	GR51	MF - Maintenance Fitter
05/05/21	Rebuild Grader	GR51	MF - Maintenance Fitter
05/05/21	Install Front End Axle Group	GR51	MF - Maintenance Fitter
06/05/21	Reassemble Grader	GR51	MF - Maintenance Fitter
06/05/21	Collect Parts WA-Chase uo Parts - Tandem Chains	GR51	MF - Maintenance Fitter
06/05/21	Tandem Chains Install & Assemble Grader	GR51	MF - Maintenance Fitter
07/05/21	Major Repairs	GR51	MF - Maintenance Fitter
10/05/21	Reassemble Grader	GR51	MF - Maintenance Fitter
10/05/21	Reassemble Grader	GR51	MF - Maintenance Fitter
11/05/21	Grader Repairs	GR51	MF - Maintenance Fitter
11/05/21	Grader Repairs	GR51	MF - Maintenance Fitter
11/05/21	Assemble Grader	GR51	MF - Maintenance Fitter
11/05/21	Assemble Grader, Disassemble Wheel Spindals, Clean	GR51	MF - Maintenance Fitter
12/05/21	Grader Repairs	GR51	MF - Maintenance Fitter
12/05/21	Grader Repairs	GR51	MF - Maintenance Fitter
12/05/21	Re-Build Front Wheel Spindals, Reseal Re Rale	GR51	MF - Maintenance Fitter
12/05/21	Re Bush Front Asile Groups	GR51	MF - Maintenance Fitter
13/05/21	Re-Assemble Grader	GR51	MF - Maintenance Fitter
13/05/21	Re-Assemble Grader	GR51	MF - Maintenance Fitter
14/05/21	RE-Assemble Grader	GR51	MF - Maintenance Fitter
14/05/21	Re-Assemble Grader	GR51	MF - Maintenance Fitter
26/05/21	Cut Auto Grease Plate	GR51	MF - Maintenance Fitter
27/05/21	Make Auto Grease Plate	GR51	MF - Maintenance Fitter
27/05/21	Cut out Bushes (Circle)	GR51	MF - Maintenance Fitter
27/05/21	Grader Repairs	GR51	MF - Maintenance Fitter
28/05/21	Rebuild Heater Box	GR51	MF - Maintenance Fitter

28/05/21	Install Heater Box. Assemble Cab	GR51	MF - Maintenance Fitter
31/05/21	Grader Repairs	GR51	MF - Maintenance Fitter
01/06/21	Repairs	GR51	MF - Maintenance Fitter
01/06/21	Repairs	GR51	MF - Maintenance Fitter
02/06/21	Repairs & 250hr Service	GR51	LMF - Labour Maintenance Fitter
02/06/21	Service Kit & Service	GR51	LMF - Labour Maintenance Fitter
10/06/21	Fit/Made Grease Lines	GR51	LMF - Labour Maintenance Fitter
15/06/21	Grease System Install	GR51	LMF - Labour Maintenance Fitter
17/06/21	Grease System Install	GR51	LMF - Labour Maintenance Fitter
17/06/21	Replase POS 3 Tyre O'Ring	GR51	LMF - Labour Maintenance Fitter
18/06/21	Grease System Install	GR51	LMF - Labour Maintenance Fitter
21/06/21	Cert Form GR51	GR51	MF - Maintenance Fitter
22/06/21	Retorque Wheels and Steering fault	GR51	MF - Maintenance Fitter
23/06/21	re torqued wheel nuts	GR51	MF - Maintenance Fitter
30/06/21	Tandum Chains	GR51	MF - Maintenance Fitter
30/06/21	Tandum Chains	GR51	MF - Maintenance Fitter
30/06/21	LH Tandem Chains	GR51	LMF - Labour Maintenance Fitter
01/07/21	Set and check GPS	GR51	MF - Maintenance Fitter
01/07/21	Remve boken chains and remove from pit	GR51	MF - Maintenance Fitter
02/07/21	Tandum chain repair	GR51	MF - Maintenance Fitter
05/07/21	Torque wheel and top up tandums	GR51	MF - Maintenance Fitter
12/07/21	Defects on GR51	GR51	MF - Maintenance Fitter
12/07/21	Fit arm rests	GR51	MF - Maintenance Fitter
12/07/21	Auto Greaser fault	GR51	MF - Maintenance Fitter
12/07/21	Auto Greaser Fault	GR51	MF - Maintenance Fitter
13/07/21	Grease Fault	GR51	MF - Maintenance Fitter
16/07/21	Remove old sterring valve	GR51	MF - Maintenance Fitter
16/07/21	Fit new steering valve	GR51	MF - Maintenance Fitter
21/07/21	Check for clunking noise	GR51	MF - Maintenance Fitter
21/07/21	High Hydraulic temp code	GR51	MF - Maintenance Fitter
22/07/21	Fill Grease pod - pre start machine	GR51	MF - Maintenance Fitter
22/07/21	Steer fault check pressures	GR51	MF - Maintenance Fitter
22/07/21	Steering fault	GR51	MF - Maintenance Fitter
23/07/21	Check steering and implement pressures	GR51	MF - Maintenance Fitter
23/07/21	Trouble shoot steering and implement fault	GR51	MF - Maintenance Fitter
23/07/21	Steering fault	GR51	MF - Maintenance Fitter
03/08/21	Service	GR51	MF - Maintenance Fitter
03/08/21	Service	GR51	MF - Maintenance Fitter
03/08/21	Implement Valve repairs	GR51	MF - Maintenance Fitter
03/08/21	hydraulic fault	GR51	MF - Maintenance Fitter
04/08/21	reseal- refit implement valve	GR51	MF - Maintenance Fitter
04/08/21	Check and set hydraulic pressures	GR51	MF - Maintenance Fitter
04/08/21	Check for hydraulic systems over heating	GR51	MF - Maintenance Fitter
04/08/21	Hydraulic fault	GR51	MF - Maintenance Fitter
05/08/21	Fit Panels and guards	GR51	MF - Maintenance Fitter
05/08/21	Fault code low hydraulic pressure	GR51	MF - Maintenance Fitter
23/08/21	Bulk Grease/ check grease	GR51	MF - Maintenance Fitter
27/08/21	Helped Lift Cab off GR51	GR51	MF - Maintenance Fitter
27/08/21	Defects GR51	GR51	MF - Maintenance Fitter
27/08/21	Hydraulic repairs GR51	GR51	MF - Maintenance Fitter
30/08/21	Defects	GR51	MF - Maintenance Fitter
30/08/21	Hydraulic pump replacement	GR51	MF - Maintenance Fitter
30/08/21	Hydraulic repairs	GR51	MC - Maintenance Co-Ordinator
31/08/21	Clean up Greader	GR51	MF - Maintenance Fitter
31/08/21	Hydraulic pump, star up and check pressures	GR51	MC - Maintenance Co-Ordinator
09/09/21	Top up coolant	GR51	MC - Maintenance Co-Ordinator
17/09/21	Grader Defects	GR51	MF - Maintenance Fitter
29/09/21	New blades	GR51	MF - Maintenance Fitter
29/09/21	Change blade edges	GR51	MC - Maintenance Co-Ordinator
12/10/21	250hr service	GR51	MF - Maintenance Fitter
12/10/21	250 hr service/ parts pick up	GR51	MC - Maintenance Co-Ordinator
05/11/21	Grader repairs- 1,6,7 gears and n o reverse	GR51	MC - Maintenance Co-Ordinator

08/11/21	Drive fault	GR51	MC - Maintenance Co-Ordinator
09/11/21	Transmission fault	GR51	MF - Maintenance Fitter
16/11/21	Bulk Grease	GR51	MF - Maintenance Fitter
03/12/21	oil leak	GR51	MF - Maintenance Fitter
06/12/21	1000hr service	GR51	MF - Maintenance Fitter
06/12/21	1000hr service	GR51	MF - Maintenance Fitter
06/12/21	1000 hr service	GR51	MC - Maintenance Co-Ordinator
09/12/21	Replace steel pipe	GR51	MF - Maintenance Fitter
21/12/21	Remove steel from tyre	GR51	MF - Maintenance Fitter
10/01/22	Getting hot	GR51	MF - Maintenance Fitter
10/01/22	Engine/ Hydraulics over heating	GR51	MC - Maintenance Co-Ordinator
11/01/22	Clean out radiators	GR51	MC - Maintenance Co-Ordinator
17/01/22	Jump Start	GR51	MF - Maintenance Fitter
18/01/22	fuel hose/ battery	GR51	MF - Maintenance Fitter
18/01/22	c/o batteries	GR51	MC - Maintenance Co-Ordinator
19/01/22	Hose repairs	GR51	MF - Maintenance Fitter
19/01/22	C/o batteries	GR51	MC - Maintenance Co-Ordinator
22/02/22	250hr service	GR51	MF - Maintenance Fitter
22/02/22	Check over circle and blade list defects	GR51	MF - Maintenance Fitter
01/03/22	Wash blade +circle area c/o blade slides	GR51	MF - Maintenance Fitter
01/03/22	Blade slides	GR51	MF - Maintenance Fitter
21/03/22	Cutting edges	GR51	MF - Maintenance Fitter
21/03/22	Check GPS	GR51	MF - Maintenance Fitter
21/03/22	Cutting edges	GR51	MC - Maintenance Co-Ordinator
01/04/22	500hr service	GR51	MF - Maintenance Fitter
01/04/22	500 service	GR51	MF - Maintenance Fitter
01/04/22	500hr service	GR51	MC - Maintenance Co-Ordinator
04/04/22	Complete service and movement checks	GR51	MF - Maintenance Fitter
04/04/22	Service	GR51	MF - Maintenance Fitter
04/04/22	Complete service and defects	GR51	MC - Maintenance Co-Ordinator
13/04/22	C/O broken window	GR51	MF - Maintenance Fitter
13/04/22	Cracked window	GR51	MC - Maintenance Co-Ordinator
21/04/22	C/O drive set outside shims	GR51	MF - Maintenance Fitter
21/04/22	Reshim top shims and lube circle	GR51	MF - Maintenance Fitter
21/04/22	Circle adjustment	GR51	MF - Maintenance Fitter
21/04/22	Circle drive shim	GR51	MC - Maintenance Co-Ordinator
29/04/22	C/o RH door glass	GR51	MF - Maintenance Fitter
29/04/22	Door window	GR51	MF - Maintenance Fitter
29/04/22	Clean up scraper for repairs	GR51	MC - Maintenance Co-Ordinator
06/05/22	Check noise in tandems	GR51	MF - Maintenance Fitter
06/05/22	Rectify grease fault	GR51	MF - Maintenance Fitter
06/05/22	Tandem chain noise	GR51	MF - Maintenance Fitter
06/05/22	Auto Greaser fault	GR51	MF - Maintenance Fitter
06/05/22	Grease system	GR51	MC - Maintenance Co-Ordinator
16/05/22	C/O Pos 4/6 tyres	GR51	MF - Maintenance Fitter
16/05/22	Tyres P4+P6	GR51	MF - Maintenance Fitter
16/05/22	Tyres change out	GR51	MC - Maintenance Co-Ordinator
17/05/22	C/O Pos 3 and 5 Tyres	GR51	MF - Maintenance Fitter
17/05/22	P3 and P5 tyres	GR51	MF - Maintenance Fitter
17/05/22	Change Tyres	GR51	MC - Maintenance Co-Ordinator
18/05/22	Inspect Trans oil leak/ check levels/ parts list	GR51	MF - Maintenance Fitter
02/06/22	Ripper boots CO	GR51	MF - Maintenance Fitter
28/06/22	Remove cylinder	GR51	MF - Maintenance Fitter
29/06/22	Overhaul Cylinder	GR51	LMF - Labour Maintenance Fitter
30/06/22	Signage & Wash up	GR51	LMF - Labour Maintenance Fitter
01/07/22	Repairs & Heat Shield. Trres	GR51	LMF - Labour Maintenance Fitter
04/07/22	Prepare for Work	GR51	LMF - Labour Maintenance Fitter
14/09/22	Wash & Check Over for Mobilisation	GR51	LMF - Labour Maintenance Fitter
15/09/22	Repairs	GR51	LMF - Labour Maintenance Fitter
15/09/22	Fix GPS Pole & Clean out Belly Guards & Pans	GR51	LMF - Labour Maintenance Fitter
11/10/22	Repair Wiring of Steer Cylinder	GR51	LMF - Labour Maintenance Fitter
11/10/22	Grader Wiring	GR51	LMF - Labour Maintenance Fitter

24/10/22	Ordered bolts for fuse box	GR51	LMF - Labour Maintenance Fitter
25/10/22	Fitted new clips fitted fuse box pannel	GR51	LMF - Labour Maintenance Fitter
11/11/22	Fix oil plate on side of engine	GR51	LMF - Labour Maintenance Fitter
14/11/22	Adj/inspect circle, check over grader	GR51	LMF - Labour Maintenance Fitter
24/11/22	Fixed blown grease lines	GR51	LMF - Labour Maintenance Fitter
29/11/22	Secure hyd hoses, rpr grease line	GR51	LMF - Labour Maintenance Fitter
05/12/22	Rpl cutting edges, gps cable, circle petentiometer	GR51	LMF - Labour Maintenance Fitter
05/12/22	Rpl O-Ring	GR51	LMF - Labour Maintenance Fitter
05/12/22	Fit GPS swivel	GR51	LMF - Labour Maintenance Fitter
08/12/22	Replace grease nipples	GR51	LMF - Labour Maintenance Fitter
14/12/22	Rep grease line, hose leak, fill auto greaser	GR51	LMF - Labour Maintenance Fitter
14/12/22	Fix grease hose	GR51	LMF - Labour Maintenance Fitter
17/12/22	1000HR Service	GR51	LMF - Labour Maintenance Fitter
09/01/23	Wash out radiator and engine bay	GR51	LMF - Labour Maintenance Fitter
11/01/23	Take samplesx3, rem eng oil filter, repair ram lea	GR51	LMF - Labour Maintenance Fitter
13/01/23	Adj fan speed, used tech gun of fan	GR51	LMF - Labour Maintenance Fitter
13/01/23	Diagnosed overheating fault adj fan speed	GR51	LMF - Labour Maintenance Fitter
20/01/23	Charged Fire Suppression	GR51	LMF - Labour Maintenance Fitter
24/01/23	Repari grease line	GR51	LMF - Labour Maintenance Fitter
27/01/23	Chenge out joystick control switches	GR51	LMF - Labour Maintenance Fitter
31/01/23	AFFF repairs	GR51	LMF - Labour Maintenance Fitter
10/02/23	Fit RHS step	GR51	LMF - Labour Maintenance Fitter
13/02/23	Unload and cert form	GR51	MF - Maintenance Fitter
20/02/23	250hr service	GR51	MF - Maintenance Fitter
20/02/23	Service	GR51	MF - Maintenance Fitter
21/02/23	Complete 250 hr service	GR51	MF - Maintenance Fitter
21/02/23	C/o Cutting edges	GR51	MF - Maintenance Fitter
21/02/23	GET	GR51	MF - Maintenance Fitter
01/03/23	Attempt broken bolt form blade slide cylinder brac	GR51	MF - Maintenance Fitter
02/03/23	C/o Steering position Fault	GR51	MF - Maintenance Fitter
10/03/23	Inspect blade slide fault/ broken bolt	GR51	MF - Maintenance Fitter
14/03/23	Remove bracket for blade slide	GR51	MF - Maintenance Fitter
18/04/23	500hr service/ drain tandems due to contamination	GR51	MF - Maintenance Fitter
19/04/23	Drop belly guard remove trans suction c/o hose	GR51	MF - Maintenance Fitter
19/04/23	Fit up hose/ fill trans run up GET levels	GR51	MF - Maintenance Fitter
28/04/23	Complete 500hr service engine west side/sheet	GR51	MF - Maintenance Fitter
01/05/23	Sort parts	GR51	MF - Maintenance Fitter
02/05/23	Wash machine, C/O circle repairs	GR51	MF - Maintenance Fitter
02/05/23	Measure top rear plates, pdre shims needed	GR51	MF - Maintenance Fitter
02/05/23	Clean machine circle adjustments	GR51	MF - Maintenance Fitter
03/05/23	Shim top wear plates on circle/ adjus	GR51	MF - Maintenance Fitter
03/05/23	Shim top plates on circle	GR51	MF - Maintenance Fitter
03/05/23	Adjust side plates on circle	GR51	MF - Maintenance Fitter
23/08/23	Inspect machine	GR51	MF - Maintenance Fitter
23/08/23	Reverse light, trans oil leak	GR51	MF - Maintenance Fitter
23/08/23	LH steer cylinder pin/ bearing	GR51	MF - Maintenance Fitter
24/08/23	LH steer cylinder pin and bearing	GR51	MF - Maintenance Fitter
01/11/23	AC repairs	GR51	MF - Maintenance Fitter
13/11/23	Blade cutting edges	GR51	MF - Maintenance Fitter
13/11/23	Inspect brakes/ engine vibration	GR51	MF - Maintenance Fitter
13/11/23	Replace cutting edge	GR51	MF - Maintenance Fitter
15/11/23	Inspect steering fault	GR51	MF - Maintenance Fitter
29/11/23	250hr service	GR51	MF - Maintenance Fitter
29/11/23	Service	GR51	MF - Maintenance Fitter
30/11/23	Pressure Wash engine, radiator	GR51	MF - Maintenance Fitter
07/12/23	Check Power supplies to radios and camera	GR51	MF - Maintenance Fitter
11/12/23	Defects, inverter	GR51	MF - Maintenance Fitter
16/01/24	Fault codes- repair air filter	GR51	MF - Maintenance Fitter
29/01/24	Troubleshoot fault code, inspect R/H door motor,	GR51	MF - Maintenance Fitter
31/01/24	Fault codes/ oil leaks	GR51	MC - Maintenance Co-Ordinator
31/01/24	Fault code, engine underspeed, hyd oil leak	GR51	MF - Maintenance Fitter
31/01/24	Dash cam footage	GR51	MF - Maintenance Fitter

31/01/24	Repair new grease lines/ wash/ secondary steer hos	GR51	MF - Maintenance Fitter
01/02/24	Steering hose- secondary	GR51	MF - Maintenance Fitter
01/02/24	Trans hose	GR51	MF - Maintenance Fitter
01/02/24	Wash	GR51	MF - Maintenance Fitter
01/02/24	transmission hose	GR51	MF - Maintenance Fitter
02/02/24	Transmission hose- top up transmission oil	GR51	MF - Maintenance Fitter
02/02/24	Trans hose re assemble, test filter for restriction	GR51	MF - Maintenance Fitter
05/02/24	Defects, clogged air filter fault	GR51	MF - Maintenance Fitter
07/02/24	Troubleshoot filter restriction fault, rewire turbo	GR51	MF - Maintenance Fitter
16/02/24	Replace RH door wiper and motor/ arm	GR51	MF - Maintenance Fitter
22/02/24	Blown hose	GR51	MC - Maintenance Co-Ordinator
23/02/24	Hydraulic hose	GR51	MF - Maintenance Fitter
23/02/24	Hydraulic hose/ Fuel hose	GR51	MF - Maintenance Fitter
26/02/24	assist hydraulic and fuel hose	GR51	MF - Maintenance Fitter
26/02/24	Hydraulic hose/ fuel hose	GR51	MF - Maintenance Fitter
01/03/24	Wash out radiator- Pit 10	GR51	MF - Maintenance Fitter
02/04/24	2000hr service	GR51	MF - Maintenance Fitter
02/04/24	2000hr service	GR51	MF - Maintenance Fitter
03/04/24	2000hr service	GR51	MF - Maintenance Fitter
03/04/24	2000hr service	GR51	MF - Maintenance Fitter
09/04/24	Door seals	GR51	MC - Maintenance Co-Ordinator
16/04/24	Replace GPS Sensor	GR51	MF - Maintenance Fitter
16/04/24	Check over	GR51	MF - Maintenance Fitter
16/04/24	Inspection	GR51	MC - Maintenance Co-Ordinator
18/04/24	Defect repairs	GR51	MF - Maintenance Fitter
18/04/24	Wash and replace hoses	GR51	MF - Maintenance Fitter
18/04/24	Inspection/ defect repairs	GR51	MC - Maintenance Co-Ordinator
19/04/24	Defect repairs	GR51	MF - Maintenance Fitter
19/04/24	Defect repairs	GR51	MC - Maintenance Co-Ordinator
22/04/24	Assist with window refit	GR51	MF - Maintenance Fitter
22/04/24	Repairs to artic hoses	GR51	MC - Maintenance Co-Ordinator
23/04/24	Replace Artic hoses	GR51	MC - Maintenance Co-Ordinator
03/06/24	Check over, wash, risk assesments, oder parts	GR51	MF - Maintenance Fitter
03/06/24	Wash/ Prep GET removal	GR51	MF - Maintenance Fitter
04/06/24	Cutting edges, overlays, cert form, noise test, de	GR51	MF - Maintenance Fitter
13/06/24	Repair beacon wiring	GR51	MC - Maintenance Co-Ordinator
02/07/24	Steering cylinder leak	GR51	MC - Maintenance Co-Ordinator
08/07/24	Replace reverse light globes	GR51	MF - Maintenance Fitter
12/08/24	Steer cyclinder hyd oil leak	GR51	MC - Maintenance Co-Ordinator
13/08/24	Check over, top up fluid levels	GR51	MC - Maintenance Co-Ordinator
27/08/24	Inspect	GR51	MF - Maintenance Fitter
30/08/24	250hr service	GR51	MF - Maintenance Fitter
04/09/24	Inspect blade slides	GR51	MF - Maintenance Fitter
06/09/24	Inspect machine/ circle drive and blade slides	GR51	MF - Maintenance Fitter
09/09/24	Replace/adjust blade slides, repair retainers	GR51	MF - Maintenance Fitter
10/10/24	Steering fault, warning light emergency steer	GR51	MF - Maintenance Fitter
31/10/24	GET inspection	GR51	MF - Maintenance Fitter
01/11/24	GetR & R	GR51	MF - Maintenance Fitter
15/11/24	replace ripper boots/ had cut old boots off	GR51	MF - Maintenance Fitter
02/12/24	Diagnose wiring issue	GR51	MF - Maintenance Fitter
03/12/24	Electrical fault troubleshoot	GR51	MF - Maintenance Fitter
03/12/24	Electrical fault/ repair and test	GR51	MF - Maintenance Fitter
04/12/24	Wiring fault- move and test	GR51	MF - Maintenance Fitter
05/12/24	wiring fault troubleshoot	GR51	MF - Maintenance Fitter
05/12/24	Wiring fault	GR51	MF - Maintenance Fitter
06/12/24	Electrical fault, earth	GR51	MF - Maintenance Fitter
06/12/24	Elec fault, repaired and refit panels, test	GR51	MF - Maintenance Fitter
09/01/25	Start fault	GR51	MF - Maintenance Fitter
09/01/25	Non Start	GR51	MF - Maintenance Fitter
09/01/25	Diagnose	GR51	MF - Maintenance Fitter
09/01/25	Repair	GR51	MF - Maintenance Fitter
14/01/25	Perform 500hr service	GR51	MF - Maintenance Fitter

14/01/25	500hr service	GR51	MF - Maintenance Fitter
20/01/25	Grease defect (system repairs)	GR51	MF - Maintenance Fitter
30/01/25	Fabrication plate for GPS	GR51	MF - Maintenance Fitter
30/01/25	Top con poison sensor fault repair	GR51	MF - Maintenance Fitter
06/02/25	T fittings in artic point	GR51	MF - Maintenance Fitter
13/02/25	Replace circle topcon sensor/ calibrate	GR51	MF - Maintenance Fitter
28/02/25	GET blades	GR51	MF - Maintenance Fitter
16/04/25	Troubleshoot steer fault,	GR51	MF - Maintenance Fitter
17/04/25	Troubleshoot fault code	GR51	MF - Maintenance Fitter
23/04/25	Install ripper switch, top up coolant, tyre pressu	GR51	MF - Maintenance Fitter
13/05/25	Troubleshoot wiring fault	GR51	MF - Maintenance Fitter
13/05/25	Replace RH joystickm callibrate and test	GR51	MC - Maintenance Co-Ordinator
13/05/25	Troubleshoot 10v sensore supply fault	GR51	MF - Maintenance Fitter
14/05/25	Troubleshoot 10v supply fault- insulate harness	GR51	MF - Maintenance Fitter
20/05/25	Steer fault	GR51	MF - Maintenance Fitter
02/06/25	G.E.T	GR51	MF - Maintenance Fitter
03/06/25	Oil leak	GR51	MF - Maintenance Fitter
23/06/25	Adjust door hinges, re route harness	GR51	MF - Maintenance Fitter
24/06/25	Steering fault, 10vlt supply fault	GR51	MF - Maintenance Fitter
25/06/25	Electrical fault	GR51	MF - Maintenance Fitter
01/07/25	Electrical fault	GR51	MF - Maintenance Fitter
11/08/25	Change over GPS, screen mount	GR51	MF - Maintenance Fitter
25/08/25	GPS pole repairs	GR51	MF - Maintenance Fitter
25/08/25	Electrical fault	GR51	MF - Maintenance Fitter
28/08/25	Perform 1000hr service	GR51	MF - Maintenance Fitter
28/08/25	1000hr service	GR51	MF - Maintenance Fitter
28/08/25	Electrical fault diagnose	GR51	MF - Maintenance Fitter
01/09/25	Electrical fault/ remove wiring harness and repair	GR51	MF - Maintenance Fitter
02/09/25	Wiring fault	GR51	MF - Maintenance Fitter
02/09/25	Refit harness and scan clear codes- test	GR51	MF - Maintenance Fitter
05/09/25	Inspection and defects	GR51	MF - Maintenance Fitter
12/09/25	C/O ripper teeth and shim A frame ball	GR51	MF - Maintenance Fitter
15/09/25	Hydraulic oil leak, source parts	GR51	MF - Maintenance Fitter
15/09/25	Hydraulic hose	GR51	MF - Maintenance Fitter
15/09/25	Locate blown hose	GR51	MF - Maintenance Fitter
16/09/25	remove hydraulic line	GR51	MF - Maintenance Fitter
16/09/25	Bring parts from Horsham	GR51	MF - Maintenance Fitter
16/09/25	Remove and replace hose/ washdown machine	GR51	MF - Maintenance Fitter
19/09/25	Repair circuit and blade slides	GR51	MF - Maintenance Fitter
19/09/25	Repair brokenbolt on side shift ram	GR51	MF - Maintenance Fitter
22/09/25	A Frame ball	GR51	MF - Maintenance Fitter
22/09/25	Remove Broken bolts	GR51	MF - Maintenance Fitter
22/09/25	A frame ball remove broken bolts	GR51	MF - Maintenance Fitter
24/09/25	A frame	GR51	MF - Maintenance Fitter
25/09/25	A Frame ball rebuild and return to work	GR51	MF - Maintenance Fitter
01/10/25	Inspect Seat	GR51	MF - Maintenance Fitter
01/10/25	Seat inspection	GR51	MF - Maintenance Fitter
01/10/25	Seat Repairs	GR51	MF - Maintenance Fitter
13/10/25	Check over blade slides, circle	GR51	MF - Maintenance Fitter
17/10/25	Change out G.E.T	GR51	MF - Maintenance Fitter
27/10/25	Check Circle adjustment	GR51	MF - Maintenance Fitter
11/11/25	G.E.T C/O	GR51	MF - Maintenance Fitter
13/11/25	Coolant leak	GR51	MF - Maintenance Fitter
20/11/25	GPS pole repairs	GR51	MF - Maintenance Fitter
21/11/25	Inspection replace fan belt	GR51	MF - Maintenance Fitter
28/11/25	250hr service	GR51	MF - Maintenance Fitter
28/11/25	Service	GR51	MF - Maintenance Fitter
01/12/25	Circle adjustment	GR51	MF - Maintenance Fitter
01/12/25	Circle shimming/ defects	GR51	MF - Maintenance Fitter
04/12/25	Wash/ clean out Radiator/ top up coolant	GR51	MF - Maintenance Fitter
15/12/25	Machine defects, rotarty sensor	GR51	MF - Maintenance Fitter
15/12/25	Replace top con and circule sensor cap	GR51	MF - Maintenance Fitter

	GR51- GPS fault		
	GR51- Clean out Radiator and coolers		
	GR51- Clean out coolers		
	GR51- Clean out radiators and coolers, Machine defects		
	GR51- Tyre pressures/ Inspect machine		
	GR51 CAT 14M Grader - Service Schedule Step 500 (126)		
	GR51- Diagnose starter motor fault.		
	GR51 - Change Out Starter Motor		
	GR51- Batteries		
	GR51- Change out G.E.T		
	GR51 - Blade slide shim missing R/H side		
	GR51- Blade Slides		
	GR51- Replace ripper boots		
	GR51- GPS fault		
	GR51- C/O GPS Rotar sensor		
	GR51- C/O Rotary GPS sensor		
	GR51- Wash and demobe ready for off site		
	GR51 -Inspect and maintain transmission oil leak		