

Accident Prevention			
Read and understand safety warning in the operation and maintenance manual			
Have you completed a take 2?			
Have your job circumstances change since completing your take 2?			
SC09 627 Scraper 500 Hour Service Sheet			
Date:	26/8/25	Name:	Dion & PJ
Service Type:	500 Hour	Tractor Serial No.	DBD00838
Machine Hours:	18517	Trailer Serial No.	DBZ00838
<input checked="" type="checkbox"/>	Machine has been cleaned prior to commencement of service?		
<input checked="" type="checkbox"/>	Machine has been positioned on flat level ground		
<input checked="" type="checkbox"/>	All implements have been lowered		
<input checked="" type="checkbox"/>	Machine has been isolated and locked out		

<u>Tractor</u>		
Compartment	Oil Type	Amounts (Litres)
Engine	15W-40	38 Litres
Filter List	Qty	Part Number
Engine Oil Filter	1	1R-1808
Primary Air Filter	1	6I-2507
Fuel Filter	1	1R-0762
Fuel Water Separator	1	326-1643
Cab Air Filter	1	268-6704
Cab Air Filter	1	259-3222
Scheduled Oil Sample	8	SOS003
Coolant Sample	1	SOS004
Hydraulic Oil Filter	2	1R-0732
Transmission Filter	1	1R-0773

<u>Trailer</u>		
Compartment	Oil Type	Amount (Litres)
Engine	15W-40	30 Litres
Filter List	Qty	Part Number
Engine Oil Filter	1	1R-1808
Primary Air Filter	1	6I-0274
Fuel Filter	1	1R-0762
Fuel Water Separator	1	326-1644
Scheduled Oil Sample	8	SOS003
Coolant Sample	1	SOS004
Transmission Oil Filter	1	343-4464

Note: The electronic copy of this document is controlled. To ensure that other copies of this document are current, check the revision number and date against the compliance management database, Qudos

Prepared By: Troy Slorach Date: 31/08/2020 Approved By: Troy Slorach Date: 31/08/2020
 Rev. No: 1 Date Implemented: 31/08/2020

500HR LUBE SERVICE - TRACTOR		INITIALS
SAMPLE:	Engine	Pm
	Transmission	Pm
	Differential	Pm
	Hydraulic	
	Coolant	
	Final drive P1	Pm
	Final drive P2	Pm
	Final drive P3	Pm
	Final drive P4	Pm
CHANGE:		
	Engine oil	Pm
	Engine oil filter	Pm
	Primary air filter	Pm
	Fuel filter	Pm
	Cab air conditioner filters	Pm
	Fuel water separator	Pm
	Hydraulic oil filter	Pm
	Transmission oil filter	Pm
CLEAN:		
	Transmission screens	Pm
	Primary fuel screen	Pm
	Radiator and air conditioner condenser	Pm
	Batteries, terminals and battery box	Pm
	Air conditioner evaporator	Pm
	Torque converter scavenge screen	Pm
	Drain water from air tanks	Pm
	Drain water and sediment from fuel tank	Pm
CHECK:		
	Coolant level	Pm
	Hydraulic oil level	Pm
	Differential oil level	Pm
	Final drive oil levels	Pm
	Transmission oil levels	Pm

Note: The electronic copy of this document is controlled. To ensure that other copies of this document are current, check the revision number and date against the compliance management database, Qudos

Prepared By: Troy Slorach Date: 31/08/2020 Approved By: Troy Slorach Date: 31/08/2020
 Rev. No: 1 Date Implemented: 31/08/2020

MAGNETIC PLUGS (If applicable) :							
OK – OK	P- PASTE		P1	P2	P3	P4	
HP – HEAVY PASTE	LF – LIGHT FLAKES	HF – HEAVY FLAKES	OK	OK	P		OK

GREASE:		INITIALS
	Check cushion hitch accumulator pressure	K
	Fill bulk grease tank	K
	Ejector floor rollers	K
	Slack adjuster and brake S cams	K
	All pins receiving grease	K

500HR LUBE SERVICE - TRAILER

SAMPLE:		INITIALS
	Engine	K
	Transmission	K
	Differential	K
	Coolant	K
	Final drive P1	K
	Final drive P2	K
	Final drive P3	K
	Final drive P4	K

CHANGE:		INITIALS
	Engine oil	K
	Engine oil filters	K
	Primary air filters	K
	Fuel filters	K
	Fuel Water Separator	K
	Transmission Filter	K

CLEAN:		INITIALS
	Transmission screens	K
	Primary fuel screen	K
	Radiator air conditioner condenser	K
	Batteries and terminals	K

Note: The electronic copy of this document is controlled. To ensure that other copies of this document are current, check the revision number and date against the compliance management database, Qudos

Prepared By: Troy Slorach Date: 31/08/2020 Approved By: Troy Slorach Date: 31/08/2020
 Rev. No: 1 Date Implemented: 31/08/2020

CLEAN:		
	Torque converter scavenge screen	K
	Drop box scavenge screen	K
	Drain water from air tanks	K
	Drain water and sediment from fuel tank	K
CHECK:		
	Coolant level	K
	Transmission oil levels	K
	Differential oil levels	K
	Final drive oil levels	K

GREASE:		INITIALS
	Rear brake actuators and S cams	K
	All pins receiving grease	K

500 HR MECHANICAL SERVICE	
<ol style="list-style-type: none"> 1. Machine is not safe, defect must be repaired 2. Defect found and recorded, machine safe to operate 3. Defect found and repaired 4. OK 5. Not applicable 	

CHECK:	1	2	3	4	5
Air conditioner – condition and operation			/		
Check and clear ECM faults			/		
Engine mount bolt torque			/		
No visible oil leaks			/		
Steering pump mount bolt torque			/		
Hydraulic pump mount bolt torque			/		
Steering (cylinders, valve and joints)			/		
Induction system for leaks and clamps for tightness			/		
Check cabin, dash screws, pedal rubber etc.			/		
All hoses for general condition and chaffing			/		
Fuel system for loose bolts and fittings			/		
Fuel line pipe support clamps			/		
Hydraulic system for damaged lines and loose fittings			/		

Note: The electronic copy of this document is controlled. To ensure that other copies of this document are current, check the revision number and date against the compliance management database, Qudos

Prepared By: Troy Slorach Date: 31/08/2020 Approved By: Troy Slorach Date: 31/08/2020
 Rev. No: 1 Date Implemented: 31/08/2020

CHECK:	1	2	3	4	5
Engine mounts			✓		
Transmission and diff mount bolts			✓		
All panels and guards			✓		
Exhaust leaks			✓		
Frame for cracks – record on inspection sheet			✓		
Retarder lever free play			✓		
Remove covers and inspect brake linings			✓		
Inspect fan and jockey pulley bearings			✓		
Condition and tension of V belts / multi rib belts			✓		
Radiator for debris (wash if necessary)			✓		
Cooling system hoses for condition and clamps for tightness			✓		
Battery hold down clamps			✓		
All points are receiving grease			✓		
Check system voltages			✓		
Inspect steering column mounting bracket welds			✓		
Remove apron cylinder rod-end pin and inspect rod-end bearing			✓		

CHECK: Tyre pressures					
P1	RADIAL	75PSI	P2	RADIAL	75PSI
SPEC:	NYLON	70PSI	SPEC:	NYLON	70PSI
P1	RADIAL	75PSI	P2	RADIAL	75PSI
ACTUAL:	NYLON		ACTUAL:	NYLON	
P3	RADIAL	70PSI	P4	RADIAL	70PSI
SPEC:	NYLON	70PSI	SPEC:	NYLON	70PSI
P3	RADIAL	70PSI	P4	RADIAL	70PSI
ACTUAL:	NYLON		ACTUAL:	NYLON	

Note: The electronic copy of this document is controlled. To ensure that other copies of this document are current, check the revision number and date against the compliance management database, Qudos

Prepared By: Troy Slorach Date: 31/08/2020 Approved By: Troy Slorach Date: 31/08/2020
 Rev. No: 1 Date Implemented: 31/08/2020

SAFETY CHECK TO BE CARRIED OUT EVERY SERVICE

NOTE: Boxes A - F are to be initialled by person carrying out safety checks.

Every person carrying out these checks **must** also sign off Safety Check Sheet before the end of each shift.

KEY:

- 1.** Machine is not safe, defect must be repaired
- 2.** Defect found and recorded, machine safe to operate
- 3.** Defect found and repaired
- 4.** OK
- 5.** Not applicable

CHECK:	1	2	3	4	5
Service brake operation stall test			✓		
Emergency brake			✓		
Park brake operation			✓		
Retarder operation			✓		
Steering operation			✓		
Seats – suspension adjustment/condition			✓		
Seat belt – retainers and operation			✓		
Doors			✓		
Windows			✓		
Mirrors			✓		
Cab conditions			✓		
Horns – air and electric			✓		
Wipers			✓		
Washer bottle full			✓		
Gauges			✓		
Audible alarm and warning lights			✓		
Lights			✓		
Reverse alarm			✓		
Operation of emergency stops			✓		
Two way radio operation			✓		
Grab rails			✓		
Steps			✓		

Note: The electronic copy of this document is controlled. To ensure that other copies of this document are current, check the revision number and date against the compliance management database, Qudos

Prepared By: Troy Slorach Date: 31/08/2020 Approved By: Troy Slorach Date: 31/08/2020
 Rev. No: 1 Date Implemented: 31/08/2020

PLANT AND EQUIPMENT MAINTENANCE AND REPAIR REPORT			
Date:	27-6-22		
Plant:	Scog		
Plant No:	4		
Location:	Douglas		
Machine Hours:	15,972		
Details of Work:	CHANGE REAR TRANS COOLER		
	SUSPECT COOLANT IN TRANS OIL		
Report Completed By:	MAT ABENETHY		
Signature:		Date:	27-6-22

Note: The electronic copy of this document is controlled. To ensure that other copies of this document are current, check the revision number and date against the compliance management database, Qudos



PLANT AND EQUIPMENT MAINTENANCE AND REPAIR REPORT

Date:

28/10/21

Plant:

3009 CAT 627G

Plant No:

Location:

Kulwix.

Machine Hours:

15615 HRS.

Details of Work:

* RE-SEALED RH bowl cyl.
+ NEW pins + BEARINGS. (GE)

* RE-SEALED RH STEER cyl. (GE)

Report Completed By:

Dann Bradbrook.

Signature:

Date:

29/10/21

Note: The electronic copy of this document is controlled. To ensure that other copies of this document are current, check the revision number and date against the compliance management database, Qudos

Prepared By: Julia Crook

Date: 19/03/2015

Approved By: John Stokes

Date: 07/08/2015

Rev. No: 3

Date Implemented: 07/08/2015

Tyre and Rim Change					
Plant ID:	SC09	Site:	Kuluw	Tyre Fitter:	Model:
Tyre Size:	3325R29	Hours:		Kilometres:	6276
					Date: 1/2/21

Tyre - Rim Off										
POS	Serial No.	Tread In	Tread Out	Rim No.	Make	Type	Spec	Service Code***	Removal Reason Code**	Action Code*
3	VV005742A	32	28	—	MICH	RAD	XT3	E	SCK	H

Tyre - Rim On									
POS	New or Used	Serial No.	Tread In	Tread Out	Rim No.	Make	Type	Spec	Pressure
3	USED	EVU109379A	45	40	—	MICH	RAD	XT3	

*Action Code		**Removal Reason Code				
A	Scrap	TCUT	Tread Rock cut & Penetration		CSPE	Rock cut Separation
B	Repair	IRRW	Irregular wear, spot wear, rapid wear		PES	Ply turn up Separation
C	Further Inspection	CBU	Ply cord/casing break up		BDCK	Bead gum chaffer cracking
D	Return to mine site	SCUT	Sidewall/shoulder rock & penetration		CS	Ply cord separation
E	Transfer to another site	BEAD	Bead burst, chaffer end separation, rim friction		ILS	Inner liner split or blister
F	Transfer from Supplier	FO	Foreign Object		LOGP	Radial run out
G	Sold	ACCD	Fire, Chemical, rock ejector, loader bucket		LT	Low tread
H	Send for recap	SB	Shock burst, no evidence of rock cut		CB	Rock cut Burst
***Service Code		SCK	Buttress crack, radial crack at shoulder area		SCHD	Schedule Change
A	Tyre rotation	SWC	Sidewall crack		TSEP	Tread Separation
B	Vehicle Maintenance	RO	Run out		RF	Run flat
C	Due to rim problem	VIB	Pattern pitch vibration		SIDE	Sidewall separation
D	Due to tyre problem	BDFT	Improper fitment		HSEP	Heat separation
E	Due to air leak	NA	Not applicable		WO	Worn Out
F	Tyre fitment	WO	Worn Out		MATC	Matching
G	Other reason					

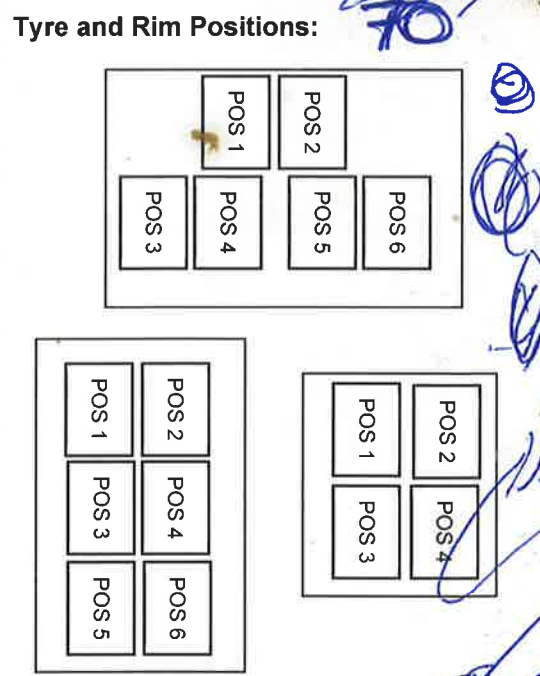



Plant ID:	5009	Site:	Douglas	Tyre and Rim Change	
Tyre Size:	22.25 x 29	Hours:	16.17	Tyre Fitter:	Mr Alexander
				Kilometres:	
				Model:	627
				Date:	7.12.22

POS	Serial No.	Tread In	Tread Out	Rim No.	Make	Type	Spec	Service Code***	Removal Reason Code**	Action Code*
1	HKJSDC697	25	20		Yokohama	Y67	Nylon	F	10	D
2	HKJSOC695	26	29		Yokohama	Y67	Nylon	E	TCUT	A

POS	New or Used	Serial No.	Tread In	Tread Out	Rim No.	Make	Type	Spec	Pressure
1	New	SZEO04218	55	55		Dauque Stone	U steel	Normal	70
2	New	SZE004044	55	55		Dauque Stone	U steel	Normal	70

*Action Code		**Removal Reason Code	
A	Scrap	TCUT	Tread Rock cut & Penetration
B	Repair	IRRW	Irregular wear, spot wear, rapid wear
C	Further Inspection	CBU	Ply cord/casing break up
D	Return to mine site	SCUT	Sidewall/shoulder rock & penetration
E	Transfer to another site	BEAD	Bead burst, chaffer end separation, rim friction
F	Transfer from Supplier	FO	Foreign Object
G	Sold	ACCD	Fire, Chemical, rock ejector, loader bucket
H	Send for recap	SB	Shock burst, no evidence of rock cut
***Service Code		SCK	Buttress crack, radial crack at shoulder area
A	Tyre rotation	SWC	Sidewall crack
B	Vehicle Maintenance	RO	Run out
C	Due to rim problem	VIB	Pattern pitch vibration
D	Due to tyre problem	BDFI	Improper fitment
E	Due to air leak	NA	Not applicable
F	Tyre fitment	WO	Worn Out
G	Other reason		

Tyre and Rim Positions:

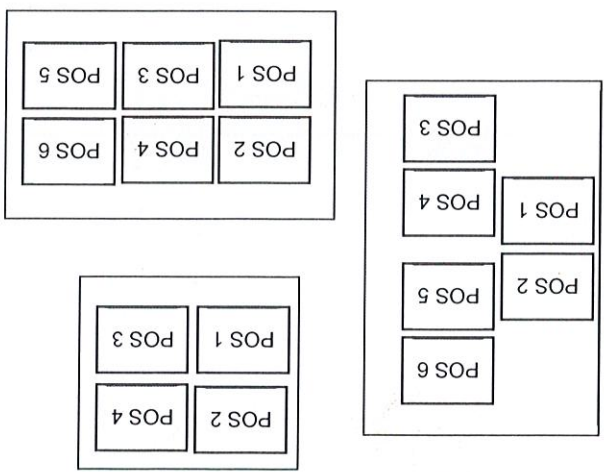

Note: The electronic copy of this document is controlled. To ensure that other copies of this document are current, check the revision number and date against the compliance management database, Qudos

Prepared By: David McNicol Date: 03/02/2020 Approved By: John Stokes Date: 03/02/2020

Rev. No: 2 Date Implemented: 03/02/2020

Tyre and Rim Change

Plant ID:	3009	Site:	Kulu	Tyre Fitter:	REECE YETMAN	Model:	627 G
Tyre Size:	33.25 R 29	Hours:	15339	Kilometres:	-	Date:	10/08/21

Tyre - Rim Off

POS	Serial No.	Tread In	Tread Out	Rim No.	Make	Type	Spec	Service Code***	Removal Reason Code**	Action Code*
4	VVVO1049A	25	25	-	Michelin	XTS	E3	E	CBU	A.

Tyre - Rim On

POS	New or Used	Serial No.	Tread In	Tread Out	Rim No.	Make	Type	Spec	Pressure
4	USED	UVFO0841A	25	25	-	Michelin	XTS	E3	70 PSI

*Action Code		**Removal Reason Code				
A	Scrap	TCUT	Tread Rock cut & Penetration		CSPE	Rock cut Separation
B	Repair	IRRW	Irregular wear, spot wear, rapid wear		PES	Ply turn up Separation
C	Further Inspection	CBU	Ply cord/casing break up		BDCK	Bead gum chaffer cracking
D	Return to mine site	SCUT	Sidewall/shoulder rock & penetration		CS	Ply cord separation
E	Transfer to another site	BEAD	Bead burst, chaffer end separation, rim friction		ILS	Inner liner split or blister
F	Transfer from Supplier	FO	Foreign Object		LOPG	Radial run out
G	Sold	ACCD	Fire, Chemical, rock ejector, loader bucket		LT	Low tread
H	Send for recap	SB	Shock burst, no evidence of rock cut		CB	Rock cut Burst
***Service Code		SCK	Buttress crack, radial crack at shoulder area		SCHD	Schedule Change
A	Tyre rotation	SWC	Sidewall crack		TSEP	Tread Separation
B	Vehicle Maintenance	RO	Run out		RF	Run flat
C	Due to rim problem	VIB	Pattern pitch vibration		SIDE	Sidewall separation
D	Due to tyre problem	BDFT	Improper fitment		HSEP	Heat separation
E	Due to air leak	NA	Not applicable		WO	Worn Out
F	Tyre fitment	WO	Worn Out		MATC	Matching
G	Other reason					

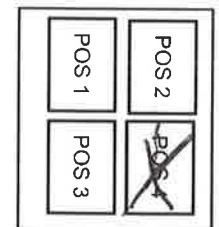
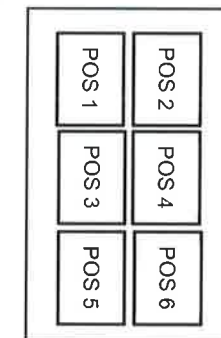
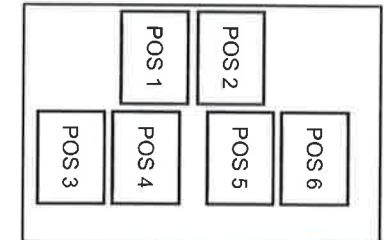
Tyre and Rim Positions:

Note: The electronic copy of this document is controlled. To ensure that other copies of this document are current, check the revision number and date against the compliance management database, Qudos

Prepared By: David McNicol

Date: 03/02/2020

Approved By: John Stokes

Date: 03/02/2020

Rev. No: 2

Date Implemented: 03/02/2020

Tyre and Rim Change

Plant ID:	5009	Site:	Kulwin	Tyre Fitter:	Scott Simpson	Model:	627G
Tyre Size:	33.25 R 29	Hours:	15583	Kilometres:	—	Date:	15/10/21

Tyre – Rim Off

POS	Serial No.	Tread In	Tread Out	Rim No.	Make	Type	Spec	Service Code***	Removal Reason Code**	Action Code*
1	543004811	20 MM	20 MM		Bridgestone	VMT	E-3	B	RO	D
2	543004816	20 MM	20 MM	—	Bridgestone	VMT	E-3	B	RO	D

Tyre – Rim On

POS	New or Used	Serial No.	Tread In	Tread Out	Rim No.	Make	Type	Spec	Pressure
1	NEW	HK3SDC693	45 MM	45 MM	—	Yokohama	Y-67	F-3 32PR	70 PSI
2	NEW	HK3SDC695	45 MM	45 MM	—	Yokohama	Y-67	F-3 32PR	70 PSI

*Action Code		**Removal Reason Code				
A	Scrap	TCUT	Tread Rock cut & Penetration		CSPE	Rock cut Separation
B	Repair	IRRW	Irregular wear, spot wear, rapid wear		PES	Ply turn up Separation
C	Further Inspection	CBU	Ply cord/casing break up		BDCK	Bead gum chaffer cracking
D	Return to mine site	SCUT	Sidewall/shoulder rock & penetration		CS	Ply cord separation
E	Transfer to another site	BEAD	Bead burst, chaffer end separation, rim friction		ILS	Inner liner split or blister
F	Transfer from Supplier	FO	Foreign Object		LOPG	Radial run out
G	Sold	ACCD	Fire, Chemical, rock ejector, loader bucket		LT	Low tread
H	Send for recap	SB	Shock burst, no evidence of rock cut		CB	Rock cut Burst
***Service Code		SCK	Buttress crack, radial crack at shoulder area		SCHD	Schedule Change
A	Tyre rotation	SWC	Sidewall crack		TSEP	Tread Separation
B	Vehicle Maintenance	RO	Run out		RF	Run flat
C	Due to rim problem	VIB	Pattern pitch vibration		SIDE	Sidewall separation
D	Due to tyre problem	BDFT	Improper fitment		HSEP	Heat separation
E	Due to air leak	NA	Not applicable		WO	Worn Out
F	Tyre fitment	WO	Worn Out		MATC	Matching
G	Other reason					

Tyre and Rim Positions:

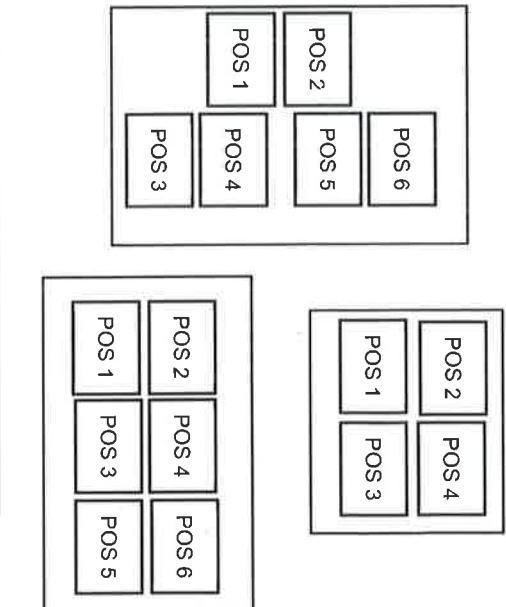

Note: The electronic copy of this document is controlled. To ensure that other copies of this document are current, check the revision number and date against the compliance management database, Qudos

Prepared By:	David McNicol	Date:	03/02/2020	Approved By:	John Stokes	Date:	03/02/2020
Rev. No:	2	Date Implemented:	03/02/2020				

Tyre and Rim Change

Plant ID:	SC09	Site:	WRA	Tyre Fitter:	M. Mentem	Model:	6276
Tyre Size:	33	Hours:	13259	Kilometres:	N/A	Date:	18.3.20

Tyre - Rim Off

POS	Serial No.	Tread In	Tread Out	Rim No.	Make	Type	Spec	Action Code*	Removal Reason Code**	Service Code***
Pos 4	SSK003001	30	31	N/A	B/STONE	V-STEEL RADIAL	RADIAL	A	SB	D

Tyre - Rim On

POS	New or Used	Serial No.	Tread In	Tread Out	Rim No.	Make	Type	Spec	Pressure
4	used	VVV001009A	36	20	N/A	Mitch	Radial	RADIAL	76 psi

*Action Type		**Removal Reason Code				
A	Scrap	TCUT	Tread Rock cut & Penetration		CSPE	Rock cut Separation
B	Repair	IRRW	Irregular wear, spot wear, rapid wear		PES	Ply turn up Separation
C	Further Inspection	CBU	Ply cord/casing break up		BDCK	Bead gum chaffer cracking
D	Return to mine site	SCUT	Sidewall/shoulder rock & penetration		CS	Ply cord separation
E	Transfer to another site	BEAD	Bead burst, chaffer end separation, rim friction		ILS	Inner liner split or blister
F	Transfer from Supplier	FO	Foreign Object		LOPG	Radial run out
G	Sold	ACCD	Fire, Chemical, rock ejector, loader bucket		LT	Low tread
H	Send for recap	SB	Shock burst, no evidence of rock cut		CB	Rock cut Burst
***Service Code		SCK	Buttress crack, radial crack at shoulder area		SCHD	Schedule Change
A	Tyre rotation	SWC	Sidewall crack		TSEP	Tread Separation
B	Vehicle Maintenance	RO	Run out		RF	Run flat
C	Due to rim problem	VIB	Pattern pitch vibration		SIDE	Sidewall separation
D	Due to tyre problem	BDFT	Improper fitment		HSEP	Heat separation
E	Due to air leak	NA	Not applicable		WO	Worn Out
F	Tyre fitment	WO	Worn Out		MATC	Matching
G	Other reason					

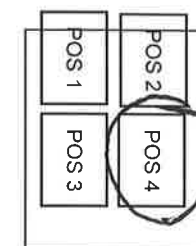
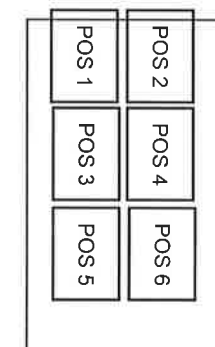
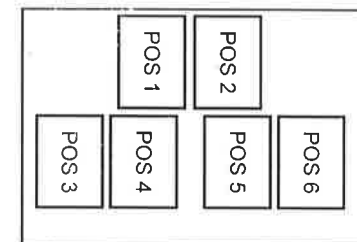
Tyre and Rim Positions:

Note: The electronic copy of this document is controlled. To ensure that other copies of this document are current, check the revision number and date against the compliance management database, Qudos

Prepared By: Julia Crook

Date: 26/04/2016

Approved By: John Stokes

Date: 26/04/2016

Rev. No: 1

Date Implemented: 26/04/2016



Tyre and Rim Change

Plant ID:	3009	Site:	WRP	Tyre Fitter:	John L	Model:	CAT 627G
Tyre Size:	33.25 R29	Hours:	13270	Kilometres:	—	Date:	24/03/20

Tyre – Rim Off

POS	Serial No.	Tread In	Tread Out	Rim No.	Make	Type	Spec	Action Code*	Removal Reason Code**	Service Code***
3	55K003002	10	10	—	Bridgestone	VLT	E3	A	SWC	E

Tyre – Rim On

POS	New or Used	Serial No.	Tread In	Tread Out	Rim No.	Make	Type	Spec	Pressure
3	USED	VV005742A	30	30	—	Michelin	XTS	E3	76 Psi

*Action Type

A	Scrap
B	Repair
C	Further Inspection
D	Return to mine site
E	Transfer to another site
F	Transfer from Supplier
G	Sold
H	Send for recap
***Service Code	
A	Tyre rotation
B	Vehicle Maintenance
C	Due to rim problem
D	Due to tyre problem
E	Due to air leak
F	Tyre fitment
G	Other reason

**Removal Reason Code

TCUT	Tread Rock cut & Penetration	CSPE	Rock cut Separation
IRRW	Irregular wear, spot wear, rapid wear	PES	Ply turn up Separation
CBU	Ply cord/casing break up	BDCK	Bead gum chaffer cracking
SCUT	Sidewall/shoulder rock & penetration	CS	Ply cord separation
BEAD	Bead burst, chaffer end separation, rim friction	ILS	Inner liner split or blister
FO	Foreign Object	LOPG	Radial run out
ACCD	Fire, Chemical, rock ejector, loader bucket	LT	Low tread
SB	Shock burst, no evidence of rock cut	CB	Rock cut Burst
SCK	Buttress crack, radial crack at shoulder area	SCHD	Schedule Change
SWC	Sidewall crack	TSEP	Tread Separation
RO	Run out	RF	Run flat
VIB	Pattern pitch vibration	SIDE	Sidewall separation
BDFT	Improper fitment	HSEP	Heat separation
NA	Not applicable	WO	Worn Out
WO	Worn Out	MATC	Matching

Tyre and Rim Positions:

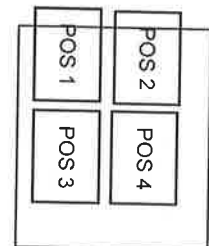
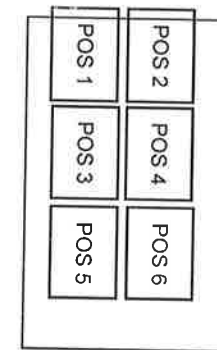
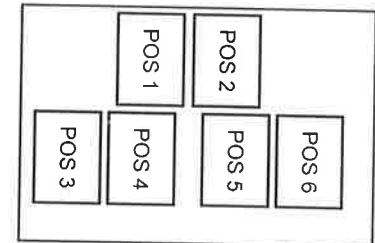

Note: The electronic copy of this document is controlled. To ensure that other copies of this document are current, check the revision number and date against the compliance management database, Qudos

Prepared By: Julia Crook

Date: 26/04/2016

Approved By: John Stokes

Date: 26/04/2016

Rev. No: 1

Date Implemented: 26/04/2016



GARAWAY GROUP

Integrated Management System

Quality Form

Document No. MAF0041

Tyre and Rim Change

Page 1 of 1

Plant ID:	Sc-09	Site:	Dossins Site	Tyre Fitter:	Joel + Dion	Model:	6276
Tyre Size:	33-25R29	Hours:	21, 434 HRS	Kilometres:		Date:	23/11/23

Tyre and Rim Change

POS	Serial No.	Tread		Rim No.	Make	Type	Spec	Service Code****	Removal Reason Code**	Action Code*
		In	Out							
4	57500 2621	26	27		BRIDGESTONE	L-Traction	V-STEEL		SNL	A.
Tyre - Rim On										
POS	New or Used	Serial No.	Tread In	Tread Out	Rim No.	Make	Type	Spec	Pressure	
4	USED-RO	82500108	45	45		BRIDGESTONE	L-Traction	V-STEEL	75 PSI	

***Action Code**

A	Scrap	TCUT	Tread Rock cut & Penetration
B	Repair	IRRW	Irregular wear, spot wear, rapid wear
C	Further Inspection	GBU	Ply cordcasing break up
D	Return to mine site	SCUT	Sidewalls/shoulder rock & penetration
E	Transfer to another site	BEAD	Bead burst, chaffer end separation, rim friction
F	Transfer from Supplier	FO	Foreign Object
G	Sold	ACCD	Fire, Chemical, rock ejector, loader bucket
H	Send for recap	SB	Shock burst, no evidence of rock cut
***Service Code			
A	Tyre rotation	SCK	Buttress crack, radial crack at shoulder area
B	Vehicle Maintenance	SWC	Sidewall crack
C	Due to rim problem	RO	Run out
D	Due to tyre problem	VIB	Pattern pitch vibration
E	Due to air leak	BDFT	Improper fitment
F	Tyre fitment	NA	Not applicable
G	Other reason	WO	Worn Out

****Removal Reason Code**

CSPE	Rock cut Separation
PES	Ply turn up Separation
BDCK	Bead gum chaffer cracking
CS	Ply cord separation
ILS	Inner liner split or blister
LOPG	Radial run out
LT	Low tread
CB	Rock cut Burst
SCHD	Schedule Change
TSEP	Tread Separation
RF	Run flat
SIDE	Sidewall separation
HSEP	Heat separation
WO	Worn Out
MATC	Matching

Tyre and Rim Positions:

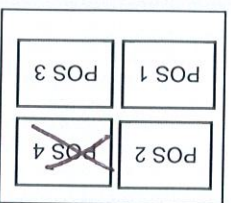
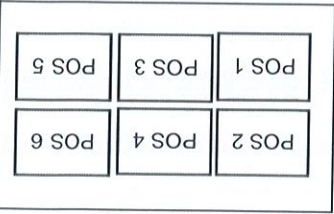
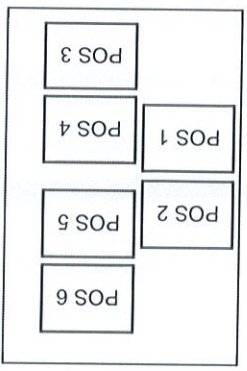

Note: The electronic copy of this document is controlled. To ensure that other copies of this document are current, check the revision number and date against the compliance management database. Qudos

Prepared By: David McNicol Date: 03/02/2020 Approved By: John Stokes Date: 03/02/2020

Rev. No: 2 Date Implemented: 03/02/2020



Tyre and Rim Change

Plant ID: SC09 Site: Dular Tyre Fitter: Tea/10102 Model: 6276-

Tyre Size: 33-25R229 Hours: 16728 hrs Kilometres: Date: 22/11/23.

POS	Serial No.	Tread In	Tread Out	Rim No.		Make	Type	Spec	Service Code***	Removal Reason Code**	Action Code*
				In	Out						
1	S2E004044	44	43			Bridgestone	V-Steel	2A	A	RD	D
2	S2E00428	40	41			Bridgestone	V-Steel	2A	A	RD	D.

POS	New or Used	Serial No.	Tread In	Tread Out	Rim No.		Make	Type	Spec	Pressure
					In	Out				
1	NEW	S2L004084	55	55			Bridgestone	V-Steel	2A	90.
2	NEW	STR002653	55	55			Bridgestone	V-Steel	2A	90

*Action Code		**Removal Reason Code	
A	Scrap	TCUT	Tread Rock cut & Penetration
B	Repair	IRRW	Irregular wear, spot wear, rapid wear
C	Further Inspection	CBU	Ply cord/casing break up
D	Return to mine site	SCUT	Sidewall/shoulder rock & penetration
E	Transfer to another site	BEAD	Bead burst, chaffer end separation, rim friction
F	Transfer from Supplier	FO	Foreign Object
G	Sold	ACCD	Fire, Chemical, rock ejector, loader bucket
H	Send for recap	SB	Shock burst, no evidence of rock cut
***Service Code			
A	Tyre rotation	SCK	Buttress crack, radial crack at shoulder area
B	Vehicle Maintenance	SWC	Sidewall crack
C	Due to rim problem	RO	Run out
D	Due to tyre problem	VIB	Pattern pitch vibration
E	Due to air leak	BDFT	Improper fitment
F	Tyre fitment	NA	Not applicable
G	Other reason	WO	Worn Out

Tyre and Rim Positions:

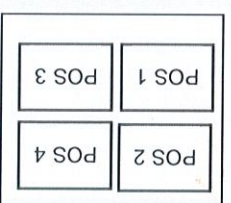
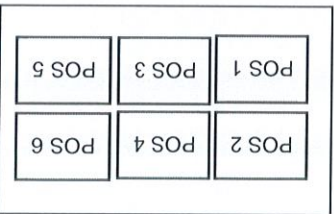
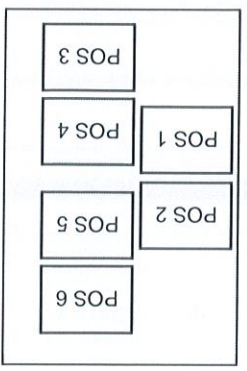

Note: The electronic copy of this document is controlled. To ensure that other copies of this document are current, check the revision number and date against the compliance management database, Qudos

Prepared By: David McNicol Date: 03/02/2020 Approved By: John Stokes Date: 03/02/2020

Rev. No: 2 Date Implemented: 03/02/2020

Tyre and Rim Change

Plant ID: SC09 Site: DOUGLAS Tyre Fitter: Peter Dixon Model: 6276
 Tyre Size: 33.25R229 Hours: 16728 HRS Kilometres: Tyre and Rim Change Date: 23.11.23

POS	Serial No.	Tread In	Tread Out	Rim No.		Make	Type	Spec	Service Code***	Removal Reason Code**	Action Code*
				In	Out						
3	FV10178D1A	35	37			MICHUUN	XTS		A	TSEP	A
4	WF1008D1A	33	31			MICHUUN	XTS		A	CBU	A
Tyre - Rim On											
POS	New or Used	Serial No.	Tread In	Tread Out	Rim No.	Make	Type	Spec	Pressure		
3	USED	S2E004044	44	43		BALSTONE	VSTEEL	2A	75		
4	USED	S2E004218	40	41		BALSTONE	VSTEEL	2A	75		

*Action Code		**Removal Reason Code	
A	Scrap	TCUT	Tread Rock cut & Penetration
B	Repair	IRRW	Irregular wear, spot wear, rapid wear
C	Further Inspection	CBU	Ply cord/casing break up
D	Return to mine site	SCUT	Sidewall/shoulder rock & penetration
E	Transfer to another site	BEAD	Bead burst, chaffer end separation, rim friction
F	Transfer from Supplier	FO	Foreign Object
G	Sold	ACCD	Fire, Chemical, rock ejector, loader bucket
H	Send for recap	SB	Shock burst, no evidence of rock cut
***Service Code			
A	Tyre rotation	SCK	Buttress crack, radial crack at shoulder area
B	Vehicle Maintenance	SWC	Sidewall crack
C	Due to rim problem	RO	Run out
D	Due to tyre problem	VIB	Pattern pitch vibration
E	Due to air leak	BDFT	Improper fitment
F	Tyre fitment	NA	Not applicable
G	Other reason	WO	Worn Out

Tyre and Rim Positions:

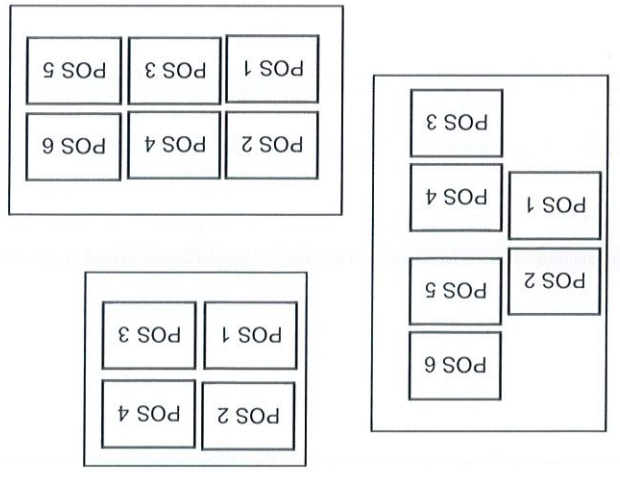

Tyre and Rim Change							
Plant ID:	SC09	Site:	Kulwin	Tyre Fitter:	G. Ellis	Model:	627G
Tyre Size:	33.25R29	Hours:		Kilometres:		Date:	

Tyre - Rim Off										
POS	Serial No.	Tread In	Tread Out	Rim No.	Make	Type	Spec	Service Code***	Removal Reason Code**	Action Code*
3	VVVO057U2A				MICH	RAD		A	MATC	R10
3	EVU1093T9A				MICH	RAD-		A	MATC	R10

Tyre - Rim On										
POS	New or Used	Serial No.	Tread In	Tread Out	Rim No.	Make	Type	Spec	Pressure	

*Action Code		**Removal Reason Code				
A	Scrap	TCUT	Tread Rock cut & Penetration		CSPE	Rock cut Separation
B	Repair	IRRW	Irregular wear, spot wear, rapid wear		PES	Ply turn up Separation
C	Further Inspection	CBU	Ply cord/casing break up		BDCK	Bead gum chaffer cracking
D	Return to mine site	SCUT	Sidewall/shoulder rock & penetration		CS	Ply cord separation
E	Transfer to another site	BEAD	Bead burst, chaffer end separation, rim friction		ILS	Inner liner split or blister
F	Transfer from Supplier	FO	Foreign Object		LOPG	Radial run out
G	Sold	ACCD	Fire, Chemical, rock ejector, loader bucket		LT	Low tread
H	Send for recap	SB	Shock burst, no evidence of rock cut		CB	Rock cut Burst
***Service Code		SCK	Buttress crack, radial crack at shoulder area		SCHD	Schedule Change
A	Tyre rotation	SWC	Sidewall crack		TSEP	Tread Separation
B	Vehicle Maintenance	RO	Run out		RF	Run flat
C	Due to rim problem	VIB	Pattern pitch vibration		SIDE	Sidewall separation
D	Due to tyre problem	BDFT	Improper fitment		HSEP	Heat separation
E	Due to air leak	NA	Not applicable		WO	Worn Out
F	Tyre fitment	WO	Worn Out		MATC	Matching
G	Other reason					

Tyre and Rim Positions:

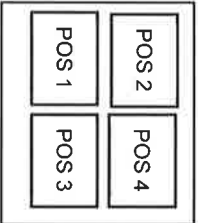
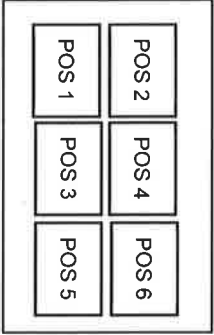
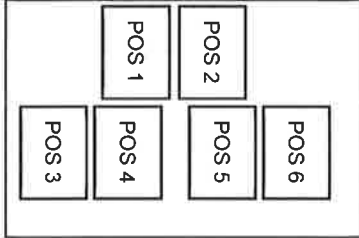



William Adams Pty. Ltd A.B.N. 72 009 569 493 A.C.N. 009 569 493

HEAD OFFICE
17 - 55 Nantilla Road,
Clayton Vic 3168
Tel: (03) 9566 0666

P.O. Box 164,
Clayton Vic 3168
Fax: (03) 9561 6273

VICTORIAN BRANCHES
Bendigo: (03) 5434 2100
Dandenong: (03) 9767 3666
Geelong: (03) 5223 5223
Horsham: (03) 5362 4100
Laverton: (03) 9931 9666

Mildura: (03) 5018 6100
Portland: (03) 5521 5110
Swan Hill: (03) 5036 3900
Traralgon: (03) 5175 6200
Wodonga: (02) 6051 5800

TASMANIAN BRANCHES
Hobart: (03) 6249 0566
Launceston: (03) 6325 0900
Burnie: (03) 6433 8888

SOLD TO:

SHIP TO:

**GARRAWAY EARTHMOVING PTY LTD TRADING AS
GARRAWAY GROUP
PO BOX 3378
MILDURA VIC 3502**

INVOICE No.	INVOICE DATE	CUSTOMER No.	CUSTOMER ORDER No.	STORE	DIV	SALESPERSON	T.C.	PAGE
SR140010344	25-06-20	306150	SC09	14	G	AMF	2	1
DOCUMENT No.	DOCUMENT DATE	PC	LC	MC	SHIP VIA			A.B.N.
EW11904	12-06-20	10	1C	10				54 098 851 631
MAKE	MODEL	SERIAL NUMBER		EQUIPMENT NUMBER	METER READING		MACH. ID No.	
AA	627G	0DBZ00839		SC09R	13613.0			
QUANTITY	ITEM	NR	DESCRIPTION		UNIT PRICE	EXTENSION		

REMOVE & INSTALL ENGINE
REAR

PERFORMED ENGINE REMOVE AND INSTALLATION IN
CONJUNCTION WITH CATERPILLAR CERTIFIED MACHINE
COMPONENT REBUILD - ENGINE PACKAGE
- REPLACED AIR FILTERS AND AIR RESTRICTION GAUGE
- REPLACED ENGINE TO RADIATOR HOSES/CLAMPS
- REPLACED CHARGE AIR HOSES/CLAMPS (TURBO)
- INSPECTED AND FLUSHED RADIATOR ASSEMBLY
- REPLACED COOLANT
- REPLACED ENGINE MOUNTS

ADDITIONAL CUSTOMER INSTALLATION ITEMS
- INSTALLED NEW ELECTRICAL WIRING HARNESS
- INSTALLED ENGINE DRIVE BELTS AND TENSIONERS
- INSTALLED FAN SPIDER ASSEMBLY

COMPLETED MACHINE COMMISSIONING AND ENGINE
PERFORMANCE TESTING, ALL SERVICEABLE.

5% PARTS DISCOUNT APPLIED UPFRONT AND EXCLUDED
FROM REBATE CALCULATION

1	0L-1558	BOLT	S	3.26	3.26
2	2S-4071	SEAL-O-RING	S	15.89	31.78
1	4D-0306	GASKET	S	4.36	4.36
1	4D-0307	CAP	S	98.57	98.57
4	4D-1577	SEAL O RING	S	12.32	49.28
10	4P-7581	CLIP	S	5.37	53.70
10	4P-8134	CLIP	S	5.60	56.00



Please consider recycling this invoice to support our commitment to sustainability. Switch to digital invoicing for a greener option.

E. & O.E.

ITEMS ORDERED NOT SHOWN ARE BACK ORDERED

+ NOT RETURNABLE

TERMS :
EQUIPMENT/RENTAL SALES-CASH EX WORKS
PARTS/SERVICE SALES - STRICTLY NETT 30 DAYS

BANKING DETAILS : ANZ BANK MELBOURNE
BSB : 013 128
ACCOUNT NO : 837 249 625
REFERENCE : 306150
EMAIL YOUR REMITTANCE ADVICE TO :
CreditRegional@wadams.com.au

PAY THIS AMOUNT
Incl GST

CONT ' D

AMOUNT CREDITED
Incl GST



William Adams Pty. Ltd A.B.N. 72 009 569 493 A.C.N. 009 569 493

HEAD OFFICE
17 - 55 Nantilla Road,
Clayton Vic 3168
Tel: (03) 9566 0666

P.O. Box 164,
Clayton Vic 3168
Fax: (03) 9561 6273

VICTORIAN BRANCHES
Bendigo: (03) 5434 2100
Dandenong: (03) 9767 3666
Geelong: (03) 5223 5223
Horsham: (03) 5362 4100
Laverton: (03) 9931 9666

Mildura: (03) 5018 6100
Portland: (03) 5521 5110
Swan Hill: (03) 5036 3900
Traralgon: (03) 5175 6200
Wodonga: (02) 6051 5800

TASMANIAN BRANCHES
Hobart: (03) 6249 0566
Launceston: (03) 6325 0900
Burnie: (03) 6433 8888

SOLD TO:

SHIP TO:

**GARRAWAY EARTHMOVING PTY LTD TRADING AS
GARRAWAY GROUP
PO BOX 3378
MILDURA VIC 3502**

INVOICE No.	INVOICE DATE	CUSTOMER No.	CUSTOMER ORDER No.	STORE	DIV	SALESPERSON	T.C.	PAGE
SR140010344	25-06-20	306150	SC09	14	G	AMF	2	2
DOCUMENT No.	DOCUMENT DATE	PC	LC	MC	SHIP VIA			A.B.N.
EW11904	12-06-20	10	1C	10				54 098 851 631
MAKE	MODEL	SERIAL NUMBER		EQUIPMENT NUMBER	METER READING		MACH. ID No.	
AA	627G	0DBZ00839		SC09R	13613.0			
QUANTITY	ITEM	NR	DESCRIPTION		UNIT PRICE	EXTENSION		
2	4W-1203		CUP	S	19.69	39.38		
2	4W-1204		CONE	S	30.58	61.16		
1	4W-8118		CLAMP	S	87.32	87.32		
2	5H-7844		GASKET	S	6.42	12.84		
2	5M-7329		SEAL O RING	S	17.10	34.20		
60	5P-2817		CM-HOSE STK	S	.73	43.80		
1	5S-9062		SPACER	S	34.99	34.99		
1	5T-9093		GAGE-OIL	S	75.18	75.18		
3	6V-1820		BOLT	S	.76	2.28		
2	6V-3822		BOLT	S	.86	1.72		
4	6V-8849		BOLT	S	36.94	147.76		
1	6V-9748		SEAL	S	12.14	12.14		
1	7C-8370		CAP	S	16.21	16.21		
4	7D-7111		SEAL-O-RING	S	35.40	141.60		
3	7X-0320		BOLT	S	4.94	14.82		
22	7X-0346		BOLT	S	3.43	75.46		
2	8M-4987		SEAL O RING	S	5.71	11.42		
2	8M-5010		SEAL O RIN	S	8.29	16.58		
2	8M-8281		SEAL O RING	S	2.44	4.88		
1	8S-9379		HOSE	S	15.18	15.18		
4	8T-4136		BOLT	S	.89	3.56		
4	8T-4195		BOLT	S	1.04	4.16		
4	8T-4994		WASHER	S	1.82	7.28		
1	8T-5092		BOLT	S	6.92	6.92		
8	8T-8925		BOLT	S	11.46	91.68		
2	9M-7539		SEAL O RING	S	10.18	20.36		
3	106-9858		HOSE	S	186.46	559.38		
1	111-7092		HOSE	S	25.34	25.34		
1	134-4040		SPIDER A-FAN	S	1622.69	1622.69		



Please consider recycling this invoice to support our commitment to sustainability. Switch to digital invoicing for a greener option.

E. & O.E.

ITEMS ORDERED NOT SHOWN ARE BACK ORDERED

+ NOT RETURNABLE

TERMS :
EQUIPMENT/RENTAL SALES-CASH EX WORKS
PARTS/SERVICE SALES - STRICTLY NETT 30 DAYS

BANKING DETAILS : ANZ BANK MELBOURNE
BSB : 013 128
ACCOUNT NO : 837 249 625
REFERENCE : 306150
EMAIL YOUR REMITTANCE ADVICE TO :
CreditRegional@wadams.com.au

PAY THIS AMOUNT
Incl GST

CONT ' D

AMOUNT CREDITED
Incl GST



William Adams Pty. Ltd A.B.N. 72 009 569 493 A.C.N. 009 569 493

HEAD OFFICE
17 - 55 Nantilla Road,
Clayton Vic 3168
Tel: (03) 9566 0666

P.O. Box 164,
Clayton Vic 3168
Fax: (03) 9561 6273

VICTORIAN BRANCHES
Bendigo: (03) 5434 2100
Dandenong: (03) 9767 3666
Geelong: (03) 5223 5223
Horsham: (03) 5362 4100
Laverton: (03) 9931 9666

Mildura: (03) 5018 6100
Portland: (03) 5521 5110
Swan Hill: (03) 5036 3900
Traralgon: (03) 5175 6200
Wodonga: (02) 6051 5800

TASMANIAN BRANCHES
Hobart: (03) 6249 0566
Launceston: (03) 6325 0900
Burnie: (03) 6433 8888

SOLD TO:

SHIP TO:

**GARRAWAY EARTHMOVING PTY LTD TRADING AS
GARRAWAY GROUP
PO BOX 3378
MILDURA VIC 3502**

INVOICE No.	INVOICE DATE	CUSTOMER No.	CUSTOMER ORDER No.	STORE	DIV	SALESPERSON	T.C.	PAGE
SR140010344	25-06-20	306150	SC09	14	G	AMF	2	3
DOCUMENT No.	DOCUMENT DATE	PC	LC	MC	SHIP VIA			A.B.N.
EW11904	12-06-20	10	1C	10				54 098 851 631
MAKE	MODEL	SERIAL NUMBER		EQUIPMENT NUMBER	METER READING		MACH. ID No.	
AA	627G	0DBZ00839		SC09R	13613.0			

QUANTITY	ITEM	NR	DESCRIPTION	UNIT PRICE	EXTENSION
1	148-6870		HOSE AS	72.71	72.71
1	159-0225		HOSE AS	90.78	90.78
2	160-8742		BOLT-HEX HEA	1.35	2.70
10	183-7121		BOLT	1.38	13.80
1	200-2258		GASKET	3.39	3.39
2	209-4573		CLAMP-T'BOLT	11.49	22.98
4	209-4578		CLAMP-T'BOLT	11.46	45.84
2	212-6933		CLAMP-T'BOLT	11.22	22.44
1	215-8029		HOSE AS.	284.64	284.64
1	216-0273		SEAL-LIP TYP	72.00	72.00
1	228-6892		HARNESS AS	1197.21	1197.21
1	228-6973		HARNESS AS	1952.89	1952.89
1	279-2589		PULLEY AS.	185.79	185.79
12	299-3398		BOLT HEX	5.31	63.72
1	309-4069		HOSE-HUMP	72.33	72.33
1	321-7076		HOSE AS.	278.61	278.61
1	330-0662		BELT	153.13	153.13
1	330-0663		BELT	93.51	93.51
2	361-1713		TRUNNION-YM	394.75	789.50
150	371-8094		CM HOSE BULK	.45	67.50
50	371-8946		CM HOSE BULK	1.21	60.50
1	375-8345		TENSIONER AS	322.25	322.25
1	381-2509		TENSIONER	372.07	372.07
1	381-2512		PULLEY	323.04	323.04
1	388-7016		CLAMP-BENT B	23.43	23.43
2	396-0664		CAP-BRG-YM	149.81	299.62
4	421-3152		NUT-HEX	1.10	4.40
4	421-3183		BOLT-HEX HEA	4.31	17.24
100	423-1980		IN HOSE-BULK	.36	36.00



Please consider recycling this invoice to support our commitment to sustainability. Switch to digital invoicing for a greener option.

E. & O.E.

ITEMS ORDERED NOT SHOWN ARE BACK ORDERED

+ NOT RETURNABLE

TERMS :
EQUIPMENT/RENTAL SALES-CASH EX WORKS
PARTS/SERVICE SALES - STRICTLY NETT 30 DAYS

BANKING DETAILS : ANZ BANK MELBOURNE
BSB : 013 128
ACCOUNT NO : 837 249 625
REFERENCE : 306150
EMAIL YOUR REMITTANCE ADVICE TO :
CreditRegional@wadams.com.au

PAY THIS AMOUNT
Incl GST

CONT ' D

AMOUNT CREDITED
Incl GST



William Adams Pty. Ltd A.B.N. 72 009 569 493 A.C.N. 009 569 493

HEAD OFFICE
17 - 55 Nantilla Road,
Clayton Vic 3168
Tel: (03) 9566 0666

P.O. Box 164,
Clayton Vic 3168
Fax: (03) 9561 6273

VICTORIAN BRANCHES
Bendigo: (03) 5434 2100
Dandenong: (03) 9767 3666
Geelong: (03) 5223 5223
Horsham: (03) 5362 4100
Laverton: (03) 9931 9666

Mildura: (03) 5018 6100
Portland: (03) 5521 5110
Swan Hill: (03) 5036 3900
Traralgon: (03) 5175 6200
Wodonga: (02) 6051 5800

TASMANIAN BRANCHES
Hobart: (03) 6249 0566
Launceston: (03) 6325 0900
Burnie: (03) 6433 8888

SOLD TO:

SHIP TO:

**GARRAWAY EARTHMOVING PTY LTD TRADING AS
GARRAWAY GROUP
PO BOX 3378
MILDURA VIC 3502**

INVOICE No.	INVOICE DATE	CUSTOMER No.	CUSTOMER ORDER No.	STORE	DIV	SALESPERSON	T.C.	PAGE
SR140010344	25-06-20	306150	SC09	14	G	AMF	2	4
DOCUMENT No.	DOCUMENT DATE	PC	LC	MC	SHIP VIA			A.B.N.
EW11904	12-06-20	10	1C	10				54 098 851 631
MAKE	MODEL	SERIAL NUMBER		EQUIPMENT NUMBER	METER READING		MACH. ID No.	
AA	627G	0DBZ00839		SC09R	13613.0			
QUANTITY	ITEM	NR	DESCRIPTION		UNIT PRICE	EXTENSION		
1	431-2155		YOKE-YM S		450.76	450.76		
			TOTAL PARTS		SEG. 10	10882.02 *		
			LESS		5%-PARTS	544.08 - *		
					F/R LBR	3840.00 *		
					F/R MSC	605.29 *		
			SEGMENT 10 TOTAL			14783.23 T		

REMAN ENGINE								
SUPPLY REMAN ENGINE ASSEMBLY 20R-1785								

5% PARTS DISCOUNT APPLIED UPFRONT AND EXCLUDED FROM REBATE CALCULATION								
1	20R-1785		ENG AR COMP N		43666.77	43666.77		
1			CORE DEPOSIT N		16981.53	16981.53		
1-			CORE RETURN N		16981.53	16981.53-		
			TOTAL PARTS		SEG. 15	43666.77 *		
			LESS		5%-PARTS	2183.34 - *		
			SEGMENT 15 TOTAL			41483.43 T		

WARRANTY BAD CODE ENGINE								



Please consider recycling this invoice to support our commitment to sustainability. Switch to digital invoicing for a greener option.

E. & O.E.

ITEMS ORDERED NOT SHOWN ARE BACK ORDERED

+ NOT RETURNABLE

TERMS :
EQUIPMENT/RENTAL SALES-CASH EX WORKS
PARTS/SERVICE SALES - STRICTLY NETT 30 DAYS

BANKING DETAILS : ANZ BANK MELBOURNE
BSB : 013 128
ACCOUNT NO : 837 249 625
REFERENCE : 306150
EMAIL YOUR REMITTANCE ADVICE TO :
CreditRegional@wadams.com.au

PAY THIS AMOUNT
Incl GST

CONT ' D

AMOUNT CREDITED
Incl GST



William Adams Pty. Ltd A.B.N. 72 009 569 493 A.C.N. 009 569 493

HEAD OFFICE
17 - 55 Nantilla Road,
Clayton Vic 3168
Tel: (03) 9566 0666

P.O. Box 164,
Clayton Vic 3168
Fax: (03) 9561 6273

VICTORIAN BRANCHES
Bendigo: (03) 5434 2100
Dandenong: (03) 9767 3666
Geelong: (03) 5223 5223
Horsham: (03) 5362 4100
Laverton: (03) 9931 9666

Mildura: (03) 5018 6100
Portland: (03) 5521 5110
Swan Hill: (03) 5036 3900
Traralgon: (03) 5175 6200
Wodonga: (02) 6051 5800

TASMANIAN BRANCHES
Hobart: (03) 6249 0566
Launceston: (03) 6325 0900
Burnie: (03) 6433 8888

SOLD TO:

SHIP TO:

**GARRAWAY EARTHMOVING PTY LTD TRADING AS
GARRAWAY GROUP
PO BOX 3378
MILDURA VIC 3502**

INVOICE No.	INVOICE DATE	CUSTOMER No.	CUSTOMER ORDER No.	STORE	DIV	SALESPERSON	T.C.	PAGE
SR140010344	25-06-20	306150	SC09	14	G	AMF	2	5
DOCUMENT No.	DOCUMENT DATE	PC	LC	MC	SHIP VIA			A.B.N.
EW11904	12-06-20	10	1C	10				54 098 851 631
MAKE	MODEL	SERIAL NUMBER		EQUIPMENT NUMBER	METER READING		MACH. ID No.	
AA	627G	0DBZ00839		SC09R	13613.0			
QUANTITY	ITEM	NR	DESCRIPTION		UNIT PRICE	EXTENSION		

SUPPLY EQUIPMENT PROTECTION PLAN (EPP) THREE YEARS
5000HRS WARRANTY COVERAGE FOR CMCR-ENGINE
VALUED AT \$1897.50

SEGMENT 20 TOTAL .00 T

TRAVEL TO/FROM CUSTOMER SITE

TRAVEL TO/FROM CUSTOMER SITE, LOCATED AT WRP
MINE SITE.

F/R MSC 660.00 *

SEGMENT 99 TOTAL 660.00 T

ENVIR/CONSUM CHG 192.00 T

Subtotal before taxes 57118.66

G.S.T. 5711.87 T

OUR PREFERRED METHOD OF PAYMENT IS BY EFT
OUR BANKING DETAILS ARE:
ANZ BANK MELBOURNE
BSB: 013 128



Please consider recycling this invoice to support our commitment to sustainability. Switch to digital invoicing for a greener option.

E. & O.E.

ITEMS ORDERED NOT SHOWN ARE BACK ORDERED

+ NOT RETURNABLE

TERMS :
EQUIPMENT/RENTAL SALES-CASH EX WORKS
PARTS/SERVICE SALES - STRICTLY NETT 30 DAYS

BANKING DETAILS : ANZ BANK MELBOURNE
BSB : 013 128
ACCOUNT NO : 837 249 625
REFERENCE : 306150
EMAIL YOUR REMITTANCE ADVICE TO :
CreditRegional@wadams.com.au

PAY THIS AMOUNT
Incl GST

CONT 'D

AMOUNT CREDITED
Incl GST

William Adams



TAX INVOICE

William Adams Pty. Ltd A.B.N. 72 009 569 493 A.C.N. 009 569 493

HEAD OFFICE
17 - 55 Nantilla Road,
Clayton Vic 3168
Tel: (03) 9566 0666

P.O. Box 164,
Clayton Vic 3168
Fax: (03) 9561 6273

VICTORIAN BRANCHES
Bendigo: (03) 5434 2100
Dandenong: (03) 9767 3666
Geelong: (03) 5223 5223
Horsham: (03) 5362 4100
Laverton: (03) 9931 9666

Mildura: (03) 5018 6100
Portland: (03) 5521 5110
Swan Hill: (03) 5036 3900
Traralgon: (03) 5175 6200
Wodonga: (02) 6051 5800

TASMANIAN BRANCHES
Hobart: (03) 6249 0566
Launceston: (03) 6325 0900
Burnie: (03) 6433 8888

SOLD TO:

SHIP TO:

**GARRAWAY EARTHMOVING PTY LTD TRADING AS
GARRAWAY GROUP
PO BOX 3378
MILDURA VIC 3502**

INVOICE No.	INVOICE DATE	CUSTOMER No.	CUSTOMER ORDER No.	STORE	DIV	SALESPERSON	T.C.	PAGE
SR140010344	25-06-20	306150	SC09	14	G	AMF	2	6
DOCUMENT No.	DOCUMENT DATE	PC	LC	MC	SHIP VIA			A.B.N.
EW11904	12-06-20	10	1C	10				54 098 851 631
MAKE	MODEL	SERIAL NUMBER		EQUIPMENT NUMBER	METER READING		MACH. ID No.	
AA	627G	0DBZ00839		SC09R	13613.0			
QUANTITY	ITEM	NR	DESCRIPTION			UNIT PRICE	EXTENSION	

ACCOUNT NO: 837 249 625
PLEASE QUOTE YOUR CUSTOMER NO. AS THE REFERENCE AND
EMAIL YOUR REMITTANCE ADVICE TO: CREDIT@WADAMS.COM.AU

THANK YOU FOR CHOOSING WILLIAM ADAMS
HELP US IMPROVE VIA FEEDBACK@WADAMS.COM.AU

BANKING DETAILS: ANZ BANK - MELBOURNE
BSB: 013 128

ACCOUNT NO: 8372 49625
REFERENCE: YOUR CUSTOMER NUMBER

EMAIL YOUR REMITTANCE ADVICE TO: CREDITMILDURA@WADAMS.COM.AU
* * * INVOICE COPY * * *



Please consider recycling this invoice to support our commitment to sustainability. Switch to digital invoicing for a greener option.

E. & O.E.

ITEMS ORDERED NOT SHOWN ARE BACK ORDERED

+ NOT RETURNABLE

TERMS :
EQUIPMENT/RENTAL SALES-CASH EX WORKS
PARTS/SERVICE SALES - STRICTLY NETT 30 DAYS

BANKING DETAILS : ANZ BANK MELBOURNE
BSB : 013 128
ACCOUNT NO : 837 249 625
REFERENCE : 306150
EMAIL YOUR REMITTANCE ADVICE TO :
CreditRegional@wadams.com.au

PAY THIS AMOUNT
Incl GST AUD 62830.53

AMOUNT CREDITED
Incl GST

WA24

William Adams Pty Ltd's Standard Conditions of Quotation and Sale apply to this transaction.
They can be obtained at www.williamadams.com.au/termsandconditions or by calling (03) 9566 0666
Thank You for choosing William Adams. Help us improve via FEEDBACK@WADAMS.COM.AU



**CHARLES HULL
CONTRACTING**

TAX INVOICE

Charles Hull Contracting Co. Pty Ltd

P.O. Box 63

Waroona 6215

Phone: 08 9782 6900

ABN: 20008694406

Customer:

Garraway Group
PO Box 3378
Mildura VIC 3502

Invoice No: 651927

Invoice Date: 16-JUL-24

Account MISC001

Order Reference CAT 627F REAR DIFF

Our Order No 651927

Item Code	Item Description	Ordered	UOM	Item Price (Ex GST)	Line Total (Ex GST)
	2ND HAND CAT 627 APRON 208-2977 REAR DIFFERENTIAL AS IS WHERE IS	1.00		8,000.00	8,000.00

Bank Details:

Acc. Name: Charles Hull Contracting

BSB 086-956

Acc. No.: 508377909

Total Ex 8,000.00

GST 800.00

Total 8,800.00

Remittances emailed to ar@charleshull.com.au

William Adams



TAX INVOICE

William Adams Pty. Ltd A.B.N. 72 009 569 493 A.C.N. 009 569 493

HEAD OFFICE
17 - 55 Nantilla Road,
Clayton Vic 3168
Tel: (03) 9566 0666

P.O. Box 164,
Clayton Vic 3168
Fax: (03) 9561 6273

VICTORIAN BRANCHES
Bendigo: (03) 5434 2100
Dandenong: (03) 9767 3666
Geelong: (03) 5223 5223
Horsham: (03) 5362 4100
Laverton: (03) 9931 9666

Mildura: (03) 5018 6100
Portland: (03) 5521 5110
Swan Hill: (03) 5036 3900
Traralgon: (03) 5175 6200
Wodonga: (02) 6051 5800

TASMANIAN BRANCHES
Hobart: (03) 6249 0566
Launceston: (03) 6325 0900
Burnie: (03) 6433 8888

SOLD TO:

GARRAWAY EARTHMOVING PTY LTD TRADING AS
GARRAWAY GROUP
PO BOX 3378
MILDURA VIC 3502

SHIP TO:

GARRAWAY EARTHMOVING PTY LTD
367 BENETOOK AVENUE
MILDURA VIC 3500

INVOICE No.	INVOICE DATE	CUSTOMER No.	CUSTOMER ORDER No.	STORE	DIV	SALESPERSON	T.C.	PAGE
P2PR0119866	29-03-22	306150	SC09	14	G		2	1
DOCUMENT No.	DOCUMENT DATE	PC	LC	MC	SHIP VIA			A.B.N.
14C108738	29-03-22	10		10				54 098 851 631
MAKE	MODEL	SERIAL NUMBER		EQUIPMENT NUMBER	METER READING		MACH. ID No.	
AA	627G	0DBD00838		SC09				
QUANTITY	ITEM	NR	DESCRIPTION			UNIT PRICE	EXTENSION	

PARTS SALES PERSON: AARON FRY

1	1982806		TC GP	S	15000.00	15000.00	
			TOTAL PARTS			15000.00	T

 Subtotal before taxes 15000.00
 G.S.T. 1500.00 T

* * * INVOICE COPY * * *



Please consider recycling this invoice to support our commitment to sustainability. Switch to digital invoicing for a greener option.

E. & O.E.

ITEMS ORDERED NOT SHOWN ARE BACK ORDERED

+ NOT RETURNABLE

TERMS :
EQUIPMENT/RENTAL SALES-CASH EX WORKS
PARTS/SERVICE SALES - STRICTLY NETT 30 DAYS

BANKING DETAILS : ANZ BANK MELBOURNE
BSB : 013 128
ACCOUNT NO : 837 249 625
REFERENCE : 306150
EMAIL YOUR REMITTANCE ADVICE TO :
CreditRegional@wadams.com.au

PAY THIS AMOUNT
Incl GST AUD 16500.00

AMOUNT CREDITED
Incl GST

WA24

William Adams Pty Ltd's Standard Conditions of Quotation and Sale apply to this transaction.
They can be obtained at www.williamadams.com.au/termsandconditions or by calling (03) 9566 0666
Thank You for choosing William Adams. Help us improve via FEEDBACK@WADAMS.COM.AU

William Adams



TAX INVOICE

William Adams Pty. Ltd A.B.N. 72 009 569 493 A.C.N. 009 569 493

HEAD OFFICE
17 - 55 Nantilla Road,
Clayton Vic 3168
Tel: (03) 9566 0666

P.O. Box 164,
Clayton Vic 3168
Fax: (03) 9561 6273

VICTORIAN BRANCHES
Bendigo: (03) 5434 2100
Dandenong: (03) 9767 3666
Geelong: (03) 5223 5223
Horsham: (03) 5362 4100
Laverton: (03) 9931 9666

Mildura: (03) 5018 6100
Portland: (03) 5521 5110
Swan Hill: (03) 5036 3900
Traralgon: (03) 5175 6200
Wodonga: (02) 6051 5800

TASMANIAN BRANCHES
Hobart: (03) 6249 0566
Launceston: (03) 6325 0900
Burnie: (03) 6433 8888

SOLD TO:

GARRAWAY EARTHMOVING PTY LTD TRADING AS
GARRAWAY GROUP
PO BOX 3378
MILDURA VIC 3502

SHIP TO:

Horsham
81-83 Dimboola Road
Horsham
VIC 3402 AU

INVOICE No.	INVOICE DATE	CUSTOMER No.	CUSTOMER ORDER No.	STORE	DIV	SALESPERSON	T.C.	PAGE
P2PR0155397	23-06-22	306150	SC09	05	G		2	1
DOCUMENT No.	DOCUMENT DATE	PC	LC	MC	SHIP VIA			A.B.N.
05C209193A	22-06-22	10		10	EXPRESS OUTBND			54 098 851 631
MAKE	MODEL	SERIAL NUMBER		EQUIPMENT NUMBER	METER READING		MACH. ID No.	
QUANTITY	ITEM	NR	DESCRIPTION		UNIT PRICE	EXTENSION		

PARTS SALES PERSON: COMMERCE ORDER

1	10R-3667		CORE AS OIL	N	2955.47	2955.47
1	10R-3667		CORE DEPOSIT	N	1207.19	1207.19
			TOTAL PARTS			4162.66 T

Subtotal before taxes 4162.66
G.S.T. 416.27 T

baden.hetherington@garraway.com.au
Douglas mine

* * * INVOICE COPY * * *



Please consider recycling this invoice to support our commitment to sustainability. Switch to digital invoicing for a greener option.

E. & O.E.

ITEMS ORDERED NOT SHOWN ARE BACK ORDERED

+ NOT RETURNABLE

TERMS :
EQUIPMENT/RENTAL SALES-CASH EX WORKS
PARTS/SERVICE SALES - STRICTLY NETT 30 DAYS

BANKING DETAILS : ANZ BANK MELBOURNE
BSB : 013 128
ACCOUNT NO : 837 249 625
REFERENCE : 306150
EMAIL YOUR REMITTANCE ADVICE TO :
CreditRegional@wadams.com.au

PAY THIS AMOUNT
Incl GST AUD 4578.93

AMOUNT CREDITED
Incl GST

WA24

William Adams Pty Ltd's Standard Conditions of Quotation and Sale apply to this transaction. They can be obtained at www.williamadams.com.au/termsandconditions or by calling (03) 9566 0666 Thank You for choosing William Adams. Help us improve via FEEDBACK@WADAMS.COM.AU



William Adams Pty. Ltd A.B.N. 72 009 569 493 A.C.N. 009 569 493

HEAD OFFICE
17 - 55 Nantilla Road,
Clayton Vic 3168
Tel: (03) 9566 0666

P.O. Box 164,
Clayton Vic 3168
Fax: (03) 9561 6273

VICTORIAN BRANCHES
Bendigo: (03) 5434 2100
Dandenong: (03) 9767 3666
Geelong: (03) 5223 5223
Horsham: (03) 5362 4100
Laverton: (03) 9931 9666

Mildura: (03) 5018 6100
Portland: (03) 5521 5110
Swan Hill: (03) 5036 3900
Traralgon: (03) 5175 6200
Wodonga: (02) 6051 5800

TASMANIAN BRANCHES
Hobart: (03) 6249 0566
Launceston: (03) 6325 0900
Burnie: (03) 6433 8888

SOLD TO:

**GARRAWAY EARTHMOVING PTY LTD TRADING AS
GARRAWAY GROUP
PO BOX 3378
MILDURA VIC 3502**

SHIP TO:

**Horsham
81-83 Dimboola Road
Horsham
VIC 3402 AU**

INVOICE No.	INVOICE DATE	CUSTOMER No.	CUSTOMER ORDER No.	STORE	DIV	SALESPERSON	T.C.	PAGE
P2PR0364962	19-12-23	306150	SC09/Dion	05	G		2	1
DOCUMENT No.	DOCUMENT DATE	PC	LC	MC	SHIP VIA			A.B.N.
05C217771A	15-12-23	10		10	EXPRESS OUTBND			54 098 851 631
MAKE	MODEL	SERIAL NUMBER		EQUIPMENT NUMBER	METER READING		MACH. ID No.	
AA	627G	0DBD00838		SC09				
QUANTITY	ITEM	NR	DESCRIPTION		UNIT PRICE	EXTENSION		

PARTS SALES PERSON: COMMERCE ORDER

1	201-6615		SENSOR GP-SPEED	S	261.04	261.04
1	338-1462		SENSOR GP-PO	N	1207.42	1207.42
Replaces Part # (1988761)						
11	1T-0680		SPRING	N	10.90	119.90
8	8E-8300		DISC	N	11.53	92.24
1	1T-1347		BEARING	N	105.51	105.51
1	5S-4442		BEARING	N	63.33	63.33
8	2S-0669		BEARING A	N	23.64	189.12
4	1M-3780		BEARING	N	48.49	193.96
11	1T-0679		ROLLER	N	11.58	127.38
1	5P-6230		BEARING	N	224.86	224.86
1	3K-0526		BEARING	N	95.08	95.08
16	4M-3915		BEARING-CAGED	N	28.21	451.36
2	1T-1078		BEARING-THRUST	N	73.53	147.06
2	6B-6863		DOWEL	N	1.96	3.92
2	106-7799		BEARING	N	142.03	284.06
4	3S-2660		SPACER	N	25.81	103.24
16	8E-8307		DISC	N	14.29	228.64
2	6F-0155		RING	N	17.72	35.44
2	1T-0655		BEARING-THRUST	N	252.94	505.88
2	4H-8380		PIN	N	1.96	3.92
2	147-0045		PIN	N	2.24	4.48
1	204-2460		BEARING-SLEE	N	52.13	52.13
6	5M-5018		BEARING-ROLLER	N	25.57	153.42
2	8P-1958		WASHER THRU	N	75.13	150.26
4	030-0060		CUP	S	66.65	266.60
1	284-3599		CAM-FREEWHEEL	N	2020.08	2020.08



Please consider recycling this invoice to support our commitment to sustainability. Switch to digital invoicing for a greener option.

E. & O.E.

ITEMS ORDERED NOT SHOWN ARE BACK ORDERED

+ NOT RETURNABLE

TERMS :
EQUIPMENT/RENTAL SALES-CASH EX WORKS
PARTS/SERVICE SALES - STRICTLY NETT 30 DAYS

BANKING DETAILS : ANZ BANK MELBOURNE
BSB : 013 128
ACCOUNT NO : 837 249 625
REFERENCE : 306150
EMAIL YOUR REMITTANCE ADVICE TO :
CreditRegional@wadams.com.au

PAY THIS AMOUNT
Incl GST

CONT ' D

AMOUNT CREDITED
Incl GST



William Adams Pty. Ltd A.B.N. 72 009 569 493 A.C.N. 009 569 493

HEAD OFFICE
17 - 55 Nantilla Road,
Clayton Vic 3168
Tel: (03) 9566 0666

P.O. Box 164,
Clayton Vic 3168
Fax: (03) 9561 6273

VICTORIAN BRANCHES
Bendigo: (03) 5434 2100
Dandenong: (03) 9767 3666
Geelong: (03) 5223 5223
Horsham: (03) 5362 4100
Laverton: (03) 9931 9666

Mildura: (03) 5018 6100
Portland: (03) 5521 5110
Swan Hill: (03) 5036 3900
Traralgon: (03) 5175 6200
Wodonga: (02) 6051 5800

TASMANIAN BRANCHES
Hobart: (03) 6249 0566
Launceston: (03) 6325 0900
Burnie: (03) 6433 8888

SOLD TO:

**GARRAWAY EARTHMOVING PTY LTD TRADING AS
GARRAWAY GROUP
PO BOX 3378
MILDURA VIC 3502**

SHIP TO:

**Horsham
81-83 Dimboola Road
Horsham
VIC 3402 AU**

INVOICE No.	INVOICE DATE	CUSTOMER No.	CUSTOMER ORDER No.	STORE	DIV	SALESPERSON	T.C.	PAGE
P2PR0364962	19-12-23	306150	SC09/Dion	05	G		2	2
DOCUMENT No.	DOCUMENT DATE	PC	LC	MC	SHIP VIA			A.B.N.
05C217771A	15-12-23	10		10	EXPRESS OUTBND			54 098 851 631
MAKE	MODEL	SERIAL NUMBER		EQUIPMENT NUMBER	METER READING		MACH. ID No.	
AA	627G	0DBD00838		SC09				
QUANTITY	ITEM	NR	DESCRIPTION		UNIT PRICE	EXTENSION		
6	177-7886		CONE		145.15	870.90		
1	5S-4441		DOWEL		6.46	6.46		
1	1M-4169		RING		30.49	30.49		
3	5M-2054		BEARING A		25.85	77.55		
1	5P-7661		BEARING		17.76	17.76		
1	1T-0647		BEARING-SLEEVE		46.03	46.03		
1	9M-2001		DOWEL		5.69	5.69		
4	6V-5701		BEARING		5.83	23.32		
1	421-3135		PIN-SPRING		4.17	4.17		
1	1T-0762		RACE-THRUST BEARIN		78.36	78.36		
1	1T-0648		*SEAL R METAL		26.19	26.19		
2	5P-9400		BEARING		20.54	41.08		
2	1T-0657		PLATE		88.60	177.20		
1	3D-8823		BEARING		23.13	23.13		
1	1T-0767		BEARING-SLEEVE		47.38	47.38		
3	1T-0686		RACE-BEARING-THRUN		82.10	246.30		
5	6B-1369		RIVET		.43	2.15		
1	6H-7201		RING		14.29	14.29		
1	3S-0109		PLATE		140.79	140.79		
18	8E-8304		DISC		13.00	234.00		
1	3S-1292		BEARING-SLEE		95.60	95.60		
1	1B-3867		BEARING		48.68	48.68		
1	203-2060		RETAINER-BEA		48.15	48.15		
1	8S-3373		RING-SEAL		53.00	53.00		
1	8M-6541		SEAL		29.33	29.33		
1	238-5080		SEAL-O-RING		9.39	9.39		
1	8M-1112		SEAL O RIN		6.00	6.00		
2	3S-1282		RING		55.42	110.84		
1	6T-5133		GASKET		6.32	6.32		



Please consider recycling this invoice to support our commitment to sustainability. Switch to digital invoicing for a greener option.

E. & O.E.

ITEMS ORDERED NOT SHOWN ARE BACK ORDERED

+ NOT RETURNABLE

TERMS :
EQUIPMENT/RENTAL SALES-CASH EX WORKS
PARTS/SERVICE SALES - STRICTLY NETT 30 DAYS

BANKING DETAILS : ANZ BANK MELBOURNE
BSB : 013 128
ACCOUNT NO : 837 249 625
REFERENCE : 306150
EMAIL YOUR REMITTANCE ADVICE TO :
CreditRegional@wadams.com.au

PAY THIS AMOUNT
Incl GST

CONT ' D

AMOUNT CREDITED
Incl GST



William Adams Pty. Ltd A.B.N. 72 009 569 493 A.C.N. 009 569 493

HEAD OFFICE
17 - 55 Nantilla Road,
Clayton Vic 3168
Tel: (03) 9566 0666

P.O. Box 164,
Clayton Vic 3168
Fax: (03) 9561 6273

VICTORIAN BRANCHES
Bendigo: (03) 5434 2100
Dandenong: (03) 9767 3666
Geelong: (03) 5223 5223
Horsham: (03) 5362 4100
Laverton: (03) 9931 9666

Mildura: (03) 5018 6100
Portland: (03) 5521 5110
Swan Hill: (03) 5036 3900
Traralgon: (03) 5175 6200
Wodonga: (02) 6051 5800

TASMANIAN BRANCHES
Hobart: (03) 6249 0566
Launceston: (03) 6325 0900
Burnie: (03) 6433 8888

SOLD TO:

**GARRAWAY EARTHMOVING PTY LTD TRADING AS
GARRAWAY GROUP
PO BOX 3378
MILDURA VIC 3502**

SHIP TO:

**Horsham
81-83 Dimboola Road
Horsham
VIC 3402 AU**

INVOICE No.	INVOICE DATE	CUSTOMER No.	CUSTOMER ORDER No.	STORE	DIV	SALESPERSON	T.C.	PAGE
P2PR0364962	19-12-23	306150	SC09/Dion	05	G		2	3
DOCUMENT No.	DOCUMENT DATE	PC	LC	MC	SHIP VIA			A.B.N.
05C217771A	15-12-23	10		10	EXPRESS OUTBND			54 098 851 631
MAKE	MODEL	SERIAL NUMBER		EQUIPMENT NUMBER	METER READING		MACH. ID No.	
AA	627G	0DBD00838		SC09				

QUANTITY	ITEM	NR	DESCRIPTION	UNIT PRICE	EXTENSION
1	3S-1284		RING	62.75	62.75
4	6Y-5888		*RING SEAL	149.04	596.16
3	330-8196		SEAL-O-RING	8.14	24.42
4	3S-1278		RING	63.18	252.72
2	1S-9496		RING	58.33	116.66
1	8S-0626		GASKET	25.76	25.76
3	100-4083		*KIT SEAL	33.22	99.66
1	3S-1283		RING	49.61	49.61
1	4S-5805		SEAL O RING	25.81	25.81
1	7G-1594		GASKET	12.46	12.46
3	8M-5007		SEAL O RIN	19.86	59.58
1	1S-7347		RING	58.83	58.83
2	3S-1281		RING	56.85	113.70
12	361-8205		SEAL-FUEL SY	12.75	153.00
1	2M-1309		SEAL O RING	18.33	18.33
28	238-5078		SEAL-O-RING	6.47	181.16
1	4S-5804		SEAL-O-RING	30.43	30.43
7	8L-2777		O RING	8.18	57.26
1	9W-3465		GASKET	30.51	30.51
5	1P-4110		DISC A CLTCH	347.86	1739.30
7	368-0297		PLATE	617.04	4319.28
1	3S-0040		PLATE	606.85	606.85
2	9P-4251		DISC A	295.19	590.38
3	3S-0044		PLATE	528.79	1586.37
3	9W-4662		DISC	196.07	588.21
55	9M-6193		SPRING A	5.88	323.40
2	4S-8724		DISC A	192.38	384.76
6	389-2007		DISC-FRICTIO	295.19	1771.14

Replaces Part # (7T2336)



Please consider recycling this invoice to support our commitment to sustainability. Switch to digital invoicing for a greener option.

E. & O.E.

ITEMS ORDERED NOT SHOWN ARE BACK ORDERED

+ NOT RETURNABLE

TERMS :
EQUIPMENT/RENTAL SALES-CASH EX WORKS
PARTS/SERVICE SALES - STRICTLY NETT 30 DAYS

BANKING DETAILS : ANZ BANK MELBOURNE
BSB : 013 128
ACCOUNT NO : 837 249 625
REFERENCE : 306150
EMAIL YOUR REMITTANCE ADVICE TO :
CreditRegional@wadams.com.au

PAY THIS AMOUNT
Incl GST

CONT ' D

AMOUNT CREDITED
Incl GST

William Adams



TAX INVOICE

William Adams Pty. Ltd A.B.N. 72 009 569 493 A.C.N. 009 569 493

HEAD OFFICE
17 - 55 Nantilla Road,
Clayton Vic 3168
Tel: (03) 9566 0666

P.O. Box 164,
Clayton Vic 3168
Fax: (03) 9561 6273

VICTORIAN BRANCHES
Bendigo: (03) 5434 2100
Dandenong: (03) 9767 3666
Geelong: (03) 5223 5223
Horsham: (03) 5362 4100
Laverton: (03) 9931 9666

Mildura: (03) 5018 6100
Portland: (03) 5521 5110
Swan Hill: (03) 5036 3900
Traralgon: (03) 5175 6200
Wodonga: (02) 6051 5800

TASMANIAN BRANCHES
Hobart: (03) 6249 0566
Launceston: (03) 6325 0900
Burnie: (03) 6433 8888

SOLD TO:

GARRAWAY EARTHMOVING PTY LTD TRADING AS
GARRAWAY GROUP
PO BOX 3378
MILDURA VIC 3502

SHIP TO:

Horsham
81-83 Dimboola Road
Horsham
VIC 3402 AU

INVOICE No.	INVOICE DATE	CUSTOMER No.	CUSTOMER ORDER No.	STORE	DIV	SALESPERSON	T.C.	PAGE
P2PR0364962	19-12-23	306150	SC09/Dion	05	G		2	4
DOCUMENT No.	DOCUMENT DATE	PC	LC	MC	SHIP VIA			A.B.N.
05C217771A	15-12-23	10		10	EXPRESS OUTBND			54 098 851 631
MAKE	MODEL	SERIAL NUMBER		EQUIPMENT NUMBER	METER READING		MACH. ID No.	
AA	627G	0DBD00838		SC09				
QUANTITY	ITEM	NR	DESCRIPTION		UNIT PRICE	EXTENSION		

TOTAL PARTS 23489.38 T

Subtotal before taxes 23489.38
G.S.T. 2348.94 T

DavidMcQueen@wadams.com.au

* * *

INVOICE COPY

* * *



Please consider recycling this invoice to support our commitment to sustainability. Switch to digital invoicing for a greener option.

E. & O.E.

ITEMS ORDERED NOT SHOWN ARE BACK ORDERED

+ NOT RETURNABLE

TERMS :
EQUIPMENT/RENTAL SALES-CASH EX WORKS
PARTS/SERVICE SALES - STRICTLY NETT 30 DAYS

BANKING DETAILS : ANZ BANK MELBOURNE
BSB : 013 128
ACCOUNT NO : 837 249 625
REFERENCE : 306150
EMAIL YOUR REMITTANCE ADVICE TO :
CreditRegional@wadams.com.au

PAY THIS AMOUNT
Incl GST AUD 25838.32

AMOUNT CREDITED
Incl GST

WA24

William Adams Pty Ltd's Standard Conditions of Quotation and Sale apply to this transaction. They can be obtained at www.williamadams.com.au/termsandconditions or by calling (03) 9566 0666 Thank You for choosing William Adams. Help us improve via FEEDBACK@WADAMS.COM.AU

William Adams



TAX INVOICE

William Adams Pty. Ltd A.B.N. 72 009 569 493 A.C.N. 009 569 493

HEAD OFFICE
17 - 55 Nantilla Road,
Clayton Vic 3168
Tel: (03) 9566 0666

P.O. Box 164,
Clayton Vic 3168
Fax: (03) 9561 6273

VICTORIAN BRANCHES
Bendigo: (03) 5434 2100
Dandenong: (03) 9767 3666
Geelong: (03) 5223 5223
Horsham: (03) 5362 4100
Laverton: (03) 9931 9666

Mildura: (03) 5018 6100
Portland: (03) 5521 5110
Swan Hill: (03) 5036 3900
Traralgon: (03) 5175 6200
Wodonga: (02) 6051 5800

TASMANIAN BRANCHES
Hobart: (03) 6249 0566
Launceston: (03) 6325 0900
Burnie: (03) 6433 8888

SOLD TO:

GARRAWAY EARTHMOVING PTY LTD TRADING AS
GARRAWAY GROUP
PO BOX 3378
MILDURA VIC 3502

SHIP TO:

Horsham
81-83 Dimboola Road
Horsham
VIC 3402 AU

INVOICE No.	INVOICE DATE	CUSTOMER No.	CUSTOMER ORDER No.	STORE	DIV	SALESPERSON	T.C.	PAGE
P2PR0367401	02-01-24	306150	SC09/Dion	05	G		2	1
DOCUMENT No.	DOCUMENT DATE	PC	LC	MC	SHIP VIA			A.B.N.
05C217771B	19-12-23	10		10	EXPRESS OUTBND			54 098 851 631
MAKE	MODEL	SERIAL NUMBER		EQUIPMENT NUMBER	METER READING		MACH. ID No.	
AA	627G	0DBD00838		SC09				
QUANTITY	ITEM	NR	DESCRIPTION		UNIT PRICE	EXTENSION		

PARTS SALES PERSON: COMMERCE ORDER

1	0R-4783		PUMP GP GEAR	N	1789.71	1789.71
1	0R-4783		CORE DEPOSIT	N	963.68	963.68
			TOTAL PARTS			2753.39 T

Subtotal before taxes	2753.39
G.S.T.	275.34 T

DavidMcQueen@wadams.com.au

* * *

INVOICE COPY

* * *



Please consider recycling this invoice to support our commitment to sustainability. Switch to digital invoicing for a greener option.

E. & O.E.

ITEMS ORDERED NOT SHOWN ARE BACK ORDERED

+ NOT RETURNABLE

TERMS :
EQUIPMENT/RENTAL SALES-CASH EX WORKS
PARTS/SERVICE SALES - STRICTLY NETT 30 DAYS

BANKING DETAILS : ANZ BANK MELBOURNE
BSB : 013 128
ACCOUNT NO : 837 249 625
REFERENCE : 306150
EMAIL YOUR REMITTANCE ADVICE TO :
CreditRegional@wadams.com.au

PAY THIS AMOUNT Incl GST	AUD	3028.73
-----------------------------	-----	---------

AMOUNT CREDITED Incl GST	
-----------------------------	--

WA24

William Adams Pty Ltd's Standard Conditions of Quotation and Sale apply to this transaction. They can be obtained at www.williamadams.com.au/termsandconditions or by calling (03) 9566 0666 Thank You for choosing William Adams. Help us improve via FEEDBACK@WADAMS.COM.AU

William Adams



TAX INVOICE

William Adams Pty. Ltd A.B.N. 72 009 569 493 A.C.N. 009 569 493

HEAD OFFICE
17 - 55 Nantilla Road,
Clayton Vic 3168
Tel: (03) 9566 0666

P.O. Box 164,
Clayton Vic 3168
Fax: (03) 9561 6273

VICTORIAN BRANCHES
Bendigo: (03) 5434 2100
Dandenong: (03) 9767 3666
Geelong: (03) 5223 5223
Horsham: (03) 5362 4100
Laverton: (03) 9931 9666

Mildura: (03) 5018 6100
Portland: (03) 5521 5110
Swan Hill: (03) 5036 3900
Traralgon: (03) 5175 6200
Wodonga: (02) 6051 5800

TASMANIAN BRANCHES
Hobart: (03) 6249 0566
Launceston: (03) 6325 0900
Burnie: (03) 6433 8888

SOLD TO:

GARRAWAY EARTHMOVING PTY LTD TRADING AS
GARRAWAY GROUP
PO BOX 3378
MILDURA VIC 3502

SHIP TO:

Horsham
81-83 Dimboola Road
Horsham
VIC 3402 AU

INVOICE No.	INVOICE DATE	CUSTOMER No.	CUSTOMER ORDER No.	STORE	DIV	SALESPERSON	T.C.	PAGE
P2PR0367402	02-01-24	306150	SC09/Dion	05	G		2	1
DOCUMENT No.	DOCUMENT DATE	PC	LC	MC	SHIP VIA			A.B.N.
05C217771C	02-01-24	10		10	EXPRESS OUTBND			54 098 851 631
MAKE	MODEL	SERIAL NUMBER		EQUIPMENT NUMBER	METER READING		MACH. ID No.	
AA	627G	0DBD00838		SC09				
QUANTITY	ITEM	NR	DESCRIPTION		UNIT PRICE	EXTENSION		

PARTS SALES PERSON: COMMERCE ORDER

1	0R-4782		PUMP GP GEAR	N	1921.43	1921.43
1	0R-4782		CORE DEPOSIT	N	1034.60	1034.60
			TOTAL PARTS			2956.03 T

Subtotal before taxes 2956.03

G.S.T. 295.60 T

DavidMcQueen@wadams.com.au

* * *

INVOICE COPY

* * *



Please consider recycling this invoice to support our commitment to sustainability. Switch to digital invoicing for a greener option.

E. & O.E.

ITEMS ORDERED NOT SHOWN ARE BACK ORDERED

+ NOT RETURNABLE

TERMS :
EQUIPMENT/RENTAL SALES-CASH EX WORKS
PARTS/SERVICE SALES - STRICTLY NETT 30 DAYS

BANKING DETAILS : ANZ BANK MELBOURNE
BSB : 013 128
ACCOUNT NO : 837 249 625
REFERENCE : 306150
EMAIL YOUR REMITTANCE ADVICE TO :
CreditRegional@wadams.com.au

PAY THIS AMOUNT
Incl GST AUD 3251.63

AMOUNT CREDITED
Incl GST

WA24

William Adams Pty Ltd's Standard Conditions of Quotation and Sale apply to this transaction. They can be obtained at www.williamadams.com.au/termsandconditions or by calling (03) 9566 0666 Thank You for choosing William Adams. Help us improve via FEEDBACK@WADAMS.COM.AU



William Adams Pty. Ltd A.B.N. 72 009 569 493 A.C.N. 009 569 493

HEAD OFFICE
17 - 55 Nantilla Road,
Clayton Vic 3168
Tel: (03) 9566 0666

P.O. Box 164,
Clayton Vic 3168
Fax: (03) 9561 6273

VICTORIAN BRANCHES
Bendigo: (03) 5434 2100
Dandenong: (03) 9767 3666
Geelong: (03) 5223 5223
Horsham: (03) 5362 4100
Laverton: (03) 9931 9666

Mildura: (03) 5018 6100
Portland: (03) 5521 5110
Swan Hill: (03) 5036 3900
Traralgon: (03) 5175 6200
Wodonga: (02) 6051 5800

TASMANIAN BRANCHES
Hobart: (03) 6249 0566
Launceston: (03) 6325 0900
Burnie: (03) 6433 8888

SOLD TO:

**GARRAWAY EARTHMOVING PTY LTD TRADING AS
GARRAWAY GROUP
PO BOX 3378
MILDURA VIC 3502**

SHIP TO:

**Mildura
345 Benetook Avenue
Mildura
VIC 3502 AU**

INVOICE No.	INVOICE DATE	CUSTOMER No.	CUSTOMER ORDER No.	STORE	DIV	SALESPERSON	T.C.	PAGE
P2PR0367628	03-01-24	306150	SC09 FRONT TRANS	05	G		2	1
DOCUMENT No.	DOCUMENT DATE	PC	LC	MC	SHIP VIA			A.B.N.
05C217888A	02-01-24	10		10				54 098 851 631
MAKE	MODEL	SERIAL NUMBER		EQUIPMENT NUMBER	METER READING		MACH. ID No.	
QUANTITY	ITEM	NR	DESCRIPTION		UNIT PRICE	EXTENSION		

PARTS SALES PERSON: COMMERCE ORDER

2	1S-3725		COVER	N	61.42	122.84
2	8E-7366		GASKET	N	8.43	16.86
1	2P-7023		SHIM PACK	N	187.06	187.06
1	5H-6199		RING	N	8.28	8.28
1	3K-0526		BEARING	N	97.78	97.78
1	1B-3867		BEARING	N	50.06	50.06
1	8H-3981		RING	N	3.51	3.51
1	201-6615		SENSOR GP-SPEED	S	276.49	276.49
1	9M-1975		RING	N	3.69	3.69
1	3H-1816		RING-RETAINING	N	5.60	5.60
1	1T-0649		RING-RETAINING	N	13.26	13.26
1	1T-0762		RACE-THRUST BEARIN	N	80.60	80.60
1	8B-7789		RING-SNAP	N	24.13	24.13
1	6P-1037		RING	N	2.64	2.64
1	5S-7779		RING	N	12.00	12.00
1	3S-2619		RING	N	6.46	6.46
1	1M-8649		RING-RETAINING	N	43.06	43.06
30	4M-9592		SPRING	N	12.07	362.10
10	1M-9691		SPRING	N	17.06	170.60
15	2S-0044		PIN	N	22.83	342.45
3	1M-8652		RING	N	26.40	79.20
1	8M-1112		SEAL O RIN	N	6.18	6.18
1	4S-5805		SEAL O RING	N	26.56	26.56
1	7G-2500		GEAR PLANET	N	413.42	413.42
4	5M-6212		TUBE	N	21.14	84.56
2	1S-9496		RING	N	59.97	119.94
1	6H-7201		RING	N	14.68	14.68



Please consider recycling this invoice to support our commitment to sustainability. Switch to digital invoicing for a greener option.

E. & O.E.

ITEMS ORDERED NOT SHOWN ARE BACK ORDERED

+ NOT RETURNABLE

TERMS :
EQUIPMENT/RENTAL SALES-CASH EX WORKS
PARTS/SERVICE SALES - STRICTLY NETT 30 DAYS

BANKING DETAILS : ANZ BANK MELBOURNE
BSB : 013 128
ACCOUNT NO : 837 249 625
REFERENCE : 306150
EMAIL YOUR REMITTANCE ADVICE TO :
CreditRegional@wadams.com.au

PAY THIS AMOUNT
Incl GST

CONT ' D

AMOUNT CREDITED
Incl GST



William Adams Pty. Ltd A.B.N. 72 009 569 493 A.C.N. 009 569 493

HEAD OFFICE
17 - 55 Nantilla Road,
Clayton Vic 3168
Tel: (03) 9566 0666

P.O. Box 164,
Clayton Vic 3168
Fax: (03) 9561 6273

VICTORIAN BRANCHES
Bendigo: (03) 5434 2100
Dandenong: (03) 9767 3666
Geelong: (03) 5223 5223
Horsham: (03) 5362 4100
Laverton: (03) 9931 9666

Mildura: (03) 5018 6100
Portland: (03) 5521 5110
Swan Hill: (03) 5036 3900
Traralgon: (03) 5175 6200
Wodonga: (02) 6051 5800

TASMANIAN BRANCHES
Hobart: (03) 6249 0566
Launceston: (03) 6325 0900
Burnie: (03) 6433 8888

SOLD TO:

**GARRAWAY EARTHMOVING PTY LTD TRADING AS
GARRAWAY GROUP
PO BOX 3378
MILDURA VIC 3502**

SHIP TO:

**Mildura
345 Benetook Avenue
Mildura
VIC 3502 AU**

INVOICE No.	INVOICE DATE	CUSTOMER No.	CUSTOMER ORDER No.	STORE	DIV	SALESPERSON	T.C.	PAGE
P2PR0367628	03-01-24	306150	SC09 FRONT TRANS	05	G		2	2
DOCUMENT No.	DOCUMENT DATE	PC	LC	MC	SHIP VIA			A.B.N.
05C217888A	02-01-24	10		10				54 098 851 631
MAKE	MODEL	SERIAL NUMBER		EQUIPMENT NUMBER	METER READING		MACH. ID No.	

QUANTITY	ITEM	NR	DESCRIPTION	UNIT PRICE	EXTENSION	
1	6T-5613		SPACER N	80.58	80.58	
5	6T-5612		GROMMET N	7.11	35.55	
1	2M-1309		SEAL O RING N	18.86	18.86	
4	9S-8001		PLUG N	7.33	29.32	
2	302-3813		VALVE GP-SOL N	469.88	939.76	
Replaces Part # (1938559)						
6	1S-7462		SEAL N	5.54	33.24	
4	8M-4432		SEAL O RING S	6.83	27.32	
1	1T-0648		*SEAL R METAL N	26.93	26.93	
1	1T-0651		RING N	18.40	18.40	
1	9W-6964		VALVE AS-EXHAUST N	44.99	44.99	
7	4B-9880		BALL N	.61	4.27	
4	9W-7410		SPRING N	23.24	92.96	
4	5J-2721		SHIM N	2.78	11.12	
4	5J-1036		SHIM N	2.89	11.56	
7	8L-2777		O RING N	8.43	59.01	
2	9W-7412		SPRING N	23.01	46.02	
TOTAL PARTS					4053.90	T

Subtotal before taxes 4053.90
G.S.T. 405.39 T

howorkshop@garraway.com.au
PLEASE HOLD FOR DION

* * *

INVOICE COPY

* * *



Please consider recycling this invoice to support our commitment to sustainability. Switch to digital invoicing for a greener option.

E. & O.E.

ITEMS ORDERED NOT SHOWN ARE BACK ORDERED

+ NOT RETURNABLE

TERMS :
EQUIPMENT/RENTAL SALES-CASH EX WORKS
PARTS/SERVICE SALES - STRICTLY NETT 30 DAYS

BANKING DETAILS : ANZ BANK MELBOURNE
BSB : 013 128
ACCOUNT NO : 837 249 625
REFERENCE : 306150
EMAIL YOUR REMITTANCE ADVICE TO :
CreditRegional@wadams.com.au

PAY THIS AMOUNT
Incl GST AUD 4459.29

AMOUNT CREDITED
Incl GST



William Adams Pty. Ltd A.B.N. 72 009 569 493 A.C.N. 009 569 493

HEAD OFFICE
17 - 55 Nantilla Road,
Clayton Vic 3168
Tel: (03) 9566 0666

P.O. Box 164,
Clayton Vic 3168
Fax: (03) 9561 6273

VICTORIAN BRANCHES
Bendigo: (03) 5434 2100
Dandenong: (03) 9767 3666
Geelong: (03) 5223 5223
Horsham: (03) 5362 4100
Laverton: (03) 9931 9666

Mildura: (03) 5018 6100
Portland: (03) 5521 5110
Swan Hill: (03) 5036 3900
Traralgon: (03) 5175 6200
Wodonga: (02) 6051 5800

TASMANIAN BRANCHES
Hobart: (03) 6249 0566
Launceston: (03) 6325 0900
Burnie: (03) 6433 8888

SOLD TO:

**GARRAWAY EARTHMOVING PTY LTD TRADING AS
GARRAWAY GROUP
PO BOX 3378
MILDURA VIC 3502**

SHIP TO:

**Mildura
345 Benetook Avenue
Mildura
VIC 3502 AU**

INVOICE No.	INVOICE DATE	CUSTOMER No.	CUSTOMER ORDER No.	STORE	DIV	SALESPERSON	T.C.	PAGE
P2PR0367947	04-01-24	306150	SC09 FRONT TRANS	05	G		2	1
DOCUMENT No.	DOCUMENT DATE	PC	LC	MC	SHIP VIA			A.B.N.
05C217888B	03-01-24	10		10				54 098 851 631
MAKE	MODEL	SERIAL NUMBER		EQUIPMENT NUMBER	METER READING		MACH. ID No.	
QUANTITY	ITEM	NR	DESCRIPTION		UNIT PRICE	EXTENSION		

PARTS SALES PERSON: COMMERCE ORDER

2	8S-0615		SHIM PACK	N	326.69	653.38
1	2K-5967		RING	N	10.83	10.83
5	4M-1677		PIN	N	30.76	153.80
5	4M-1641		PIN	N	29.47	147.35
5	6F-6678		SPRING	N	14.68	73.40
1	3D-2907		RING-RETAINING	N	9.94	9.94
1	8S-9181		GEAR	N	413.42	413.42
1	8S-9182		RING	N	10.71	10.71
2	7G-2501		GEAR PLANET	N	308.71	617.42
2	7G-2500		GEAR PLANET	N	413.42	826.84
1	3S-1395		GEAR	N	611.47	611.47
2	7G-2512		GEAR PLANET	N	356.31	712.62
1	3S-1394		GEAR	N	901.36	901.36
5	4M-8871		DOWEL	N	18.22	91.10
1	9S-8839		GEAR	N	641.97	641.97
3	7G-2489		GEAR PLANET	N	337.47	1012.41
3	7G-2499		GEAR PLANET	N	375.40	1126.20
6	1S-7462		SEAL	N	5.54	33.24
7	5M-2504		SLUG	N	11.60	81.20
7	9P-0683		SPRING	N	24.49	171.43
7	1S-1636		RETAINER	N	8.65	60.55
7	1S-1638		RING	N	.81	5.67
3	7T-0571		SPRING	N	17.47	52.41
4	6J-3993		SHIM	N	2.81	11.24
7	9D-7884		SPRING	N	14.50	101.50
3	7T-0569		SPRING	N	17.44	52.32



Please consider recycling this invoice to support our commitment to sustainability. Switch to digital invoicing for a greener option.

E. & O.E.

ITEMS ORDERED NOT SHOWN ARE BACK ORDERED

+ NOT RETURNABLE

TERMS :
EQUIPMENT/RENTAL SALES-CASH EX WORKS
PARTS/SERVICE SALES - STRICTLY NETT 30 DAYS

BANKING DETAILS : ANZ BANK MELBOURNE
BSB : 013 128
ACCOUNT NO : 837 249 625
REFERENCE : 306150
EMAIL YOUR REMITTANCE ADVICE TO :
CreditRegional@wadams.com.au

PAY THIS AMOUNT
Incl GST

CONT ' D

AMOUNT CREDITED
Incl GST

William Adams



TAX INVOICE

William Adams Pty. Ltd A.B.N. 72 009 569 493 A.C.N. 009 569 493

HEAD OFFICE
17 - 55 Nantilla Road,
Clayton Vic 3168
Tel: (03) 9566 0666

P.O. Box 164,
Clayton Vic 3168
Fax: (03) 9561 6273

VICTORIAN BRANCHES
Bendigo: (03) 5434 2100
Dandenong: (03) 9767 3666
Geelong: (03) 5223 5223
Horsham: (03) 5362 4100
Laverton: (03) 9931 9666

Mildura: (03) 5018 6100
Portland: (03) 5521 5110
Swan Hill: (03) 5036 3900
Traralgon: (03) 5175 6200
Wodonga: (02) 6051 5800

TASMANIAN BRANCHES
Hobart: (03) 6249 0566
Launceston: (03) 6325 0900
Burnie: (03) 6433 8888

SOLD TO:

GARRAWAY EARTHMOVING PTY LTD TRADING AS
GARRAWAY GROUP
PO BOX 3378
MILDURA VIC 3502

SHIP TO:

Mildura
345 Benetook Avenue
Mildura
VIC 3502 AU

INVOICE No.	INVOICE DATE	CUSTOMER No.	CUSTOMER ORDER No.	STORE	DIV	SALESPERSON	T.C.	PAGE
P2PR0367947	04-01-24	306150	SC09 FRONT TRANS	05	G		2	2
DOCUMENT No.	DOCUMENT DATE	PC	LC	MC	SHIP VIA			A.B.N.
05C217888B	03-01-24	10		10				54 098 851 631
MAKE	MODEL	SERIAL NUMBER		EQUIPMENT NUMBER	METER READING		MACH. ID No.	
QUANTITY	ITEM	NR	DESCRIPTION			UNIT PRICE	EXTENSION	

TOTAL PARTS 8583.78 T

Subtotal before taxes 8583.78
G.S.T. 858.38 T

howorkshop@garraway.com.au
PLEASE HOLD FOR DION

* * *

INVOICE COPY

* * *



Please consider recycling this invoice to support our commitment to sustainability. Switch to digital invoicing for a greener option.

E. & O.E.

ITEMS ORDERED NOT SHOWN ARE BACK ORDERED

+ NOT RETURNABLE

TERMS :
EQUIPMENT/RENTAL SALES-CASH EX WORKS
PARTS/SERVICE SALES - STRICTLY NETT 30 DAYS

BANKING DETAILS : ANZ BANK MELBOURNE
BSB : 013 128
ACCOUNT NO : 837 249 625
REFERENCE : 306150
EMAIL YOUR REMITTANCE ADVICE TO :
CreditRegional@wadams.com.au

PAY THIS AMOUNT
Incl GST AUD 9442.16

AMOUNT CREDITED
Incl GST

WA24

William Adams Pty Ltd's Standard Conditions of Quotation and Sale apply to this transaction. They can be obtained at www.williamadams.com.au/termsandconditions or by calling (03) 9566 0666 Thank You for choosing William Adams. Help us improve via FEEDBACK@WADAMS.COM.AU

William Adams



TAX INVOICE

William Adams Pty. Ltd A.B.N. 72 009 569 493 A.C.N. 009 569 493

HEAD OFFICE
17 - 55 Nantilla Road,
Clayton Vic 3168
Tel: (03) 9566 0666

P.O. Box 164,
Clayton Vic 3168
Fax: (03) 9561 6273

VICTORIAN BRANCHES
Bendigo: (03) 5434 2100
Dandenong: (03) 9767 3666
Geelong: (03) 5223 5223
Horsham: (03) 5362 4100
Laverton: (03) 9931 9666

Mildura: (03) 5018 6100
Portland: (03) 5521 5110
Swan Hill: (03) 5036 3900
Traralgon: (03) 5175 6200
Wodonga: (02) 6051 5800

TASMANIAN BRANCHES
Hobart: (03) 6249 0566
Launceston: (03) 6325 0900
Burnie: (03) 6433 8888

SOLD TO:

GARRAWAY EARTHMOVING PTY LTD TRADING AS
GARRAWAY GROUP
PO BOX 3378
MILDURA VIC 3502

SHIP TO:

Horsham
81-83 Dimboola Road
Horsham
VIC 3402 AU

INVOICE No.	INVOICE DATE	CUSTOMER No.	CUSTOMER ORDER No.	STORE	DIV	SALESPERSON	T.C.	PAGE
P2PR0376483	30-01-24	306150	sc09	05	G		2	1
DOCUMENT No.	DOCUMENT DATE	PC	LC	MC	SHIP VIA			A.B.N.
05C218227A	29-01-24	10		10	EFP EXPRESS			54 098 851 631
MAKE	MODEL	SERIAL NUMBER		EQUIPMENT NUMBER	METER READING		MACH. ID No.	
QUANTITY	ITEM	NR	DESCRIPTION			UNIT PRICE	EXTENSION	

PARTS SALES PERSON: COMMERCE ORDER

2	7S-8767		*GASKET	N		9.58	19.16	
1	0R-3366		CORE GP-OIL CLR	N		5033.31	5033.31	
1	0R-3366		CORE DEPOSIT	N		2055.89	2055.89	
TOTAL PARTS							7108.36	T

Subtotal before taxes 7108.36

G.S.T. 710.84 T

dgworkshop@garraway.com.au

please emergency cooler out of CAT for tomorrow

E. & O.E.

ITEMS ORDERED NOT SHOWN ARE BACK ORDERED

+ NOT RETURNABLE

TERMS :
EQUIPMENT/RENTAL SALES-CASH EX WORKS
PARTS/SERVICE SALES - STRICTLY NETT 30 DAYS

BANKING DETAILS : ANZ BANK MELBOURNE
BSB : 013 128
ACCOUNT NO : 837 249 625
REFERENCE : 306150
EMAIL YOUR REMITTANCE ADVICE TO :
CreditHorsham@wadams.com.au

PAY THIS AMOUNT
Incl GST AUD 7819.20

AMOUNT CREDITED
Incl GST

WA15

William Adams Pty Ltd's Standard Conditions of Quotation and Sale apply to this transaction.
They can be obtained at www.williamadams.com.au/termsandconditions or by calling (03) 9566 0666
Thank You for choosing William Adams. Help us improve via FEEDBACK@WADAMS.COM.AU

William Adams



TAX INVOICE

William Adams Pty. Ltd A.B.N. 72 009 569 493 A.C.N. 009 569 493

HEAD OFFICE
17 - 55 Nantilla Road,
Clayton Vic 3168
Tel: (03) 9566 0666

P.O. Box 164,
Clayton Vic 3168
Fax: (03) 9561 6273

VICTORIAN BRANCHES
Bendigo: (03) 5434 2100
Dandenong: (03) 9767 3666
Geelong: (03) 5223 5223
Horsham: (03) 5362 4100
Laverton: (03) 9931 9666

Mildura: (03) 5018 6100
Portland: (03) 5521 5110
Swan Hill: (03) 5036 3900
Traralgon: (03) 5175 6200
Wodonga: (02) 6051 5800

TASMANIAN BRANCHES
Hobart: (03) 6249 0566
Launceston: (03) 6325 0900
Burnie: (03) 6433 8888

SOLD TO:

GARRAWAY EARTHMOVING PTY LTD TRADING AS
GARRAWAY GROUP
PO BOX 3378
MILDURA VIC 3502

SHIP TO:

Horsham
81-83 Dimboola Road
Horsham
VIC 3402 AU

INVOICE No.	INVOICE DATE	CUSTOMER No.	CUSTOMER ORDER No.	STORE	DIV	SALESPERSON	T.C.	PAGE
P2PR0382204	13-02-24	306150	Dion SC09	05	G		2	1
DOCUMENT No.	DOCUMENT DATE	PC	LC	MC	SHIP VIA			A.B.N.
05C218439A	09-02-24	10		10	STOCK(X-ORDER)			54 098 851 631
MAKE	MODEL	SERIAL NUMBER		EQUIPMENT NUMBER	METER READING		MACH. ID No.	
AA	627G	0DBD00838		SC09				
QUANTITY	ITEM	NR	DESCRIPTION		UNIT PRICE	EXTENSION		
PARTS SALES PERSON: COMMERCE ORDER								
1	7N-9650		FLYWHEEL ASS		N	3642.03	3642.03	
			TOTAL PARTS				3642.03 T	
			Subtotal before taxes				3642.03	
			G.S.T.				364.20 T	
JasonDiPietro@wadams.com.au Dion to collect								
E. & O.E.			ITEMS ORDERED NOT SHOWN ARE BACK ORDERED			+ NOT RETURNABLE		

TERMS :
EQUIPMENT/RENTAL SALES-CASH EX WORKS
PARTS/SERVICE SALES - STRICTLY NETT 30 DAYS

BANKING DETAILS : ANZ BANK MELBOURNE
BSB : 013 128
ACCOUNT NO : 837 249 625
REFERENCE : 306150
EMAIL YOUR REMITTANCE ADVICE TO :
CreditHorsham@wadams.com.au

PAY THIS AMOUNT
Incl GST AUD 4006.23

AMOUNT CREDITED
Incl GST

WA15

William Adams Pty Ltd's Standard Conditions of Quotation and Sale apply to this transaction.
They can be obtained at www.williamadams.com.au/termsandconditions or by calling (03) 9566 0666
Thank You for choosing William Adams. Help us improve via FEEDBACK@WADAMS.COM.AU

William Adams**TAX INVOICE**

William Adams Pty. Ltd A.B.N. 72 009 569 493 A.C.N. 009 569 493

HEAD OFFICE
17 - 55 Nantilla Road,
Clayton Vic 3168
Tel: (03) 9566 0666P.O. Box 164,
Clayton Vic 3168
Fax: (03) 9561 6273**VICTORIAN BRANCHES**
Bendigo: (03) 5434 2100
Dandenong: (03) 9767 3666
Geelong: (03) 5223 5223
Horsham: (03) 5362 4100
Laverton: (03) 9931 9666Mildura: (03) 5018 6100
Portland: (03) 5521 5110
Swan Hill: (03) 5036 3900
Traralgon: (03) 5175 6200
Wodonga: (02) 6051 5800**TASMANIAN BRANCHES**
Hobart: (03) 6249 0566
Launceston: (03) 6325 0900
Burnie: (03) 6433 8888

SOLD TO:

**GARRAWAY EARTHMOVING PTY LTD TRADING AS
GARRAWAY GROUP
PO BOX 3378
MILDURA VIC 3502**

SHIP TO:

**Russell Garraway
C/O Ouyen and district freight
Ouyen Vic 3490**

INVOICE No.	INVOICE DATE	CUSTOMER No.	CUSTOMER ORDER No.	STORE	DIV	SALESPERSON	T.C.	PAGE
PR000708196	07-03-18	306150	SC09WRP	00	G		2	1
DOCUMENT No.	DOCUMENT DATE	PC	LC	MC	SHIP VIA			A.B.N.
00C684487	06-03-18	10		10				54 098 851 631
MAKE	MODEL	SERIAL NUMBER		EQUIPMENT NUMBER	METER READING		MACH. ID No.	
AA		0DBZ00083						
QUANTITY	ITEM	NR	DESCRIPTION		UNIT PRICE	EXTENSION		

PARTS SALES PERSON: COMMERCE ORDER

1	387-9433		*INJECTOR GP-FUEL S		1061.26	1061.26		
1	149-5240		INJECTOR RING - BS		7.58	7.58		
1	293-0730		RING-BACKUP S		7.36	7.36		
1	109-3207		INJECTOR - SEAL OS		9.07	9.07		
2	148-2903		INJECTOR - SEAL OS		11.00	22.00		
2	235-9651		BOLT-SOCKET S		.93	1.86		
1	4C-6161		BRUSH S		7.60	7.60		
			TOTAL PARTS			1116.73 T		

Subtotal before taxes
G.S.T.1116.73
111.67 T

russell@garraway.com.au

PLEASE SEND OVERNIGHT ROAD FREIGHT TO OUYEN TNT DE
POT

ZONE 1 BY-WC4 ,ZONE 2 BY-XGL 00-ROAD-F

OUR PREFERRED METHOD OF PAYMENT IS BY EFT

OUR BANKING DETAILS ARE:

ANZ BANK MELBOURNE

BSB: 013 128

ACCOUNT NO: 837 249 625

PLEASE QUOTE YOUR CUSTOMER NO. AS THE REFERENCE AND

EMAIL YOUR REMITTANCE ADVICE TO: CREDIT@WADAMS.COM.AU

Please consider recycling this invoice to
support our commitment to sustainability.
Switch to digital invoicing for a greener option.

E. & O.E.

ITEMS ORDERED NOT SHOWN ARE BACK ORDERED

+ NOT RETURNABLE

TERMS :
EQUIPMENT/RENTAL SALES-CASH EX WORKS
PARTS/SERVICE SALES - STRICTLY NETT 30 DAYS**BANKING DETAILS : ANZ BANK MELBOURNE**
BSB : 013 128
ACCOUNT NO : 837 249 625
REFERENCE : 306150
EMAIL YOUR REMITTANCE ADVICE TO :
CreditClayton@wadams.com.auPAY THIS AMOUNT
Incl GST

CONT ' D

AMOUNT CREDITED
Incl GST

WA24

William Adams Pty Ltd's Standard Conditions of Quotation and Sale apply to this transaction.
They can be obtained at www.williamadams.com.au/termsandconditions or by calling (03) 9566 0666
Thank You for choosing William Adams. Help us improve via FEEDBACK@WADAMS.COM.AU

William Adams



TAX INVOICE

William Adams Pty. Ltd A.B.N. 72 009 569 493 A.C.N. 009 569 493

HEAD OFFICE
17 - 55 Nantilla Road,
Clayton Vic 3168
Tel: (03) 9566 0666

P.O. Box 164,
Clayton Vic 3168
Fax: (03) 9561 6273

VICTORIAN BRANCHES
Bendigo: (03) 5434 2100
Dandenong: (03) 9767 3666
Geelong: (03) 5223 5223
Horsham: (03) 5362 4100
Laverton: (03) 9931 9666

Mildura: (03) 5018 6100
Portland: (03) 5521 5110
Swan Hill: (03) 5036 3900
Traralgon: (03) 5175 6200
Wodonga: (02) 6051 5800

TASMANIAN BRANCHES
Hobart: (03) 6249 0566
Launceston: (03) 6325 0900
Burnie: (03) 6433 8888

SOLD TO:

**GARRAWAY EARTHMOVING PTY LTD TRADING AS
GARRAWAY GROUP
PO BOX 3378
MILDURA VIC 3502**

SHIP TO:

**Russell Garraway
C/O Ouyen and district freight
Ouyen Vic 3490**

INVOICE No.	INVOICE DATE	CUSTOMER No.	CUSTOMER ORDER No.	STORE	DIV	SALESPERSON	T.C.	PAGE
PR00708196	07-03-18	306150	SC09WRP	00	G		2	2
DOCUMENT No.	DOCUMENT DATE	PC	LC	MC	SHIP VIA			A.B.N.
00C684487	06-03-18	10		10				54 098 851 631
MAKE	MODEL	SERIAL NUMBER		EQUIPMENT NUMBER	METER READING		MACH. ID No.	
AA		0DBZ00083						
QUANTITY	ITEM	NR	DESCRIPTION		UNIT PRICE	EXTENSION		

THANK YOU FOR CHOOSING WILLIAM ADAMS
HELP US IMPROVE VIA FEEDBACK@WADAMS.COM.AU

BANKING DETAILS: ANZ BANK - MELBOURNE
BSB: 013 128
ACCOUNT NO: 8372 49625
REFERENCE: YOUR CUSTOMER NUMBER

EMAIL YOUR REMITTANCE ADVICE TO: CREDITCLAYTON@WADAMS.COM.AU
* * * INVOICE COPY * * *



Please consider recycling this invoice to support our commitment to sustainability. Switch to digital invoicing for a greener option.

E. & O.E.

ITEMS ORDERED NOT SHOWN ARE BACK ORDERED

+ NOT RETURNABLE

TERMS :
EQUIPMENT/RENTAL SALES-CASH EX WORKS
PARTS/SERVICE SALES - STRICTLY NETT 30 DAYS

BANKING DETAILS : ANZ BANK MELBOURNE
BSB : 013 128
ACCOUNT NO : 837 249 625
REFERENCE : 306150
EMAIL YOUR REMITTANCE ADVICE TO :
CreditClayton@wadams.com.au

PAY THIS AMOUNT
Incl GST AUD 1228.40

AMOUNT CREDITED
Incl GST

WA24

William Adams Pty Ltd's Standard Conditions of Quotation and Sale apply to this transaction.
They can be obtained at www.williamadams.com.au/termsandconditions or by calling (03) 9566 0666
Thank You for choosing William Adams. Help us improve via FEEDBACK@WADAMS.COM.AU



William Adams Pty. Ltd A.B.N. 72 009 569 493 A.C.N. 009 569 493

HEAD OFFICE
17 - 55 Nantilla Road,
Clayton Vic 3168
Tel: (03) 9566 0666

P.O. Box 164,
Clayton Vic 3168
Fax: (03) 9561 6273

VICTORIAN BRANCHES
Bendigo: (03) 5434 2100
Dandenong: (03) 9767 3666
Geelong: (03) 5223 5223
Horsham: (03) 5362 4100
Laverton: (03) 9931 9666

Mildura: (03) 5018 6100
Portland: (03) 5521 5110
Swan Hill: (03) 5036 3900
Traralgon: (03) 5175 6200
Wodonga: (02) 6051 5800

TASMANIAN BRANCHES
Hobart: (03) 6249 0566
Launceston: (03) 6325 0900
Burnie: (03) 6433 8888

SOLD TO:

**GARRAWAY EARTHMOVING PTY LTD TRADING AS
GARRAWAY GROUP
PO BOX 3378
MILDURA VIC 3502**

SHIP TO:

**Mildura
345 Benetook Avenue
Mildura
VIC 3502 AU**

INVOICE No.	INVOICE DATE	CUSTOMER No.	CUSTOMER ORDER No.	STORE	DIV	SALESPERSON	T.C.	PAGE
PR140096821	09-07-18	306150	SC09WRP	14	G		2	1
DOCUMENT No.	DOCUMENT DATE	PC	LC	MC	SHIP VIA			A.B.N.
14C084045A	07-07-18	10		10				54 098 851 631
MAKE	MODEL	SERIAL NUMBER		EQUIPMENT NUMBER	METER READING		MACH. ID No.	
AA	627G	0DBZ00839						
QUANTITY	ITEM	NR	DESCRIPTION		UNIT PRICE	EXTENSION		

PARTS SALES PERSON: COMMERCE ORDER

1	2D-5248		GASKET	N	3.81	3.81			
4	7X-7958		CLAMP-HOSE	N	12.13	48.52			
1	6D-4733		GASKET	N	4.11	4.11			
1	8M-5010		SEAL O RIN	S	7.13	7.13			
50	5P-2094		CM-HOSE STK	N	.67	33.50			
1	5J-3316		GASKET	N	39.78	39.78			
6	9X-6620		NUT	S	6.40	38.40			
6	161-3411		GASKET	N	4.92	29.52			
12	116-3715		STUD	N	15.74	188.88			
6	4P-4369		SPACER	N	16.06	96.36			
2	418-6781		STUD TAPERLO	S	26.65	53.30			
4	1P-7115		MOUNT AS	N	33.54	134.16			
2	6G-9943		BOLT	N	26.89	53.78			
1	10R-3667		CORE AS OIL	N	2178.54	2178.54			
1	10R-3667		CORE DEPOSIT	N	889.83	889.83			
1	5T-9518		HOSE AS	N	149.06	149.06			
1	5T-9520		HOSE AS	N	153.16	153.16			
1	215-8029		HOSE AS.	N	245.45	245.45			
							TOTAL PARTS	4347.29	T

Subtotal before taxes 4347.29
G.S.T. 434.73 T

russell@garraway.com.au

PLEASE ORDER AND MAKE HOSES AND SEND DOWN ON SHADO



Please consider recycling this invoice to support our commitment to sustainability. Switch to digital invoicing for a greener option.

E. & O.E.

ITEMS ORDERED NOT SHOWN ARE BACK ORDERED

+ NOT RETURNABLE

TERMS :
EQUIPMENT/RENTAL SALES-CASH EX WORKS
PARTS/SERVICE SALES - STRICTLY NETT 30 DAYS

BANKING DETAILS : ANZ BANK MELBOURNE
BSB : 013 128
ACCOUNT NO : 837 249 625
REFERENCE : 306150
EMAIL YOUR REMITTANCE ADVICE TO :
CreditRegional@wadams.com.au

PAY THIS AMOUNT
Incl GST

CONT ' D

AMOUNT CREDITED
Incl GST

William Adams



TAX INVOICE

William Adams Pty. Ltd A.B.N. 72 009 569 493 A.C.N. 009 569 493

HEAD OFFICE
17 - 55 Nantilla Road,
Clayton Vic 3168
Tel: (03) 9566 0666

P.O. Box 164,
Clayton Vic 3168
Fax: (03) 9561 6273

VICTORIAN BRANCHES
Bendigo: (03) 5434 2100
Dandenong: (03) 9767 3666
Geelong: (03) 5223 5223
Horsham: (03) 5362 4100
Laverton: (03) 9931 9666

Mildura: (03) 5018 6100
Portland: (03) 5521 5110
Swan Hill: (03) 5036 3900
Traralgon: (03) 5175 6200
Wodonga: (02) 6051 5800

TASMANIAN BRANCHES
Hobart: (03) 6249 0566
Launceston: (03) 6325 0900
Burnie: (03) 6433 8888

SOLD TO:

**GARRAWAY EARTHMOVING PTY LTD TRADING AS
GARRAWAY GROUP
PO BOX 3378
MILDURA VIC 3502**

SHIP TO:

**Mildura
345 Benetook Avenue
Mildura
VIC 3502 AU**

INVOICE No.	INVOICE DATE	CUSTOMER No.	CUSTOMER ORDER No.	STORE	DIV	SALESPERSON	T.C.	PAGE
PR140096821	09-07-18	306150	SC09WRP	14	G		2	2
DOCUMENT No.	DOCUMENT DATE	PC	LC	MC	SHIP VIA			A.B.N.
14C084045A	07-07-18	10		10				54 098 851 631
MAKE	MODEL	SERIAL NUMBER		EQUIPMENT NUMBER	METER READING		MACH. ID No.	
AA	627G	0DBZ00839						
QUANTITY	ITEM	NR	DESCRIPTION		UNIT PRICE	EXTENSION		

CKS TO OUYEN CHEERS
 OUR PREFERRED METHOD OF PAYMENT IS BY EFT
 OUR BANKING DETAILS ARE:
 ANZ BANK MELBOURNE
 BSB: 013 128
 ACCOUNT NO: 837 249 625
 PLEASE QUOTE YOUR CUSTOMER NO. AS THE REFERENCE AND
 EMAIL YOUR REMITTANCE ADVICE TO: CREDIT@WADAMS.COM.AU

THANK YOU FOR CHOOSING WILLIAM ADAMS
 HELP US IMPROVE VIA FEEDBACK@WADAMS.COM.AU
 BANKING DETAILS: ANZ BANK - MELBOURNE
 BSB: 013 128
 ACCOUNT NO: 8372 49625
 REFERENCE: YOUR CUSTOMER NUMBER
 EMAIL YOUR REMITTANCE ADVICE TO: CREDITMILDURA@WADAMS.COM.AU
 * * * INVOICE COPY * * *



Please consider recycling this invoice to support our commitment to sustainability. Switch to digital invoicing for a greener option.

E. & O.E.

ITEMS ORDERED NOT SHOWN ARE BACK ORDERED

+ NOT RETURNABLE

TERMS :
EQUIPMENT/RENTAL SALES-CASH EX WORKS
PARTS/SERVICE SALES - STRICTLY NETT 30 DAYS

BANKING DETAILS : ANZ BANK MELBOURNE
BSB : 013 128
ACCOUNT NO : 837 249 625
REFERENCE : 306150
EMAIL YOUR REMITTANCE ADVICE TO :
CreditRegional@wadams.com.au

PAY THIS AMOUNT
Incl GST AUD 4782.02

AMOUNT CREDITED
Incl GST

WA24

William Adams Pty Ltd's Standard Conditions of Quotation and Sale apply to this transaction.
They can be obtained at www.williamadams.com.au/termsandconditions or by calling (03) 9566 0666
Thank You for choosing William Adams. Help us improve via FEEDBACK@WADAMS.COM.AU

William Adams



TAX INVOICE

William Adams Pty. Ltd A.B.N. 72 009 569 493 A.C.N. 009 569 493

HEAD OFFICE
17 - 55 Nantilla Road,
Clayton Vic 3168
Tel: (03) 9566 0666

P.O. Box 164,
Clayton Vic 3168
Fax: (03) 9561 6273

VICTORIAN BRANCHES
Bendigo: (03) 5434 2100
Dandenong: (03) 9767 3666
Geelong: (03) 5223 5223
Horsham: (03) 5362 4100
Laverton: (03) 9931 9666

Mildura: (03) 5018 6100
Portland: (03) 5521 5110
Swan Hill: (03) 5036 3900
Traralgon: (03) 5175 6200
Wodonga: (02) 6051 5800

TASMANIAN BRANCHES
Hobart: (03) 6249 0566
Launceston: (03) 6325 0900
Burnie: (03) 6433 8888

SOLD TO:

SHIP TO:

**GARRAWAY EARTHMOVING PTY LTD TRADING AS
GARRAWAY GROUP
PO BOX 3378
MILDURA VIC 3502**

INVOICE No.	INVOICE DATE	CUSTOMER No.	CUSTOMER ORDER No.	STORE	DIV	SALESPERSON	T.C.	PAGE
S2SR0060828	12-01-24	306150	SC09	00	G		2	1
DOCUMENT No.	DOCUMENT DATE	PC	LC	MC	SHIP VIA			A.B.N.
0W97187	02-01-24	10	1C	10				54 098 851 631
MAKE	MODEL	SERIAL NUMBER		EQUIPMENT NUMBER	METER READING		MACH. ID No.	
AA	627G	0DBD00838		SC09				
QUANTITY	ITEM	NR	DESCRIPTION		UNIT PRICE	EXTENSION		

BAD CODE PLEASE USE 890 CLUTCH HOUSING

- DRILL AND SLEEVE REACTION DOWEL HOLES.
- 24X DOWEL HOLES ACROSS 5 HOUSINGS.

F/R LBR
F/R MSC

5740.00 *
135.00 *
5875.00 T

SEGMENT 10 TOTAL

ENVIR/CONSUM CHG

287.00 T

Subtotal before taxes
G.S.T.

6162.00
616.20 T

WILLIAM ADAMS PTY LTD REFRIGERANT TRADING AUTHORISATION NUMBER AU04614
* * * INVOICE COPY * * *



Please consider recycling this invoice to support our commitment to sustainability. Switch to digital invoicing for a greener option.

E. & O.E.

ITEMS ORDERED NOT SHOWN ARE BACK ORDERED

+ NOT RETURNABLE

TERMS :
EQUIPMENT/RENTAL SALES-CASH EX WORKS
PARTS/SERVICE SALES - STRICTLY NETT 30 DAYS

BANKING DETAILS : ANZ BANK MELBOURNE
BSB : 013 128
ACCOUNT NO : 837 249 625
REFERENCE : 306150
EMAIL YOUR REMITTANCE ADVICE TO :
CreditClayton@wadams.com.au

PAY THIS AMOUNT
Incl GST AUD 6778.20

AMOUNT CREDITED
Incl GST

WA24

William Adams Pty Ltd's Standard Conditions of Quotation and Sale apply to this transaction.
They can be obtained at www.williamadams.com.au/termsandconditions or by calling (03) 9566 0666
Thank You for choosing William Adams. Help us improve via FEEDBACK@WADAMS.COM.AU

Component Change-Out & Major Component History - Invoices

Date	Component	Part Number / Description
7-Mar-18	Fuel Injector	387-9433
25-Jun-20	Replace Rear Engine	
29-Mar-22	Torque Convertor	198-2806
23-Jun-22	Power Train Cooler	10R-3667
	Transmission rebuild \Speed	
19-Dec-23	Sensor	338-1462
2-Jan-24	Transmission Pump	0R-4783
30-Jan-24	Oil Cooler Core Group	0R-3366 CORE GP – OIL CLR
13-Feb-24	Flywheel Assembly	7N-9650
16-Jul-24	Rear Differential	CAT 627 Apron Rear Diff 208-2977

Action	Source	Reference
Replaced	William Adams	Invoice PR000708196 Invoice SR140010344
Replaced	William Adams	Invoice P2PR0119866
Replaced	William Adams	Invoices P2PR0155397
Replaced	William Adams	Invoice P2PR0364962, Invoice P2PR0367628 & P2PR0367947
Replaced	William Adams	Invoice P2PR0367401
Replaced	William Adams	Invoice P2PR0376483
Replaced	William Adams	Invoice P2PR0382204
Replaced (2nd hand)	Charles Hull Contracting	Invoice 651927

Notes	Cost
Parts supply record	\$1,228.40
Completed by William Adams	\$62,830.00
Parts supply record	\$16,500
Parts supply record	\$4,578.93
Parts supply record	\$39,739.87
Parts supply record	\$3,028.73
Includes gasket and core deposit	\$7,819.20
Parts supply record	\$4,006.23
Supplied as-is, where-is	\$8,000

MAJOR REPAIRS & COMPONENT CHANGE-OUTS (GROUPED)

REMOVE & INSTALL ENGINE – REAR

Rear engine was removed and reinstalled in conjunction with a **Caterpillar Certified Machine Component Rebuild (E**

Scope of Work – Engine Package

Replaced air filters and air restriction gauge

Replaced engine-to-radiator hoses and clamps

Replaced charge air (turbo) hoses and clamps

Inspected and flushed radiator assembly

Replaced engine coolant

Replaced engine mounts

Additional Customer Installation Items

Installed new electrical wiring harness

Installed engine drive belts and tensioners

Installed fan spider assembly

Commissioning & Testing

Completed full machine commissioning

Performed engine performance testing

Engine and associated systems tested **serviceable**

Exhaust Manifold Major Repair – Rear & Front Engine

Late July – Early August 2024

Primary repair

Exhaust manifold reseal (front & rear engines)

Associated work

Rocker cover reseal

Multiple follow-up exhaust reseals

Engine light investigation

Final reassembly & completion

Why this is a major repair

Multi-day work

Repeated reseals

Direct engine integrity issue

Powertrain / Transmission Line Failure & Recovery

Mid-Late September 2024

Primary repair

Powertrain / transmission line failure in pit

Machine recovery from pit

Associated work

Breakdown in pit

Damaged guard and transmission lines

Temporary hoses fitted

Multiple recoveries from pit

Removal and replacement of powertrain hoses

Isolation, tyre removal, guarding repairs

Why this is a major repair

Unplanned breakdown

Recovery operations

Powertrain oil containment & line replacement

Transmission & Powertrain Pipework Rebuild

Late September – Early October 2024

Primary repair

Removal and replacement of broken transmission lines

Installation of new transmission piping

Associated work

Remove tyres

Straighten / repair guard brackets

Order and collect parts

Reassemble machine

Fit inner guards

Brake defect check post-repair

Why this is a major repair

Significant disassembly

Multiple system interactions (brakes, guards, tyres)

Muffler & Air Intake System Replacement

Early–Mid October 2024

Primary repair

Muffler replacement

Pre-cleaner replacement

Associated work

Remove muffler & pre-cleaner

Run-up testing

POS guard straightening

Engine throttle / trans hose repairs shortly after

Why this is a major repair

Engine exhaust & intake system intervention

Testing required post-install

Steering & Bowl Trunnion Major Mechanical Work

Late October 2024

Primary repair

Bowl trunnions & caps replacement

RHS steering cylinder replacement

Associated work

Drill out broken belly plate bolts

Re-threading

Seat repairs during downtime

Side arm trunnions replacement

Belly guard installation

Steering pin refit

Why this is a major repair

Structural / articulation components

Precision torque & alignment work

Diff Lock System Fault & Pneumatic Repairs

Nov–Dec 2024

Primary repair

Diff lock faults

Associated work

Air leaks

Solenoid & switch checks

Rear engine overheating checks

Radiator washouts

Repeat inspections & testing

Why this is a major repair

Repeated fault diagnosis

Air + driveline interaction

Apron Pivot, Pins & Structural Repairs

Jan–Feb 2025

Primary repair

Apron pin and pivot replacement

Apron arm pin replacement

Associated work

Apron crack repairs

Apron defect inspections

Welding / fabrication

Washdowns and return-to-work testing

Why this is a major repair

Load-bearing components

Structural cracking

Electrical / GPS Ongoing Fault Campaign

Multiple periods – 2024 to 2025

Primary repairs

GPS failures

Product link / data link faults

Electrical faults

Associated work

Screen swaps between machines

Harness repairs

Power supply troubleshooting

VisionLink faults

Repeat diagnostics

Why this is a major repair

Recurring reliability issue

Multiple subsystems involved

Final Drive & Wheel End Rebuild (POS 4)

Mid August 2025

Primary repair

Duo-cone seal failure – final drive

Associated work

Remove tyre

Strip wheel end

Clean components

Replace seals

Reassemble, fill oil, test

Final inspection

Why this is a major repair

Final drive intrusion

Seal failure with oil contamination risk

Rear Engine Belts, Tensioner & Transmission Oil Leak

Oct-25

Primary repair

Rear engine belt & tensioner replacement

Front transmission oil leak repair

Associated work

Belly plate removal

Oil leak inspections

Cooler/retarder line replacement

Guard and fabrication work

Why this is a major repair

Engine drive components

Oil system integrity

Hour Meter Reading

13600

17350

17410

17450

17450

17500

17700

17850

18500

Parts

PLANT & MOTOR VEHICLE EXP

Plant & Equipment Expenses

Repairs & Maintenance

Scrapers

SC09

Total SC09

Total Scrapers

Total Repairs & Maintenance

Tyres & Tubes

Scrapers

SC09

Total SC09

Total Scrapers

Total Tyres & Tubes

<u>Type</u>	<u>Date</u>	<u>Num</u>	<u>Description</u>	<u>Source Name</u>
Bill	15/04/2010	934	Repairs & Maintenance - SC MTP Pty Ltd	
Bill	26/05/2010	2100	Repairs & Maintenance - SC Robin Johns C	
Bill	28/05/2010	PR140035141	Repairs & Maintenance - SC William Adam:	
Bill	28/05/2010	PR140035142	Repairs & Maintenance - SC William Adam:	
Bill	28/05/2010	PR140035174	Repairs & Maintenance - SC William Adam:	
Bill	28/05/2010	PR140035164	Repairs & Maintenance - SC William Adam:	
Bill	28/05/2010	PR140035165	Repairs & Maintenance - SC William Adam:	
Bill	31/05/2010	PR140035202	Repairs & Maintenance - SC William Adam:	
Bill	31/05/2010	PR140035203	Repairs & Maintenance - SC William Adam:	
Credit	01/06/2010		Repairs & Maintenance - SC David Carson	
Bill	03/06/2010	PR140035265	Repairs & Maintenance - SC William Adam:	
Bill	04/06/2010	PR140035282	Repairs & Maintenance - SC William Adam:	
Bill	04/06/2010	PR140035281	Repairs & Maintenance - SC William Adam:	
Bill	04/06/2010	PR140035288	Repairs & Maintenance - SC William Adam:	
Bill	04/06/2010	36237	Repairs & Maintenance - SC Sunraysia Aut	
Bill	09/06/2010	PR000442614	Repairs & Maintenance - SC William Adam:	
Bill	09/06/2010	PR000442615	Repairs & Maintenance - SC William Adam:	
Bill	10/06/2010	PR140035365	Repairs & Maintenance - SC William Adam:	
Bill	10/06/2010	PR140035364	Repairs & Maintenance - SC William Adam:	
Bill	10/06/2010	PR140035363	Repairs & Maintenance - SC William Adam:	
Bill	10/06/2010	PR140035390	Repairs & Maintenance - SC William Adam:	
Bill	10/06/2010	PR140035383	Repairs & Maintenance - SC William Adam:	
Bill	16/06/2010	PR140035646	Repairs & Maintenance - SC William Adam:	
Bill	16/06/2010	PR140035465	Repairs & Maintenance - SC William Adam:	
Bill	18/06/2010	PR140035517	Repairs & Maintenance - SC William Adam:	
Bill	18/06/2010	PR140035518	Repairs & Maintenance - SC William Adam:	
Bill	18/06/2010	PR140035519	Repairs & Maintenance - SC William Adam:	
Bill	21/06/2010	35360	Repairs & Maintenance - SC David Carson	
Bill	21/06/2010	36483	Repairs & Maintenance - SC Sunraysia Aut	
Bill	21/06/2010	36470	Repairs & Maintenance - SC Sunraysia Aut	
Credit Card Charge	22/06/2010	2010419382	Repairs & Maintenance - SC Repco Mildura	
Bill	22/06/2010	7178	Repairs & Maintenance - SC Robin Johns C	
Bill	22/06/2010	17595	Repairs & Maintenance - SC TBAS Precisic	
Bill	22/06/2010	PR140035581	Repairs & Maintenance - SC William Adam:	
Bill	22/06/2010	PR140035560	Repairs & Maintenance - SC William Adam:	
Bill	22/06/2010	PR140035565	Repairs & Maintenance - SC William Adam:	
Credit Card Charge	23/06/2010	149277	Repairs & Maintenance - SC Clark Rubber I	
Bill	23/06/2010	8814491	Repairs & Maintenance - SC Coventry Fast	
Bill	23/06/2010	36506	Repairs & Maintenance - SC Sunraysia Aut	
Bill	24/06/2010	PR140035614	Repairs & Maintenance - SC William Adam:	
Bill	24/06/2010	PR140035630	Repairs & Maintenance - SC William Adam:	
Bill	24/06/2010	PR140035631	Repairs & Maintenance - SC William Adam:	
Bill	25/06/2010	PR140035672	Repairs & Maintenance - SC William Adam:	
Bill	25/06/2010	9514	Repairs & Maintenance - SC APK Engineer	
Bill	30/06/2010	PR140035709	Repairs & Maintenance - SC William Adam:	
Bill	30/06/2010	PR140035694	Repairs & Maintenance - SC William Adam:	
Bill	30/06/2010	PR140035695	Repairs & Maintenance - SC William Adam:	
Bill	30/06/2010	PR140035696	Repairs & Maintenance - SC William Adam:	

Bill	30/06/2010	PR140035697	Repairs & Maintenance - SC William Adam:
Bill	08/07/2010	36968	Repairs & Maintenance - SC Sunraysia Aut
Bill	22/07/2010	9553	Repairs & Maintenance - SC APK Engineer
Bill	04/08/2010	434	Repairs & Maintenance - SC Sunstone Indu
Bill	04/08/2010	433	Repairs & Maintenance - SC Sunstone Indu
Bill	13/08/2010	450	Repairs & Maintenance - SC Sunstone Indu
Bill	19/08/2010	PR000449584	Repairs & Maintenance - SC William Adam:
Bill	06/09/2010	1236145	Repairs & Maintenance - SC Mildura Truck
Bill	30/06/2011	PR140041590	Repairs & Maintenance - SC William Adam:
Bill	05/07/2011	19599	Repairs & Maintenance - SC TBAS Precisic
Bill	15/07/2011	PR140041797	Repairs & Maintenance - SC William Adam:
Bill	19/07/2011	19680	Repairs & Maintenance - SC TBAS Precisic
Bill	20/07/2011	PR000483494	Repairs & Maintenance - SC William Adam:
Bill	21/07/2011	PR140041954	Repairs & Maintenance - SC William Adam:
Bill	25/07/2011	2440	Repairs & Maintenance - SC Sunraysia Har
Bill	28/07/2011	PR140042096	Repairs & Maintenance - SC William Adam:
Bill	28/07/2011	41736	Repairs & Maintenance - SC Sunraysia Aut
Bill	30/07/2011	13333	Repairs & Maintenance - SC BA & LJ Bottre
Bill	27/08/2011	PR140042673	Repairs & Maintenance - SC William Adam:
Bill	30/08/2011	PR140042691	Repairs & Maintenance - SC William Adam:
Bill	01/09/2011	PR000487957	Repairs & Maintenance - SC William Adam:
Bill	01/09/2011	PR000487958	Repairs & Maintenance - SC William Adam:
Bill	02/09/2011	PR140042769	Repairs & Maintenance - SC William Adam:
Bill	03/09/2011	PR140042797	Repairs & Maintenance - SC William Adam:
Bill	20/09/2011	1256589	Repairs & Maintenance - SC Mildura Truck
Bill	01/10/2011	00015097	Repairs & Maintenance - SC Bottrell Mecha
Bill	09/10/2011	00015088	Repairs & Maintenance - SC Bottrell Mecha
Bill	20/10/2011	PR140043703	Repairs & Maintenance - SC William Adam:
Bill	22/11/2011	PR140044358	Repairs & Maintenance - SC William Adam:
Bill	06/01/2012	PR140045184	Repairs & Maintenance - SC William Adam:
Bill	06/01/2012	PR140045185	Repairs & Maintenance - SC William Adam:
Bill	06/01/2012	PR140045186	Repairs & Maintenance - SC William Adam:
Bill	09/01/2012	PR140045244	Repairs & Maintenance - SC William Adam:
Bill	17/01/2012	PR140045362	Repairs & Maintenance - SC William Adam:
Bill	17/01/2012	PR140045363	Repairs & Maintenance - SC William Adam:
Bill	17/01/2012	PR140045364	Repairs & Maintenance - SC William Adam:
Bill	17/01/2012	PR140045365	Repairs & Maintenance - SC William Adam:
Bill	17/01/2012	PR140045366	Repairs & Maintenance - SC William Adam:
Bill	17/01/2012	PR140045367	Repairs & Maintenance - SC William Adam:
Bill	20/01/2012	PR140045396	Repairs & Maintenance - SC William Adam:
Bill	23/01/2012	PR140045433	Repairs & Maintenance - SC William Adam:
Bill	06/02/2012	PR140045858	Repairs & Maintenance - SC William Adam:
Bill	11/08/2012	PR000523489	0R-8381 Shoe As Brake William Adam:
Bill	11/08/2012	PR000523489	0R-8381 Core Deposit William Adam:
Bill	11/08/2012	PR000523489	8H-8257 Seal O Ring William Adam:
Bill	11/08/2012	PR000523489	9G-5319 Seal G William Adam:
Bill	11/08/2012	PR000523489	8D-4004 Spring William Adam:
Bill	11/08/2012	PR000523490	5T-0975 Camshaft William Adam:
Bill	11/08/2012	PR000523490	0R-8381 SHOE ASSEMBLY William Adam:
Bill	11/08/2012	PR000523490	0R-8381 CORE DEPOSIT William Adam:
Bill	11/08/2012	PR000523494	6K-9149 SEAL O RING William Adam:
Bill	15/08/2012	PR140049315	4J-8665 BIT William Adam:
Bill	04/09/2012	15549	0320-8-8 Male JIC 37 Flare Enzed Service
Bill	04/09/2012	15549	20020-8 Hose S cket 20 Ser Enzed Service
Bill	04/09/2012	15549	206-8-RL SAE 10 R5 Hose F Enzed Service
Bill	06/09/2012	ST140005559	6K-2643 BOOT William Adam:

Bill	06/09/2012	ST140005559	187-0424 ACTUATOR BOO`	William Adam:
Bill	06/09/2012	ST140005559	LABOUR RESEAL BRAKE /	William Adam:
Bill	06/09/2012	ST140005559	ENVIRONMENTAL/CONSUM	William Adam:
Bill	13/09/2012	PR000527105	3G-0954 BEARING A	William Adam:
Bill	13/09/2012	PR000527105	5L-4776 SEAL	William Adam:
Bill	13/09/2012	PR000527105	3G-7482 SLEEVE	William Adam:
Bill	13/09/2012	PR000527105	9B-7237 SCREW	William Adam:
Bill	13/09/2012	PR000527105	8T-4896 WASHER	William Adam:
Bill	13/09/2012	PR000527105	8J-9810 GASKET	William Adam:
Bill	13/09/2012	PR000527105	7H-7539 NUT	William Adam:
Bill	13/09/2012	PR000527105	5P-8249 WASHER-HARD	William Adam:
Bill	13/09/2012	PR000527106	3G-0954 BEARING	William Adam:
Bill	14/09/2012	PR000527248	1T-0433 CUP	William Adam:
Bill	14/09/2012	PR000527248	1T-0434 CONE	William Adam:
Bill	20/09/2012	PR000527889	6N-7653 GAGE A OIL	William Adam:
Bill	24/09/2012	SR14005610	Disassemble & Assemble Br	William Adam:
Credit	01/10/2012	CR000050716	0R-4381 Core Return	William Adam:
Bill	04/10/2012	PR000529396	3E-2030 Switch GP	William Adam:
Bill	04/10/2012	PR000529396	4N-3841 Gasket	William Adam:
Bill	09/10/2012	PR000529909	3S-9643 Seal-Lip Type Wat	William Adam:
Bill	09/10/2012	PR000529909	7C-0307 Gasket	William Adam:
Bill	09/10/2012	PR000529909	4N-1156 Gasket Regulator	William Adam:
Bill	09/10/2012	PR000529909	109-0076 Seal O Ring	William Adam:
Bill	09/10/2012	PR000529910	248-5513 Regulator	William Adam:
Bill	12/10/2012	PR000530398	10R-0482 Pump GP WTR	William Adam:
Bill	12/10/2012	PR000530398	10R-0482 Core Deposit	William Adam:
Bill	12/10/2012	PR000530398	4P-2383 Adapter	William Adam:
Bill	12/10/2012	PR000530398	9M-3786 Seal O Ring	William Adam:
Bill	12/10/2012	PR000530398	7C-0307 Gasket	William Adam:
Bill	12/10/2012	PR000530398	109-0076 Seal O Ring	William Adam:
Bill	18/10/2012	SR140005656	Repairs to Hitch Lift Cylinder	William Adam:
Bill	09/11/2012	PR000533192	137-4367 Base	William Adam:
Credit	20/11/2012	CR140006836	10R-0482 CORE RETURN	William Adam:
Bill	21/11/2012	PR000534380	305-6293 COUPLING AS	William Adam:
Bill	21/11/2012	PR000534380	1P-3705 SEAL	William Adam:
Bill	21/11/2012	PR000534380	1P-3704 SEAL	William Adam:
Bill	21/11/2012	PR000534380	161-1837 HOSE xt6	William Adam:
Bill	21/11/2012	PR000534380	HOSE ASSEMBLY LABOUF	William Adam:
Bill	21/11/2012	PR000534381	337-3388 COUPLING AS	William Adam:
Bill	27/11/2012	PR000535007	3E-1906 Comp G BSC	William Adam:
Bill	27/11/2012	PR000535007	3E-3535 Dryer	William Adam:
Bill	28/11/2012	PR000535150	2D-2444 Seal	William Adam:
Bill	30/11/2012	PR000535534	7J-9108 Seal	William Adam:
Bill	30/11/2012	PR000535534	9X-2375 In Hose STC	William Adam:
Bill	30/11/2012	PR000535534	9X-3883 Coupling	William Adam:
Bill	30/11/2012	PR000535534	7J-9108 Seal	William Adam:
Bill	30/11/2012	PR000535534	Labour Hose Assy	William Adam:
Bill	30/11/2012	PR000535536	9X-3887 Coupling	William Adam:
Bill	30/11/2012	PR000535536	6V-8397 Seal	William Adam:
Bill	30/11/2012	PR000535536	9X-2373 In Hose Stock	William Adam:
Bill	30/11/2012	PR000535536	7X-1463 Coupling	William Adam:
Bill	30/11/2012	PR000535536	6V-8397 SEal	William Adam:
Bill	30/11/2012	PR000535536	Labour Hose Assembly	William Adam:
Bill	30/11/2012	PR000535535	9X-3889 Coupling	William Adam:
Bill	06/12/2012	PR000536071	1T-0433 cup	William Adam:
Bill	06/12/2012	PR000536071	1T-0434 Cone	William Adam:

Bill	07/03/2013	PR000544910	3E-5464 Switch A	William Adam:
Bill	07/03/2013	PR000544910	2G-0401 Valve	William Adam:
Bill	07/03/2013	PR000544910	6M-5062 Seal O Ring	William Adam:
Bill	02/05/2013	PR140053879	8J-6552 Carrier	William Adam:
Bill	16/05/2013	PR000551223	9N-3666 Valve A	William Adam:
Bill	16/05/2013	PR000551223	9X-2488 Clamp	William Adam:
Bill	16/05/2013	PR000551223	9B-7237 Screw	William Adam:
Bill	16/05/2013	PR000551223	7X-0772 Washer	William Adam:
Bill	23/05/2013	PR000551935	3E-6256 Coil AS-Heat	William Adam:
Bill	20/06/2013	PR31000092	324-0843 Harness AS	William Adam:
Bill	20/06/2013	PR31000092	338-1462 Sensor GP-PO	William Adam:
Bill	27/06/2013	PR140055044	3G-3393 Link A	William Adam:
Bill	27/06/2013	PR140055043	3G-3393 Link A	William Adam:
Bill	27/06/2013	PR140055043	8J-7675 Link A	William Adam:
Bill	27/06/2013	PR140055042	0S-1756 Cap Screw	William Adam:
Bill	27/06/2013	PR140055042	316-4419 Sprocket	William Adam:
Bill	27/06/2013	PR140055041	2J-3506 Nut	William Adam:
Bill	27/06/2013	PR140055041	5P-8248 Washer	William Adam:
Bill	02/07/2013	PR000555260	5M-7329 Sral O Ring	William Adam:
Bill	02/07/2013	PR000555260	5P-6420 Bearing A	William Adam:
Bill	02/07/2013	PR000555260	6L-8535 Bolt	William Adam:
Bill	02/07/2013	PR000555260	045-5106 Pin	William Adam:
Bill	02/07/2013	PR000555260	2T-3249 Shim Pack	William Adam:
Bill	02/07/2013	PR000555260	1S-9110 Bearing A	William Adam:
Bill	02/07/2013	PR000555260	2T-3062 Disc Spacer	William Adam:
Bill	02/07/2013	PR000555260	5M-6126 Bearing A	William Adam:
Bill	02/07/2013	PR000555260	5M-2894 Easher-Hard 10.2x	William Adam:
Bill	02/07/2013	PR000555260	3F-1395 Seal	William Adam:
Bill	02/07/2013	PR000555260	3S-2331 Race A	William Adam:
Bill	02/07/2013	PR000555260	5S-6502 Race	William Adam:
Bill	02/07/2013	PR000555260	3D-2824 Seal O Ring	William Adam:
Bill	02/07/2013	PR000555260	6L-8535 Bolt	William Adam:
Bill	02/07/2013	PR000555260	5H-3182 Pin	William Adam:
Bill	03/07/2013	PR000555372	045-5106 Pin	William Adam:
Bill	03/07/2013	PR000555372	2T-3036 Disc Spacer	William Adam:
Bill	03/07/2013	PR000555372	045-5106 Pin	William Adam:
Bill	03/07/2013	PR000555372	8I-1697 Retainer Plate	William Adam:
Bill	03/07/2013	PR000555372	7G-9375 Shaft	William Adam:
Bill	03/07/2013	PR000555372	7G-9374 Shaft	William Adam:
Bill	03/07/2013	PR000555373	5N-7639 Seal G	William Adam:
Bill	10/07/2013	PR000556013	5H-3193 Pin	William Adam:
Bill	10/07/2013	PR000556014	6T-2965 Gear	William Adam:
Bill	13/07/2013	6124	Repair seal areas on scrape	Mallee Machin
Bill	07/08/2013	PR000558559	5M-7329 Seal O Ring	William Adam:
Bill	07/08/2013	PR000558559	045-5106 Pin	William Adam:
Bill	07/08/2013	PR000558559	7G-6201 Washer	William Adam:
Bill	07/08/2013	PR000558559	5N-7639 Seal G	William Adam:
Bill	07/08/2013	PR000558559	5H-3182 Pin	William Adam:
Bill	07/08/2013	PR000558559	9F-6656 Ring	William Adam:
Bill	07/08/2013	PR000558559	3F-1395 Seal	William Adam:
Bill	07/08/2013	PR000558559	5H-3193 Pin	William Adam:
Bill	07/08/2013	PR000558559	3D-2824 Seal O Ring	William Adam:
Bill	07/08/2013	PR000558560	8I-2383 Washer-Speci	William Adam:
Bill	07/08/2013	PR000558560	7X-3326 Bolt	William Adam:
Bill	23/08/2013	PR000559977	3E-0462 Control G	William Adam:
Bill	23/08/2013	PR000559977	103-6168 Bearing AS	William Adam:

Bill	23/08/2013	PR000559976	7X-1560 Seal	William Adam:
Bill	27/08/2013	PR000560258	6V-9973 Coupling A	William Adam:
Bill	27/08/2013	PR000560258	5K-9090 Seal O Ring	William Adam:
Bill	27/08/2013	PR000560258	165-0021 XT3 ES Hose	William Adam:
Bill	27/08/2013	PR000560257	6T-6970 Switch A	William Adam:
Bill	27/08/2013	PR000560256	3E-8793 Autuator	William Adam:
Bill	27/08/2013	PR000560256	2K-8257 Seal	William Adam:
Bill	16/10/2013	SR140006399	Install Rebuild Tag to Both A	William Adam:
Bill	16/10/2013	SR140006399	4C-4200 Paint-Yellow	William Adam:
Bill	16/10/2013	SR140006399	6K-1807 Diaphragm	William Adam:
Bill	16/10/2013	SR140006399	6K-2643 Boot	William Adam:
Bill	16/10/2013	SR140006399	187-0424 Actuator KT	William Adam:
Bill	16/10/2013	SR140006399	5WA1978 ID Plate for Comp	William Adam:
Bill	16/10/2013	SR140006399	Brake Cleaner	William Adam:
Bill	16/10/2013	SR140006399	Envir/Consum CHG	William Adam:
Bill	18/10/2013	PR000565073	6G-0078 Breather	William Adam:
Bill	21/10/2013	PR000565200	8X-9126 FLOOR MAT	William Adam:
Bill	31/10/2013	PR000566235	7I-5485 Hose AS	William Adam:
Bill	31/10/2013	PR000566235	7I-5414 Hose AS	William Adam:
Bill	15/11/2013	PR000567471	103-0010 Bracket A	William Adam:
Bill	15/11/2013	PR000567471	8T-9782 Switca A	William Adam:
Bill	15/11/2013	PR000567470	276-7018 Kit Cap Plug	William Adam:
Bill	15/11/2013	PR000567470	8T-4896 Washer	William Adam:
Bill	15/11/2013	PR000567470	3K-6060 Nut	William Adam:
Bill	25/02/2014	127794	T224-0814 JIC Female 90Df	Sunrise AG
Bill	25/02/2014	127794	1/2 Hyd Hose 1/2 Inch doubl	Sunrise AG
Bill	25/02/2014	127794	Workshop Labour Charge	Sunrise AG
Bill	26/02/2014	PR000575521	6V-8398 Seal O Ring	William Adam:
Bill	26/02/2014	PR000575521	8W-3107 Hose A	William Adam:
Bill	26/02/2014	PR000575522	5K-5338 Clip Large	William Adam:
Bill	26/02/2014	PR000575522	8J-8197 Clip	William Adam:
Bill	03/07/2014	PR000586342	8N-9394 Hose A	William Adam:
Bill	07/07/2014	PR140064431	434-1918 Roller-CLA	William Adam:
Bill	09/07/2014	PR140064522	136-7683 Hose AS	William Adam:
Bill	23/07/2014	PR000587911	6V-8188 Nut	William Adam:
Bill	23/07/2014	PR000587911	1J-4947 Bolt	William Adam:
Bill	23/07/2014	PR000587911	2J-3507 Nut	William Adam:
Bill	23/07/2014	PR000587911	1U-3302 Tip	William Adam:
Bill	23/07/2014	PR000587911	8E-6259 Retainer G	William Adam:
Bill	23/07/2014	PR000587911	107-3308 Pin GET	William Adam:
Bill	25/07/2014	PR000588120	1V-0134 Pin	William Adam:
Bill	25/07/2014	PR000588120	4V-1074 Plate	William Adam:
Bill	25/07/2014	PR000588120	140-3673 Handle AS	William Adam:
Bill	25/07/2014	PR000588120	398-8345 Pin-Cla	William Adam:
Bill	16/12/2014	PR000600139	6V-3256 Rod-End	William Adam:
Bill	16/12/2014	PR000600139	174-7875 Horn AS - 24	William Adam:
Bill	11/02/2015	PR000604468	3Y-2888 Adapter-Str	William Adam:
Bill	11/02/2015	PR000604468	3J-1907 Seal	William Adam:
Bill	11/02/2015	PR000604467	8W-4302 Hose A	William Adam:
Bill	11/02/2015	PR000604467	8W-3102 Hose A	William Adam:
Bill	11/02/2015	PR000604467	105-2508 Pump AS	William Adam:
Bill	11/02/2015	PR000604467	1P-0436 Gasket	William Adam:
Bill	11/02/2015	PR000604467	7E-2464 Valve AS	William Adam:
Bill	11/02/2015	PR000604467	7J-9108 Seal	William Adam:
Bill	12/02/2015	PR000604595	3Y-2888 Sadapter-STR	William Adam:
Bill	30/04/2015	PR140071720	3T-5760 Battery	William Adam:

Bill	30/04/2015	PR000611909	4D-6475 Union	William Adam:
Bill	30/04/2015	PR000611909	3G-7875 Hose A	William Adam:
Bill	30/04/2015	PR000611909	3G-0575 Hose A	William Adam:
Bill	30/04/2015	PR000611909	6B-9664 Valve	William Adam:
Bill	30/04/2015	PR000611910	272-6628 Lock As-Cylinder	William Adam:
Bill	05/08/2015	PR140074303	5P-6879 Mirror	William Adam:
Bill	29/09/2015	PR140075719	5J - 4988 *Seal A	William Adam:
Bill	29/09/2015	PR140075719	8J - 0201 Bearing	William Adam:
Bill	29/09/2015	PR140075719	2K - 2961 *Ring	William Adam:
Bill	29/09/2015	PR140075719	4J - 4606 *Ring	William Adam:
Bill	29/09/2015	PR140075719	8T - 5668 *Ring Wear	William Adam:
Bill	29/09/2015	PR140075718	5P - 9962 Bearing	William Adam:
Bill	29/09/2015	PR140075718	365 - 1382 *Kit - Seal - H.C	William Adam:
Bill	29/09/2015	PR140075718	6V - 8179 *Ring	William Adam:
Bill	29/09/2015	PR140075718	6V - 8347 *Seal	William Adam:
Bill	29/09/2015	PR140075718	289 - 2937 *Seal AS	William Adam:
Bill	29/09/2015	PR140075718	289 - 2948 *Seal U	William Adam:
Bill	29/09/2015	PR140075718	225 - 3281 *Seal - Wiper	William Adam:
Bill	29/09/2015	PR140075718	2H - 9247 *Ring	William Adam:
Bill	29/09/2015	PR140075720	5L - 4776 *Seal	William Adam:
Bill	29/09/2015	PR140075722	8D - 7057 Valve A	William Adam:
Bill	29/09/2015	PR140075721	3S - 7023 Washer	William Adam:
Bill	29/09/2015	PR140075721	7H - 7539 Nut	William Adam:
Bill	29/09/2015	PR140075721	3S - 7023 Washer	William Adam:
Bill	29/09/2015	PR140075721	030 - 0058 Bearing A	William Adam:
Bill	29/09/2015	PR140075721	8J - 6552 Carrier	William Adam:
Bill	29/09/2015	PR140075721	4H - 2400 Bolt	William Adam:
Bill	30/09/2015	3136564	5T-8528 Pin-Hitch (5T3016)	Cutting Edges
Bill	30/09/2015	3136564	9J-1676 Bearing - Hitch 621I	Cutting Edges
Bill	30/09/2015	3136564	5T-8526 Pin-Hitch-631B	Cutting Edges
Bill	30/09/2015	3136564	7J-3663 Washer-Nitch(Bron:	Cutting Edges
Bill	30/09/2015	3136564	8J-0632 Pin-Hitch-621B	Cutting Edges
Bill	30/09/2015	3136564	7J-8458 Bearing-Hitch Brass	Cutting Edges
Bill	30/09/2015	3136564	4h-2636 Ring	Cutting Edges
Bill	30/09/2015	3136564	4J-5693 Bearing-Hiitch-627E	Cutting Edges
Bill	30/09/2015	3136564	4J-5695 Bearing-Hitch-627B	Cutting Edges
Bill	30/09/2015	3136564	9J-1676 Bearing-Hitch 621B	Cutting Edges
Bill	30/09/2015	3136564	9J-1679 Bush-Hitch-627B	Cutting Edges
Bill	30/09/2015	3136564	1K-6870 Self Locking Nut 34	Cutting Edges
Bill	30/09/2015	3136564	4J-5689 Washer-621B	Cutting Edges
Bill	30/09/2015	3136564	8J-7596 Bearing-Hitch-621B	Cutting Edges
Bill	30/09/2015	3136564	9J-9427 Bearing Steel (STD)	Cutting Edges
Bill	30/09/2015	3136564	5J-6611 Bearing-Hitch 631B	Cutting Edges
Bill	30/09/2015	3136564	4J-5694 Bearing-Hitch 627B,	Cutting Edges
Bill	30/09/2015	3136564	8J-7727 Pin-Hitch-621B	Cutting Edges
Bill	30/09/2015	3136564	6G-5155 Bearing-627B	Cutting Edges
Bill	30/09/2015	3136564	4J-5690 Spacer-621B	Cutting Edges
Bill	30/09/2015	3136564	4J-5692 Washer-Hitch-621B	Cutting Edges
Bill	30/09/2015	3136564	5T-3323 Pin-Hitch	Cutting Edges
Bill	01/10/2015	3136711	3B4627 Pin, Cotter	Cutting Edges
Bill	01/10/2015	3136711	1021444 Bush	Cutting Edges
Bill	01/10/2015	3136711	1483465 Pin, Hitch - 623E/6	Cutting Edges
Bill	01/10/2015	3136711	4J5691 Washer - 621B	Cutting Edges
Bill	01/10/2015	3136711	5T8525 Plate - hitch - 621B	Cutting Edges
Bill	01/10/2015	3136711	9J2323 Washer, hitch	Cutting Edges
Bill	01/10/2015	3136711	5T8528 Pin - Hitch (5T3016)	Cutting Edges

Bill	01/10/2015	3136711	7J 3663 Washer - Hitch (Bro Cutting Edges
Bill	01/10/2015	3136711	2J5637 Pin - Hitch - 621/631 Cutting Edges
Bill	05/10/2015	PR140075828	4K - 7463 *Seal William Adam:
Bill	05/10/2015	PR140075827	Emergency Service Fee William Adam:
Bill	06/10/2015	PR140075868	4K - 7463 *Seal William Adam:
Bill	06/10/2015	PR140075868	8D - 8829 Bearing William Adam:
Bill	06/10/2015	PR140075868	8J - 7596 Bearing William Adam:
Bill	06/10/2015	PR140075867	9J - 1676 Bearing William Adam:
Bill	06/10/2015	PR140075870	8J - 9910 Bearing William Adam:
Bill	06/10/2015	PR140075870	380 - 7378 BRG-SLV-CLA William Adam:
Bill	06/10/2015	PR140075869	3G - 4434 Pin A William Adam:
Bill	07/10/2015	PR140075922	7J - 8458 Bearing William Adam:
Bill	08/10/2015	PR140075963	8D - 8829 Bearing William Adam:
Bill	09/10/2015	PR140075991	374-1456 BRG - SLV - CLA William Adam:
Bill	09/10/2015	PR140075991	383 - 2124 Pin - CLA William Adam:
Bill	09/10/2015	28410	Bore and sleeve hitch, press TBAS Precisc
Bill	13/10/2015	PR140076067	8T-8919 Bolt William Adam:
Bill	13/10/2015	PR140076067	8T - 4223 Washer William Adam:
Bill	13/10/2015	PR140076067	7X-0372 Bolt William Adam:
Bill	13/10/2015	PR140076069	144-7293 Roller AS William Adam:
Bill	13/10/2015	PR140076069	434-1918 Roller - Cla William Adam:
Bill	13/10/2015	PR140076069	8I-1726 Scraper William Adam:
Bill	13/10/2015	PR140076069	8J-6535 Bearing William Adam:
Bill	13/10/2015	PR140076068	8I-1726 Scraper William Adam:
Bill	13/10/2015	PR140076068	0L-2340 Lock William Adam:
Bill	13/10/2015	PR140076068	8J-6535 Bearing William Adam:
Bill	13/10/2015	PR140076068	8J-6663 Pin William Adam:
Bill	13/10/2015	PR140076068	8J - 7553 Bar William Adam:
Bill	13/10/2015	PR140076070	2T-1960 Track William Adam:
Bill	20/10/2015	PR140076266	8L-5008 Elbow William Adam:
Bill	20/10/2015	PR140076266	5K-5068 Nipple William Adam:
Bill	21/10/2015	PR140076302	3D-9253 Connector-Pipe William Adam:
Bill	21/10/2015	PR140076302	2R-1922 Union William Adam:
Bill	21/10/2015	PR140076302	3H-0120 Elbow William Adam:
Bill	21/10/2015	PR140076303	8W-9267 *Shim William Adam:
Bill	21/10/2015	PR140076306	3G-8054 Clip William Adam:
Bill	21/10/2015	PR140076307	3G-8057 Clip William Adam:
Bill	21/10/2015	PR140076311	6G-0078 Breather William Adam:
Bill	21/10/2015	PR140076311	5S-7383 Bolt William Adam:
Credit	21/10/2015	CR140009745	144-7293 Roller AS PR1400 William Adam:
Bill	22/10/2015	PR140076346	5T-2836 Bar William Adam:
Bill	22/10/2015	PR140076347	325-3291 Roller AS William Adam:
Bill	22/10/2015	PR140076349	309-6942 *Hydo ADV 20Lit [William Adam:
Bill	22/10/2015	PR140076348	5P-5588 *Seal William Adam:
Bill	22/10/2015	PR140076348	7K-5449 Cone William Adam:
Bill	22/10/2015	PR140076348	7K-5448 Cup William Adam:
Bill	22/10/2015	PR140076348	144-7295 *Gasket William Adam:
Bill	27/10/2015	PR000628589	3G-7875 *Hose A William Adam:
Bill	27/10/2015	PR000628589	8I-1860 *Shim William Adam:
Bill	29/10/2015	PR000628832	8I-1860 *Shim William Adam:
Bill	29/10/2015	PR000628833	8I-1860 *Shim William Adam:
Credit	29/10/2015	CR140009769	2W-5540 Core A Rad William Adam:
Credit	31/10/2015	CR140009776	7K-5449 Cone William Adam:
Credit	31/10/2015	CR140009776	7K-5448 Cup William Adam:
Credit	31/10/2015	CR140009776	144-7295 *Gasket William Adam:
Credit	31/10/2015	CR140009777	8J-6535 Bearing William Adam:

Credit	31/10/2015	CR140009777	8J-6535 Bearing	William Adam:
Bill	12/11/2015	28600	Remove bearings in cat ditch	TBAS Precisc
Bill	02/12/2015	PR140077396	8X-4536 *Hose A	William Adam:
Bill	02/12/2015	PR140077398	7I-5406 *Hose AS	William Adam:
Bill	02/12/2015	PR140077398	7I-5409 *Hose AS	William Adam:
Bill	02/12/2015	PR140077398	7I-5490 *Hose AS	William Adam:
Bill	02/12/2015	PR140077398	7I-5489 *Hose AS	William Adam:
Credit	04/12/2015	CR140009857	5J-4988 *Seal A	William Adam:
Bill	11/12/2015	PR140077666	9Y-6089 *Gasket	William Adam:
Bill	14/12/2015	PR140077702	10R-9815 *Motor G Elec	William Adam:
Bill	14/12/2015	PR140077702	10R-9815 *Core Deposit	William Adam:
Bill	07/01/2016	PR000634375	6V-5221 Bolt	William Adam:
Bill	07/01/2016	PR000634375	9M-1974 Washer	William Adam:
Bill	07/01/2016	PR000634375	6V-7350 *Seal	William Adam:
Bill	07/01/2016	PR000634375	0R-0705 Pump GP WTR	William Adam:
Bill	07/01/2016	PR000634375	0R-0705 Core Deposit	William Adam:
Bill	07/01/2016	PR000634375	10I-1635 *Gasket	William Adam:
Bill	07/01/2016	PR000634375	6V-5063 *Seal O Ring	William Adam:
Bill	07/01/2016	PR000634375	7L-6580 *Seal O Ring	William Adam:
Bill	07/01/2016	PR000634375	7E-5555 *Gasket	William Adam:
Bill	07/01/2016	PR000634375	247-7133 Regulator - TE	William Adam:
Bill	07/01/2016	PR000634375	7E-7912 *Gasket	William Adam:
Bill	07/01/2016	PR000634375	3S-9643 *Seal-Lip Type Wat	William Adam:
Bill	07/01/2016	PR000634375	371-8946 *CM Hose Bulk	William Adam:
Bill	07/01/2016	PR000634375	2A-6392 *Glass	William Adam:
Bill	07/01/2016	PR000634375	10R-0400 *Motor GP Ele	William Adam:
Bill	07/01/2016	PR000634375	10R-0400 *Core Deposit	William Adam:
Bill	13/01/2016	PR000634848	9G-5319 *Seal G	William Adam:
Bill	14/01/2016	PR140078292	2D-0626 *Seal	William Adam:
Bill	14/01/2016	PR140078292	1M-9015 *Seal-O-Ring	William Adam:
Bill	14/01/2016	PR140078292	3D-8422 *Seal O Ring	William Adam:
Bill	14/01/2016	PR140078292	5B-3265 *Gasket	William Adam:
Bill	14/01/2016	PR140078292	3K-0360 *Seal-O-Ring Type:	William Adam:
Bill	14/01/2016	PR140078292	4D-1577 *Seal O Ring	William Adam:
Bill	14/01/2016	PR140078294	175-1928 Drum AS-Brak	William Adam:
Bill	14/01/2016	PR140078294	0R-8381 Shoe AS Brak	William Adam:
Bill	14/01/2016	PR140078294	0R-8381 Core Deposit	William Adam:
Bill	14/01/2016	PR140078293	3J-7283 Fitting-Grease	William Adam:
Bill	14/01/2016	PR140078293	5F-2830 Bearing	William Adam:
Bill	14/01/2016	PR140078293	3D-4637 Washer	William Adam:
Bill	14/01/2016	PR140078293	7F-7781 Washer	William Adam:
Bill	14/01/2016	PR140078293	7F-7783 Spring	William Adam:
Bill	14/01/2016	PR140078293	6D-6813 Bolt	William Adam:
Bill	14/01/2016	PR140078293	7F-7782 Retainer	William Adam:
Bill	14/01/2016	PR140078293	3D-4654 Washer	William Adam:
Bill	14/01/2016	PR140078293	2D-1683 Fitting	William Adam:
Bill	14/01/2016	PR140078293	2F-6066 *Ring	William Adam:
Bill	14/01/2016	PR140078293	5P-9949 Bearing	William Adam:
Bill	14/01/2016	PR140078293	9H-8839 *Seal	William Adam:
Credit	19/01/2016	CR000058272	0R-0705 Core Return PR00C	William Adam:
Credit	19/01/2016	CR140009955	0R-8381 Core Return PR14C	William Adam:
Credit	19/01/2016	CR140009956	10R-9815 *Core Return PR1	William Adam:
Bill	21/01/2016	PR140078486	446-8017 Roller Assem	William Adam:
Bill	12/02/2016	PR000637525	8I-1000 *Ring	William Adam:
Bill	12/02/2016	PR000637525	3E-6771 *Seal O Ring	William Adam:
Bill	12/02/2016	PR000637525	8C-3079 *Seal-O-Ring	William Adam:

Bill	12/02/2016	PR000637525	4J-0519 *Seal-O-Ring	William Adam:
Bill	12/02/2016	PR000637526	8T-7526 *O Ring Seal	William Adam:
Bill	12/02/2016	PR000637526	8I-1000 *Ring	William Adam:
Bill	18/02/2016	PR140079238	371-8113 *CM Hose Bulk	William Adam:
Bill	18/02/2016	PR140079236	217-5703 Receiver	William Adam:
Bill	18/02/2016	PR140079236	4L-6454 Bolt	William Adam:
Bill	18/02/2016	PR140079236	5P-1075 Washer	William Adam:
Bill	18/02/2016	PR140079236	9M-7958 Clamp	William Adam:
Bill	18/02/2016	PR140079236	6V-1867 Clip	William Adam:
Bill	18/02/2016	PR140079236	6V-1868 Clip	William Adam:
Bill	18/02/2016	PR140079237	3B-7826 Coupling	William Adam:
Bill	18/02/2016	PR140079237	8W-9059 Strip	William Adam:
Bill	19/02/2016	PR140079282	3B-6500 Elbow	William Adam:
Bill	19/02/2016	PR140079282	8B-9913 Elbow	William Adam:
Bill	19/02/2016	PR140079282	8X-9339 Pipe	William Adam:
Bill	19/02/2016	PR140079283	3L-8993 Nipple	William Adam:
Bill	19/02/2016	PR140079284	128-5051 Nipple-Plate	William Adam:
Bill	19/02/2016	PR140079281	9D0630 Cover G	William Adam:
Bill	19/02/2016	PR140079281	5P7467 Clip	William Adam:
Bill	19/02/2016	PR140079281	5P7466 Clip	William Adam:
Bill	19/02/2016	PR140079281	4T1314 Vent A	William Adam:
Credit	26/02/2016	CR140010049	8X-9339 Pipe	William Adam:
Credit	26/02/2016	CR140010049	128-5051 Nipple - Pipe	William Adam:
Bill	14/03/2016	PR140079798	446-8017 Roller Assem	William Adam:
Bill	14/03/2016	PR140079798	5J-2445 Bearing	William Adam:
Bill	14/03/2016	PR140079798	6V-9017 Striker AS	William Adam:
Bill	14/03/2016	PR140079799	7T-0020 *Lens-Dome Lamp	William Adam:
Bill	14/03/2016	PR140079800	9X-2044 Screw	William Adam:
Bill	14/03/2016	PR140079800	8X-7543 Facia	William Adam:
Bill	14/03/2016	PR140079800	3E-0109 Plug Rocker Switch	William Adam:
Bill	14/03/2016	PR140079800	7N-9943 *Lamp 24-Volt Don	William Adam:
Bill	14/03/2016	PR140079800	085-6445 Lock	William Adam:
Bill	14/03/2016	PR140079800	085-6446 Base	William Adam:
Bill	14/03/2016	PR140079800	085-6447 Retainer	William Adam:
Bill	14/03/2016	PR140079800	085-6448 Screw	William Adam:
Bill	14/03/2016	PR140079800	085-6449 *Packing	William Adam:
Bill	22/03/2016	PR000641118	3E-9862 Lucknut	William Adam:
Bill	22/03/2016	PR000641119	8F-4225 Cap Screw	William Adam:
Bill	11/05/2016	PR000645864	291-2165 Potentiomete	William Adam:
Bill	11/05/2016	PR000645865	136-1953 *CM Hose	William Adam:
Bill	11/05/2016	PR000645865	9X-2488 Clamp	William Adam:
Bill	11/05/2016	PR000645865	222-3115 *Oil-Penetrat	William Adam:
Bill	11/05/2016	PR000645865	222-3110 *Lubricant	William Adam:
Bill	11/05/2016	PR000645865	222-3112 *Saver-Batter	William Adam:
Bill	11/05/2016	PR000645865	280-1555 *Paste-Bluing	William Adam:
Bill	11/05/2016	PR000645865	222-3111 *Cleaner-Batt	William Adam:
Bill	12/05/2016	PR000645995	274-8879 *Kit-Waterval	William Adam:
Bill	31/05/2016	PR000647820	8D-7057 Valve A	William Adam:
Bill	31/05/2016	PR000647820	6G-3641 Cylinder G	William Adam:
Bill	31/05/2016	SR140008029	Machine involced in incident	William Adam:
Bill	31/05/2016	SR140008029	Envir/Consum Chg	William Adam:
Bill	20/06/2016	PR140081819	207-2528 Gage-Oil Lev	William Adam:
Bill	20/06/2016	PR140081819	6V-5553 *Seal O Ring	William Adam:
Bill	20/06/2016	PR140081819	5P-0599 Clamp	William Adam:
Bill	20/06/2016	PR140081819	371-8954 *CM Hose Bulk	William Adam:
Bill	20/06/2016	PR140081818	3K-0715 *Seal	William Adam:

Bill	20/06/2016	PR140081818	9M-5024 *Seal O Ring	William Adam:
Bill	20/06/2016	PR140081818	9F-7283 *Ring	William Adam:
Bill	06/07/2016	PR000651401	5K-5288 *Seal G	William Adam:
Bill	06/07/2016	PR000651401	6V-8188 Nut	William Adam:
Bill	06/07/2016	PR000651401	7X-0550 Washer	William Adam:
Bill	06/07/2016	PR000651401	5P-2228 Bolt	William Adam:
Bill	06/07/2016	PR000651401	8T-4223 Washer	William Adam:
Bill	06/07/2016	PR000651401	8S-0023 Clip	William Adam:
Bill	06/07/2016	PR000651401	8S-0024 Clip	William Adam:
Bill	06/07/2016	PR000651401	5P-1717 Clamp	William Adam:
Bill	06/07/2016	PR000651401	5P-1296 *CM-Hose STK	William Adam:
Bill	07/07/2016	PR000651519	270-6942 *Shim	William Adam:
Bill	07/07/2016	PR000651519	270-6944 *Shim	William Adam:
Bill	07/07/2016	PR000651519	279-9902 *Seal Ring	William Adam:
Bill	07/07/2016	PR000651519	279-9903 *Seal Ring	William Adam:
Bill	07/07/2016	PR000651519	279-9904 *Seal Ring	William Adam:
Bill	07/07/2016	PR000651519	279-9905 *Seal Ring	William Adam:
Bill	07/07/2016	PR000651519	7X-1548 *Seal	William Adam:
Bill	07/07/2016	PR000651519	9V-0344 Pin	William Adam:
Bill	07/07/2016	PR000651519	7P-7975 Latch	William Adam:
Bill	07/07/2016	PR000651519	156-6793 Spring-Latch	William Adam:
Bill	27/07/2016	42	Cigarette sockets for camera	Sparks N Spa
Bill	18/08/2016	PR000655221	8D-7047 Pin	William Adam:
Bill	18/08/2016	PR000655221	8D-7052 Spring	William Adam:
Bill	18/08/2016	PR000655221	8D-7057 Valve A	William Adam:
Bill	18/08/2016	PR000655221	8S-7803 Retainer	William Adam:
Bill	29/08/2016	51	12/24 Volt AM/FM radio	Sparks N Spa
Bill	29/08/2016	51	Cigarette socket for camera	Sparks N Spa
Bill	13/11/2017	103630	Crane Hire to lift Apron - Tac	Mildura Crane
Bill	14/11/2017	PR140091719	9N-1941 Clamp	William Adam:
Bill	14/11/2017	PR140091719	8T-2561 Washer	William Adam:
Bill	14/11/2017	PR140091719	9B-7237 Screw	William Adam:
Bill	16/11/2017	PR140091765	7E-8630 *Hose-Hump	William Adam:
Bill	16/11/2017	PR140091765	5WA1848 Threadlocker 50M	William Adam:
Bill	16/11/2017	16294784	8X20M88ZPB CL8.8 High Tc	Konnect
Bill	16/11/2017	16294784	8MNN Nylon Insert Lock Nut	Konnect
Bill	16/11/2017	16294784	516X1.2ZPEW Brt Ms Wash	Konnect
Bill	16/11/2017	16294784	516X34ZPEW Brt Ms Wash	Konnect
Bill	17/11/2017	PR140091787	236-4608 *Switch As-Ro	William Adam:
Bill	17/11/2017	PR140091786	Emerg. Serv. Fee	William Adam:
Bill	21/11/2017	16302725	8X25MZPFHSS Socket Csk	Konnect
Bill	21/11/2017	PR140091928	5P-8250 Washer	William Adam:
Bill	21/11/2017	PR140091928	2J-3507 Nut	William Adam:
Bill	22/11/2017	INV-32691	Machine alloy pie to fit mast	TBAS Precisc
Bill	23/11/2017	PR140091886	479-5400 Paint-Yellow	William Adam:
Bill	28/11/2017	PR140091989	7D-1949 Cutting Edge	William Adam:
Bill	28/11/2017	PR140091989	4K-0367 Nut	William Adam:
Bill	28/11/2017	PR140091989	4F-7827 Bolt	William Adam:
Bill	28/11/2017	PR140091989	2J-3506 Nut	William Adam:
Bill	28/11/2017	PR140091989	3F-5108 Bolt	William Adam:
Bill	28/11/2017	00017666	Labour - Installed shim to hit	Bottrell Mecha
Bill	13/12/2017	PR140092350	1R-0732 Element As	William Adam:
Bill	13/12/2017	PR140092350	1R-0762 Filter A-Fue	William Adam:
Bill	13/12/2017	PR140092350	1R-0773 Element AS	William Adam:
Bill	13/12/2017	PR140092350	1R-1808 Filter As-Lu	William Adam:
Bill	13/12/2017	PR140092350	2H-3928 Seal	William Adam:

Bill	13/12/2017	PR140092350	2H-3931 Seal	William Adam:
Bill	13/12/2017	PR140092350	3D-2824 Seal O Ring	William Adam:
Bill	13/12/2017	PR140092350	4J-3815 Gasket	William Adam:
Bill	13/12/2017	PR140092350	5F-0149 Ring	William Adam:
Bill	13/12/2017	PR140092350	5K-1770 Seal O Ring	William Adam:
Bill	13/12/2017	PR140092350	6I-0274 Element AS	William Adam:
Bill	13/12/2017	PR140092350	7M-8485 Seal	William Adam:
Bill	13/12/2017	PR140092350	8H-7521 Seal O Ring	William Adam:
Bill	13/12/2017	PR140092350	9X-2205 Filter Kit	William Adam:
Bill	13/12/2017	PR140092350	9X-8600 Seal O Ring	William Adam:
Bill	13/12/2017	PR140092350	103-8236 Ring	William Adam:
Bill	13/12/2017	PR140092350	326-1643 Filter As	William Adam:
Bill	13/12/2017	PR140092350	326-1644 Filter As	William Adam:
Bill	13/12/2017	PR140092350	452-6010 Prime Grease 450	William Adam:
Bill	13/12/2017	PR140092350	SOS003 Oil Smpl Kit	William Adam:
Bill	13/12/2017	PR140092350	SOS004 Coolant Sample Kit	William Adam:
Bill	13/12/2017	PR140092350	5WA0392 Box Kit 1000HR	William Adam:
Bill	13/12/2017	PR140092349	1R-0732 Element As	William Adam:
Bill	13/12/2017	PR140092349	1R-0762 Filter A-Fue	William Adam:
Bill	13/12/2017	PR140092349	1R-0773 Element As	William Adam:
Bill	13/12/2017	PR140092349	1R-1808 Filter As-Lu	William Adam:
Bill	13/12/2017	PR140092349	2H-3928 Seal	William Adam:
Bill	13/12/2017	PR140092349	2H-3931 Seal	William Adam:
Bill	13/12/2017	PR140092349	3D-2824 Seal O Ring	William Adam:
Bill	13/12/2017	PR140092349	4J-3815 Gasket	William Adam:
Bill	13/12/2017	PR140092349	5F-0149 Ring	William Adam:
Bill	13/12/2017	PR140092349	5K-1770 Seal O Ring	William Adam:
Bill	13/12/2017	PR140092349	6I-0274 Element As	William Adam:
Bill	13/12/2017	PR140092349	6I-2508 Element As	William Adam:
Bill	13/12/2017	PR140092349	7M-8485 Seal	William Adam:
Bill	13/12/2017	PR140092349	8H-7521 Seal O Ring	William Adam:
Bill	13/12/2017	PR140092349	9X-2205 Filter Kit	William Adam:
Bill	13/12/2017	PR140092349	9X-8600 Seal O Ring	William Adam:
Bill	13/12/2017	PR140092349	103-8236 Ring	William Adam:
Bill	13/12/2017	PR140092349	119-3355 Filter-Air	William Adam:
Bill	13/12/2017	PR140092349	126-1814 Element-Filter	William Adam:
Bill	13/12/2017	PR140092349	174-8145 Filter-Air	William Adam:
Bill	13/12/2017	PR140092349	326-1643 Filter As	William Adam:
Bill	13/12/2017	PR140092349	326-1644 Filter As	William Adam:
Bill	13/12/2017	PR140092349	452-6010 Prime Grease 450	William Adam:
Bill	13/12/2017	PR140092349	SOS003 OilSmpl Kit	William Adam:
Bill	13/12/2017	PR140092349	SOS004 Coolant Sample Kit	William Adam:
Bill	13/12/2017	PR140092349	5WA0392 Box Kit 1000hr	William Adam:
Bill	14/12/2017	2010968813	1P1238 Stem A Col	Hastings Deer
Bill	14/12/2017	PR140092377	6I-0273 Element As	William Adam:
Bill	14/12/2017	PR140092377	6I-2507 Element AS	William Adam:
Bill	14/12/2017	PR140092377	9T-0973 Filter	William Adam:
Bill	14/12/2017	PR140092377	108-1153 Element	William Adam:
Bill	14/12/2017	PR140092379	6I-0273 Element As	William Adam:
Bill	14/12/2017	PR140092379	6I-2507 Element As	William Adam:
Bill	14/12/2017	PR140092379	6I-2508 Element As	William Adam:
Bill	14/12/2017	PR140092379	9T-0973 Filter	William Adam:
Bill	14/12/2017	PR140092379	119-3355 Filter-Air	William Adam:
Bill	14/12/2017	PR140092379	126-1814 Element-Filter	William Adam:
Bill	14/12/2017	PR140092379	174-8145 Filter-Air	William Adam:
Bill	14/12/2017	PR140092376	8Y-4617 Handle A	William Adam:

Bill	14/12/2017	PR140092378	108-1153 Element	William Adam:
Bill	14/12/2017	PR140092378	190-0760 Desiccant	William Adam:
Bill	15/12/2017	PR140092403	6G-0078 Breather	William Adam:
Bill	18/12/2017	PR140092434	242-7009 Latch as	William Adam:
Bill	21/12/2017	PR140092504	8J-7734 Hose A	William Adam:
Bill	21/12/2017	PR140092505	276-7018 Kit Cap Plug	William Adam:
Bill	21/12/2017	PR140092505	309-6942 Hydo Adv 20Lit Dr	William Adam:
Bill	21/12/2017	PR140092506	165-0020 XT3 ES Hose	William Adam:
Bill	21/12/2017	PR140092506	4J-0520 Seal-O-Ring	William Adam:
Bill	21/12/2017	PR140092506	4J-5267 Seal-O-Ring	William Adam:
Bill	21/12/2017	PR140092506	Hose Assy Lab	William Adam:
Bill	01/01/2018	PR140092554	190-0760 Desiccant CA	William Adam:
Bill	16/01/2018	PR000703156	190-0760 Desiccant Ca	William Adam:
Bill	16/01/2018	PR000703156	7Y-3173 Screw-Button Head	William Adam:
Bill	16/01/2018	PR000703156	299-3398 Bolt Hex	William Adam:
Bill	16/01/2018	PR000703156	421-3152 Nut-Hex	William Adam:
Bill	16/01/2018	PR000703156	421-3183 Bolt-Hex Head	William Adam:
Bill	16/01/2018	PR000703156	5P-4295 Clip	William Adam:
Bill	16/01/2018	PR000703156	Emergency Service Fee	William Adam:
Bill	16/01/2018	PR000703155	5C-8811 Blade A	William Adam:
Bill	16/01/2018	PR000703155	104-2091 Screw	William Adam:
Bill	16/01/2018	PR000703155	107-1964 Screw-Pan Head €	William Adam:
Bill	16/01/2018	PR000703155	9X-2042 Screw	William Adam:
Bill	16/01/2018	PR000703155	8T-4199 Bolt	William Adam:
Bill	16/01/2018	PR000703155	7Y-7256 Screw	William Adam:
Bill	16/01/2018	PR000703155	9X-2044 Screw	William Adam:
Bill	16/01/2018	PR000703155	133-7023 Pulley As-IdlerRep	William Adam:
Bill	16/01/2018	PR000703155	9M-0164 Clamp	William Adam:
Bill	16/01/2018	PR000703155	3T-3434 Plug	William Adam:
Bill	16/01/2018	PR000703155	7L-2894 Gasket	William Adam:
Bill	16/01/2018	PR000703155	9Y-6089 Gasket	William Adam:
Bill	16/01/2018	PR000703155	173-0888 Spider GP	William Adam:
Bill	16/01/2018	PR000703155	8M-5010 Seal O Ring	William Adam:
Bill	16/01/2018	PR000703155	8M-5661 Seal O Ring	William Adam:
Bill	16/01/2018	PR000703155	8C-3089 Seal O Ring	William Adam:
Bill	16/01/2018	PR000703155	5P-7464 Clip	William Adam:
Bill	16/01/2018	PR000703155	5P-7465 Clip	William Adam:
Bill	16/01/2018	PR000703155	6V-1249 Grommet	William Adam:
Bill	16/01/2018	PR000703155	5P-4295 Clip	William Adam:
Bill	17/01/2018	PR000703280	2H-2665 Seal	William Adam:
Bill	17/01/2018	PR000703280	216-0273 Seal-Lip Typ	William Adam:
Bill	17/01/2018	PR000703280	5P-1086 Seal	William Adam:
Bill	19/01/2018	69208	5m x 910 Aluminium Flywire	Mallee Buildin:
Bill	23/01/2018	PR000703859	279-6722 Harness AS	William Adam:
Bill	31/01/2018	1232	Replace floor on Apron and r	Pumpa 24/7 E
Bill	31/01/2018	1232	Materials	Pumpa 24/7 E
Bill	14/02/2018	PR000705994	352-2109 Pump GP-Wate	William Adam:
Bill	14/02/2018	PR000705994	005-8593 Seal	William Adam:
Bill	14/02/2018	PR000705994	117-1385 Seal O Ring	William Adam:
Bill	14/02/2018	PR000705994	2M-4453 Seal O Ring	William Adam:
Bill	14/02/2018	PR000705994	5F-8000 Ring	William Adam:
Bill	14/02/2018	PR000705994	208-6054 Clamp-T'Bolt	William Adam:
Bill	14/02/2018	PR000705994	200-2258 Gasket	William Adam:
Bill	14/02/2018	PR000705994	280-6794 Hose	William Adam:
Bill	14/02/2018	PR000705994	347-3148 Clamp Band	William Adam:
Bill	15/02/2018	PR140093534	189-3158 Suppressor	William Adam:

Bill	16/02/2018	PR140093567	371-8094 *CM hose bulk	William Adam:
Bill	16/02/2018	PR000706255	4N-8398 Hose	William Adam:
Bill	21/02/2018	PR000706749	161-1703 Sensor GP	William Adam:
Bill	21/02/2018	PR000706749	214-7568 Seal O Ring	William Adam:
Bill	21/02/2018	PR000706749	102-8803 Recptacle Ki	William Adam:
Bill	21/02/2018	PR000706749	155-2260 Plug Kit-Con	William Adam:
Bill	21/02/2018	PR000706749	264-4297 Sensor Temp	William Adam:
Bill	21/02/2018	PR000706749	8L-2786 O Ring	William Adam:
Bill	25/02/2018	INV-0148	HOSE 1 ' ID 4000 PSI	N.E Mechanic:
Bill	25/02/2018	INV-0148	Adaptor Female 3/8	N.E Mechanic:
Bill	25/02/2018	INV-0148	NIPPLE 3/8 X 1/4 NPT	N.E Mechanic:
Bill	25/02/2018	INV-0148	SWIVEL 90' FEM F/F O-RIN	N.E Mechanic:
Bill	02/03/2018	PR000707740	208-7448 Clamp-T'bolt	William Adam:
Bill	02/03/2018	PR000707740	7E-8630 Hose-Hump	William Adam:
Bill	02/03/2018	PR000707740	8C-3089 Seal O ring	William Adam:
Bill	02/03/2018	PR000707740	2N-2765 Bolt	William Adam:
Bill	02/03/2018	PR000707740	2N-2766 Lock Nut	William Adam:
Bill	05/03/2018	PR000707895	5L-8854 Ring	William Adam:
Bill	05/03/2018	PR000707899	165-5970 Switch GP-Toggle	William Adam:
Bill	06/03/2018	PR000708055	354-2859 Spacer	William Adam:
Bill	07/03/2018	PR000708197	367-3070 Tool Gp	William Adam:
Bill	07/03/2018	PR000708197	Emerg.Serv.Fee	William Adam:
Bill	07/03/2018	PR000708196	387-9433 Injector Gp-Fuel	William Adam:
Bill	07/03/2018	PR000708196	149-5240 Injector Ring - BA	William Adam:
Bill	07/03/2018	PR000708196	293-0730 Ring Backup	William Adam:
Bill	07/03/2018	PR000708196	109-3207 Injector - seal O R	William Adam:
Bill	07/03/2018	PR000708196	148-2903 Injector - seal O R	William Adam:
Bill	07/03/2018	PR000708196	235-9651 Bolt-Socket	William Adam:
Bill	07/03/2018	PR000708196	4C-6161 Brush	William Adam:
Bill	27/03/2018	PR140094417	309-6942 Hydo Adv 20lit Dr	William Adam:
Bill	04/04/2018	PR000710761	5P-5643 *M Seal STK	William Adam:
Bill	04/04/2018	PR000710761	1P-4278 Clamp	William Adam:
Bill	04/04/2018	PR000710761	256-5311 Core As-Rad	William Adam:
Bill	04/04/2018	PR000710761	5P-6442 *CM-Hose STK	William Adam:
Bill	04/04/2018	PR000710761	6L-8617 Cap	William Adam:
Bill	04/04/2018	PR000710761	8S-9379 *Hose	William Adam:
Bill	04/04/2018	PR000710761	371-8946 *CM Hose bulk	William Adam:
Bill	04/04/2018	PR000710761	111-7092 *Hose	William Adam:
Bill	04/04/2018	PR000710761	209-4573 Clamp-T'Bolt	William Adam:
Bill	04/04/2018	PR000710761	212-6933 Clamp-T'Bolt	William Adam:
Bill	04/04/2018	PR000710763	5G-5432 Spacer	William Adam:
Bill	04/04/2018	PR000710763	3S-8664 Clip	William Adam:
Bill	04/04/2018	PR000710763	4L-6454 Bolt	William Adam:
Bill	04/04/2018	PR000710763	5K-5338 Clip Large	William Adam:
Bill	04/04/2018	PR000710763	5P-1075 Washer	William Adam:
Bill	04/04/2018	PR000710763	5S-7379 Bolt	William Adam:
Bill	04/04/2018	PR000710763	8T-2501 Bolt	William Adam:
Bill	04/04/2018	PR000710763	6V-8801 Nut	William Adam:
Bill	04/04/2018	PR000710763	8S-0948 Clip	William Adam:
Bill	04/04/2018	PR000710763	8T-4896 Washer	William Adam:
Bill	05/04/2018	PR000710903	248-6816 Mount	William Adam:
Bill	05/04/2018	PR000710903	8T-4121 Washer-Hard	William Adam:
Bill	05/04/2018	PR000710903	8T-4186 Bolt	William Adam:
Bill	05/04/2018	PR000710903	121-3307 Mount As Resilien	William Adam:
Bill	05/04/2018	PR000710903	115-6433 Washer	William Adam:
Bill	05/04/2018	PR000710903	8T-6466 Bolt	William Adam:

Bill	05/04/2018	PR000710903	8T-4196 Bolt	William Adam:
Bill	05/04/2018	PR000710903	1P-4278 Clamp	William Adam:
Bill	05/04/2018	PR000710903	5P-6442 CM-Hose STK	William Adam:
Bill	05/04/2018	PR000710903	3E-5169 Guard	William Adam:
Bill	05/04/2018	PR000710903	139-2116 Switch As-To	William Adam:
Bill	05/04/2018	PR000710903	7K-1181 Strap cable	William Adam:
Bill	05/04/2018	PR000710903	8T-9405 Bolt	William Adam:
Bill	05/04/2018	PR000710903	418-1936 Grommet-Ym	William Adam:
Bill	05/04/2018	PR000710903	1S-4305 Washer	William Adam:
Bill	05/04/2018	PR000710903	8T-8919 Bolt	William Adam:
Bill	05/04/2018	PR000710903	00C691283 ESF	William Adam:
Bill	05/04/2018	PR000710904	248-6816 Mount	William Adam:
Bill	05/04/2018	PR000710904	9L-8781 Washer	William Adam:
Bill	05/04/2018	PR000710904	115-6433 Washer	William Adam:
Bill	05/04/2018	PR000710904	213-6216 Harness As	William Adam:
Bill	05/04/2018	PR000710904	1S-4305 Washer	William Adam:
Bill	05/04/2018	PR000710902	147-2355 CM Seal	William Adam:
Bill	06/04/2018	PR000711039	248-6816 Mount	William Adam:
Bill	06/04/2018	PR000711038	5D-2645 Clamp	William Adam:
Bill	06/04/2018	PR000711038	108-1610 Clamp	William Adam:
Bill	06/04/2018	PR000711038	3G-4005 Link	William Adam:
Bill	06/04/2018	INV-0164	Swivel 90Long FEM F/F ORI N.E	Mechanic:
Bill	06/04/2018	INV-0164	Swivel STR FEM F/F O-Ring N.E	Mechanic:
Bill	06/04/2018	INV-0164	Swivel 90' FEM F/F O-Ring N.E	Mechanic:
Bill	06/04/2018	INV-0164	STEM 9/16"JIC-F*-06 Hose N.E	Mechanic:
Bill	06/04/2018	INV-0164	Swivel 90' FEM F/F O-Ring N.E	Mechanic:
Bill	06/04/2018	INV-0164	Swivel STR FEM F/F O-Ring N.E	Mechanic:
Bill	06/04/2018	INV-0164	Ferrule Body C1T/2AT/C5C N.E	Mechanic:
Bill	06/04/2018	INV-0164	Hose 3/8 N/Skive SAE100R N.E	Mechanic:
Bill	06/04/2018	INV-0164	Swivel STR FEM F/F O-Ring N.E	Mechanic:
Bill	06/04/2018	INV-0164	Swivel 45' FEM F/F O-Ring N.E	Mechanic:
Bill	06/04/2018	INV-0164	Hose 1/2 N/Skive SAE100R N.E	Mechanic:
Bill	09/04/2018	PR140094713	6C-3680 Rivet-Pop	William Adam:
Bill	10/04/2018	PR140094760	300-1710 Washer	William Adam:
Bill	12/04/2018	PR000711630	10R-0399 Motor GP Ele	William Adam:
Bill	12/04/2018	PR000711630	10R-0399 Core Deposit	William Adam:
Bill	12/04/2018	PR000711630	9Y-6089 Gasket	William Adam:
Bill	12/04/2018	PR140094820	296-6677 Bumper-Wear	William Adam:
Bill	01/05/2018	PR000713474	248-5513 Regulator	William Adam:
Bill	01/05/2018	PR000713474	3F-5792 Seal	William Adam:
Bill	01/05/2018	PR000713474	366-8857 DM Harness	William Adam:
Bill	01/05/2018	PR000713475	6V-7744 Locknut	William Adam:
Bill	01/05/2018	PR000713475	326-0610 Latch As	William Adam:
Bill	01/05/2018	PR140095217	255-9160 Hose As	William Adam:
Bill	03/05/2018	PR000713646	326-0614 Cam	William Adam:
Bill	14/05/2018	PR000714805	279-2589 Pulley As	William Adam:
Bill	14/05/2018	PR000714805	330-0663 Belt	William Adam:
Bill	15/05/2018	PR000714935	5P-6863 Clip	William Adam:
Credit	16/05/2018	CR000063729	10R-0399 Partial CRDT	William Adam:
Bill	17/05/2018	PR000715161	5T-9093 Gage-Oil	William Adam:
Bill	18/05/2018	PR000715252	4D-0306 Gasket	William Adam:
Bill	25/05/2018	PR140095801	207-2528 Gage-Oil Lev	William Adam:
Bill	18/06/2018	PR140096279	381-2509 Tensioner	William Adam:
Bill	18/06/2018	PR140096279	381-2512 Pulley	William Adam:
Bill	18/06/2018	PR140096279	7X-0388 Bolt	William Adam:
Bill	18/06/2018	PR140096278	279-2589 Pulley As	William Adam:

Bill	18/06/2018	PR140096278	7X-0388 Bolt	William Adam:
Bill	18/06/2018	PR140096278	8T-4223 Washer	William Adam:
Bill	18/06/2018	PR140096278	8W-9267 Shim	William Adam:
Bill	18/06/2018	PR140096302	Emerg serv fee	William Adam:
Bill	18/06/2018	PR140096302	emerg frt pts in	William Adam:
Bill	18/06/2018	PR140096303	394-0210 Trunnion-ym	William Adam:
Bill	18/06/2018	PR140096304	7J-4983 Cap Brg	William Adam:
Bill	18/06/2018	PR140096304	241-1855 Bolt-Hex HD	William Adam:
Bill	18/06/2018	PR140096304	380-7563 BRG-SLV-YM	William Adam:
Bill	18/06/2018	PR140096305	5WA2915 Petroleum Jel 40C	William Adam:
Bill	18/06/2018	PR140096305	5WA1804 Flex gasket make	William Adam:
Bill	26/06/2018	PR140096515	6F-3930 Core-Valve	William Adam:
Bill	26/06/2018	PR140096515	9K-7951 Cap Valve	William Adam:
Bill	26/06/2018	PR140096515	2D-2444 Seal	William Adam:
Bill	26/06/2018	PR140096515	3D-8422 Seal O Ring	William Adam:
Bill	26/06/2018	PR140096515	4D-1577 Seal O Ring	William Adam:
Bill	26/06/2018	PR140096515	6F-4855 Seal	William Adam:
Bill	26/06/2018	PR140096520	2P-1823 Cup	William Adam:
Bill	26/06/2018	PR140096520	2P-1824 Cone	William Adam:
Bill	26/06/2018	PR140096520	3D-2239 Valve G	William Adam:
Bill	26/06/2018	PR140096520	6G-8370 Shim Pack	William Adam:
Bill	26/06/2018	PR140096520	9G-5319 Seal G	William Adam:
Bill	26/06/2018	PR140096520	030-8535 Bolt	William Adam:
Bill	26/06/2018	PR140096520	4D-1557 Seal O Ring	William Adam:
Bill	26/06/2018	PR140096520	4F-2411 Seal	William Adam:
Bill	26/06/2018	PR140096520	377-7400 Cone_BRG-YM	William Adam:
Bill	26/06/2018	PR140096520	377-7401 Cup-BRG-YM	William Adam:
Bill	29/06/2018	SR140009096	Labour	William Adam:
Bill	29/06/2018	SR140009096	KM Travel Heavy	William Adam:
Bill	29/06/2018	SR140009096	Envir/Consum Charge	William Adam:
Bill	03/07/2018	PR000719160	1M-9015 Seal-O-Rin	William Adam:
Bill	03/07/2018	PR000719160	5P-6628 Wire-Lock	William Adam:
Bill	09/07/2018	PR140096822	8J-6913 Retainer	William Adam:
Bill	09/07/2018	PR140096821	2D-5248 Gasket	William Adam:
Bill	09/07/2018	PR140096821	7X-7958 Clamp-Hose	William Adam:
Bill	09/07/2018	PR140096821	6D-4733 Gasket	William Adam:
Bill	09/07/2018	PR140096821	8M-5010 Seal O Tin	William Adam:
Bill	09/07/2018	PR140096821	5P-2094 CM-Hose Stk	William Adam:
Bill	09/07/2018	PR140096821	5J-3316 Gasket	William Adam:
Bill	09/07/2018	PR140096821	9X-6620 Nut	William Adam:
Bill	09/07/2018	PR140096821	161-3411 Gasket	William Adam:
Bill	09/07/2018	PR140096821	116-3715 Stud	William Adam:
Bill	09/07/2018	PR140096821	4P-4369 Spacer	William Adam:
Bill	09/07/2018	PR140096821	418-6781 Stud Taperlo	William Adam:
Bill	09/07/2018	PR140096821	1P-7115 Mount AS	William Adam:
Bill	09/07/2018	PR140096821	6G-9943 Nolt	William Adam:
Bill	09/07/2018	PR140096821	10R-3667 Core AS Oil	William Adam:
Bill	09/07/2018	PR140096821	10R-3367 Core Deposit	William Adam:
Bill	09/07/2018	PR140096821	5T-9518 Hose AS	William Adam:
Bill	09/07/2018	PR140096821	5T-9520 Hose AS	William Adam:
Bill	09/07/2018	PR140096821	215-8029 Hose AS	William Adam:
Bill	09/07/2018	PR140096820	8T-6703 Clamp	William Adam:
Bill	09/07/2018	PR140096820	3D-2824 Seal O Ring	William Adam:
Bill	09/07/2018	PR140096820	6V-9746 Seal-O-Ring-	William Adam:
Bill	09/07/2018	PR140096820	1H-7339 Seal	William Adam:
Bill	09/07/2018	PR140096820	4J-0522 Seal-O-Ring	William Adam:

Bill	09/07/2018	PR140096820	5F-8000 Ring	William Adam:
Bill	09/07/2018	PR140096820	8M-4987 Seal O Ring	William Adam:
Bill	09/07/2018	PR140096820	8M-5010 Seal O Ring	William Adam:
Bill	09/07/2018	PR140096820	8M-5661 SEal O Ring	William Adam:
Bill	09/07/2018	PR140096820	5P-1292 CM-Hose STK	William Adam:
Bill	09/07/2018	PR140096820	6G-0078 Breatherr	William Adam:
Bill	09/07/2018	PR140096820	4J-8251 Grommet	William Adam:
Bill	09/07/2018	PR140096820	4J-8252 Guage-Sight HYDR	William Adam:
Bill	09/07/2018	PR140096820	2K-7973 Nut	William Adam:
Bill	09/07/2018	PR140096820	5M-2894 Washer-Hard 10.2	William Adam:
Bill	09/07/2018	PR140096820	9H6454 Gasket	William Adam:
Bill	09/07/2018	PR140096820	3T-3434 Plug	William Adam:
Bill	09/07/2018	PR140096820	7L-2894 Gasket	William Adam:
Bill	09/07/2018	PR140096820	9Y-6089 Gasket	William Adam:
Bill	09/07/2018	PR140096820	9X-6620 Nut	William Adam:
Bill	09/07/2018	PR140096820	6V-5839 Washer-Hard	William Adam:
Bill	09/07/2018	PR140096820	418-6781 Stud Taperlo	William Adam:
Bill	09/07/2018	PR140096820	228-7089 Seal-O-Ring	William Adam:
Bill	09/07/2018	PR140096820	214-7568 Seal-O Ring	William Adam:
Bill	09/07/2018	PR140096820	8L-2779 O Ring	William Adam:
Bill	09/07/2018	PR140096820	8L-2786 O Ring	William Adam:
Bill	09/07/2018	PR140096820	3P-1156 SEal-O-Ring	William Adam:
Bill	09/07/2018	PR140096820	246-6036 Hose	William Adam:
Bill	09/07/2018	PR140096820	284-3502 Clamp-Band	William Adam:
Bill	09/07/2018	PR140096820	1P-0451 Gasket	William Adam:
Bill	09/07/2018	PR140096820	3E-8017 Locknut	William Adam:
Bill	09/07/2018	PR140096820	6V-8189 Nut	William Adam:
Bill	09/07/2018	PR140096820	8C-**8/ Washer	William Adam:
Bill	09/07/2018	PR140096820	2S-0795 Gasket	William Adam:
Bill	09/07/2018	PR140096820	8T-9405 Bolt	William Adam:
Bill	09/07/2018	PR140096820	3E-5239 Relay A	William Adam:
Bill	09/07/2018	PR140096820	5M-7329 Seal O Ring	William Adam:
Bill	09/07/2018	PR140096820	263-2934 Hose AS	William Adam:
Bill	09/07/2018	PR140096820	199-7686 Hose AS	William Adam:
Bill	09/07/2018	PR140096820	321-7076 Hose AS	William Adam:
Bill	11/07/2018	PR000719902	197-8419 Gasket	William Adam:
Bill	11/07/2018	PR000719902	1U-5516 Disc	William Adam:
Bill	11/07/2018	PR000719902	1P-3708 Seal	William Adam:
Bill	11/07/2018	PR000719902	1P-3705 Seal	William Adam:
Bill	11/07/2018	PR000719902	1P-3704 Seal	William Adam:
Bill	11/07/2018	PR000719903	2D-5248 Gasket	William Adam:
Bill	11/07/2018	PR000719903	175-7896 Seal-O-Ring	William Adam:
Bill	11/07/2018	PR000719903	5P-1292 CM-Hose STK	William Adam:
Bill	11/07/2018	PR000719903	5F-0149 Ring	William Adam:
Bill	11/07/2018	PR000719903	8M-7160 Magnet	William Adam:
Bill	12/07/2018	PR000720041	6T-3642 Breaker	William Adam:
Bill	12/07/2018	PR000720041	6V-8376 Screw	William Adam:
Bill	12/07/2018	PR000720041	9B-7233 Lock Washer	William Adam:
Bill	12/07/2018	PR000720041	125-1302 Switch AS	William Adam:
Bill	13/07/2018	PR000720159	228-6892 Harness AS	William Adam:
Bill	19/07/2018	SR140009129	SC09 Assist in lifting our eng	William Adam:
Bill	20/07/2018	PR000720815	294-3342 Cap As-Rad	William Adam:
Bill	20/07/2018	PR000720816	6V-8801 Nut	William Adam:
Bill	20/07/2018	PR000720816	7X-0291 Bolt	William Adam:
Bill	20/07/2018	PR000720816	8T-4896 Washer	William Adam:
Bill	20/07/2018	PR000720816	2A-6392 Glass	William Adam:

Bill	25/07/2018	PR000721205	5H-7844 Gasket	William Adam:
Bill	25/07/2018	PR000721204	5T-9093 Gage-Oil	William Adam:
Bill	25/07/2018	PR000721204	1P-4579 Flange	William Adam:
Bill	31/07/2018	PR000721722	2A-1913 Gasket	William Adam:
Bill	31/07/2018	PR000721722	147-2675 Instal SLV	William Adam:
Bill	31/07/2018	PR000721721	360-3682 Plug-O-Ring	William Adam:
Bill	31/07/2018	PR000721721	238-5082 Seal-O-Ring	William Adam:
Bill	31/07/2018	PR000721721	214-7567 Seal-O-Ring	William Adam:
Bill	31/07/2018	PR000721721	0S-0519 Plug	William Adam:
Bill	31/07/2018	PR000721721	298-7137 Bolt Hex	William Adam:
Bill	31/07/2018	PR000721721	285-4074 Seal GP-CSHA	William Adam:
Bill	31/07/2018	PR000721721	9Y-0810 Sleeve	William Adam:
Bill	31/07/2018	PR000721721	190-6114 Gasket-Oil	William Adam:
Bill	31/07/2018	PR000721721	5WA1830 Sealant Flange	William Adam:
Bill	31/07/2018	PR000721721	5WA1835 Retaining compou	William Adam:
Bill	31/07/2018	PR000721721	5WA1850 Primer Sealant	William Adam:
Bill	31/07/2018	PR000721721	9X-8268 Washer	William Adam:
Bill	31/07/2018	PR000721725	Emerg.Serv.Fee	William Adam:
Bill	31/07/2018	PR000721726	9W-5531 Tube A	William Adam:
Bill	31/07/2018	PR000721727	246-7514 Insert Kit	William Adam:
Bill	31/07/2018	PR000721727	1U-8173 Drill-12.2	William Adam:
Bill	31/07/2018	PR000721727	8T-3093 Tap	William Adam:
Bill	31/07/2018	PR000721727	116-315 Stud	William Adam:
Bill	10/08/2018	PR000722672	9X-3265 *Seal-Connector 24	William Adam:
Bill	10/08/2018	PR000722671	9X-3490 *Seal	William Adam:
Bill	10/08/2018	PR000722671	9X-3265 *Seal-Connector 24	William Adam:
Credit	13/08/2018	CR140011656	10R-3667 Core Return PR14	William Adam:
Bill	13/08/2018	PR000722789	4D-0306 *Gasket	William Adam:
Bill	13/08/2018	PR000722789	5T-9093 Gage-Oil	William Adam:
Bill	13/08/2018	SR0000069907	Transport Transmission	William Adam:
Bill	13/08/2018	SR0000069907	0L-1026 Plug	William Adam:
Bill	13/08/2018	SR0000069907	0R-8040 Pump GP Gear	William Adam:
Bill	13/08/2018	SR0000069907	Core Deposit	William Adam:
Bill	13/08/2018	SR0000069907	Core Return	William Adam:
Bill	13/08/2018	SR0000069907	0S-1585 Cap Screw	William Adam:
Bill	13/08/2018	SR0000069907	0S-1590 Bolt 3/8 - 16x2-IN	William Adam:
Bill	13/08/2018	SR0000069907	0S-1594 Cap Screw	William Adam:
Bill	13/08/2018	SR0000069907	1M-3937 Ring	William Adam:
Bill	13/08/2018	SR0000069907	1M-4169 Ring	William Adam:
Bill	13/08/2018	SR0000069907	1P-8199 Gasket	William Adam:
Bill	13/08/2018	SR0000069907	1P-9261 Ring	William Adam:
Bill	13/08/2018	SR0000069907	1T-0069 ring	William Adam:
Bill	13/08/2018	SR0000069907	1T-0532 Bearing	William Adam:
Bill	13/08/2018	SR0000069907	1T-0738 Washer	William Adam:
Bill	13/08/2018	SR0000069907	1T-0968 Race	William Adam:
Bill	13/08/2018	SR0000069907	1T-1341 Ring-Seal	William Adam:
Bill	13/08/2018	SR0000069907	2H-2665 Seal	William Adam:
Bill	13/08/2018	SR0000069907	2H3928 Seal	William Adam:
Bill	13/08/2018	SR0000069907	2H-9192 Bearing	William Adam:
Bill	13/08/2018	SR0000069907	2J-6356 Ring-Lock	William Adam:
Bill	13/08/2018	SR0000069907	2K-8257 Seal	William Adam:
Bill	13/08/2018	SR0000069907	2M-4453 Seal O-Ring	William Adam:
Bill	13/08/2018	SR0000069907	3J-1907 Seal	William Adam:
Bill	13/08/2018	SR0000069907	3P-2768 Piston	William Adam:
Bill	13/08/2018	SR0000069907	3P-2792 Seal Ring	William Adam:
Bill	13/08/2018	SR0000069907	3S-0036 Plug	William Adam:

Bill	13/08/2018	SR0000069907	3S-6924 Ring	William Adam:
Bill	13/08/2018	SR0000069907	4H-2494 Sleeve	William Adam:
Bill	13/08/2018	SR0000069907	4K-8603 Plug	William Adam:
Bill	13/08/2018	SR0000069907	4N-8626 Race	William Adam:
Bill	13/08/2018	SR0000069907	5B-3718 Seal	William Adam:
Bill	13/08/2018	SR0000069907	5F-1678 Seal	William Adam:
Bill	13/08/2018	SR0000069907	5H-5312 Roller A	William Adam:
Bill	13/08/2018	SR0000069907	5K-1770 Seal O Ring	William Adam:
Bill	13/08/2018	SR0000069907	5K-9107 Bolt	William Adam:
Bill	13/08/2018	SR0000069907	5L-1100 Bearing	William Adam:
Bill	13/08/2018	SR0000069907	5M-2051 Bearing A	William Adam:
Bill	13/08/2018	SR0000069907	5M-2894 Washer-Hard 10.2)	William Adam:
Bill	13/08/2018	SR0000069907	5R-7137 Washer	William Adam:
Bill	13/08/2018	SR0000069907	6D-4733 Gasket	William Adam:
Bill	13/08/2018	SR0000069907	6I-9255 Disc-Friction	William Adam:
Bill	13/08/2018	SR0000069907	6K-4936 Bolt	William Adam:
Bill	13/08/2018	SR0000069907	6T-9222 Spool	William Adam:
Bill	13/08/2018	SR0000069907	6V-3965 Nipple A	William Adam:
Bill	13/08/2018	SR0000069907	6Y-5793 Ring Seal	William Adam:
Bill	13/08/2018	SR0000069907	7B-3235 Cap Screw	William Adam:
Bill	13/08/2018	SR0000069907	7F-8268 Seal O Ring	William Adam:
Bill	13/08/2018	SR0000069907	7G-7145 Shim Pack Include:	William Adam:
Bill	13/08/2018	SR0000069907	7J-2036 Seal O Ring	William Adam:
Bill	13/08/2018	SR0000069907	7M-2082 Gasket	William Adam:
Bill	13/08/2018	SR0000069907	8B-9777 Gasket	William Adam:
Bill	13/08/2018	SR0000069907	8C-9648 Mount	William Adam:
Bill	13/08/2018	SR0000069907	8E-2477 Disc-Friction	William Adam:
Bill	13/08/2018	SR0000069907	8L-6565 Pin	William Adam:
Bill	13/08/2018	SR0000069907	8M-4431 Seal-O-Ring	William Adam:
Bill	13/08/2018	SR0000069907	8M-4437 Seal O Rin	William Adam:
Bill	13/08/2018	SR0000069907	8M-5010 Seal O Rin	William Adam:
Bill	13/08/2018	SR0000069907	8M-5254 Seal O Rin	William Adam:
Bill	13/08/2018	SR0000069907	8M-8157 Seal O Ring	William Adam:
Bill	13/08/2018	SR0000069907	8M-8281 Seal O Ring	William Adam:
Bill	13/08/2018	SR0000069907	8M-8514 Seal O Ring	William Adam:
Bill	13/08/2018	SR0000069907	8M-8544 Seal O Ring	William Adam:
Bill	13/08/2018	SR0000069907	8M-8597 Spring	William Adam:
Bill	13/08/2018	SR0000069907	8M-8621 Gasket	William Adam:
Bill	13/08/2018	SR0000069907	8P-8744 Ring-Seal	William Adam:
Bill	13/08/2018	SR0000069907	8P-9569 Ring-Seal	William Adam:
Bill	13/08/2018	SR0000069907	8S-3370 Ring	William Adam:
Bill	13/08/2018	SR0000069907	8S-5575 Seal	William Adam:
Bill	13/08/2018	SR0000069907	9F-5940 Gasket	William Adam:
Bill	13/08/2018	SR0000069907	9G-0317 Plate	William Adam:
Bill	13/08/2018	SR0000069907	9G-0333 Seal-Ring	William Adam:
Bill	13/08/2018	SR0000069907	9G-0334 Ring	William Adam:
Bill	13/08/2018	SR0000069907	9G-0335 Ring	William Adam:
Bill	13/08/2018	SR0000069907	9G-0955 Housing A	William Adam:
Bill	13/08/2018	SR0000069907	9H-0223 Seal	William Adam:
Bill	13/08/2018	SR0000069907	9H-2367 Spring	William Adam:
Bill	13/08/2018	SR0000069907	9M-1503 Ring	William Adam:
Bill	13/08/2018	SR0000069907	9M-6974 Gasket	William Adam:
Bill	13/08/2018	SR0000069907	9M-7539 Seal O Ring	William Adam:
Bill	13/08/2018	SR0000069907	9P-4253 Disc A	William Adam:
Bill	13/08/2018	SR0000069907	9W-1398 Bolt-Special 5/16-	William Adam:
Bill	13/08/2018	SR0000069907	9W-2021 Bearing	William Adam:

Bill	13/08/2018	SR0000069907	9X-0941 Nut	William Adam:
Bill	13/08/2018	SR0000069907	030-8535 Bolt	William Adam:
Bill	13/08/2018	SR0000069907	10R-8447 Plate Clutch	William Adam:
Bill	13/08/2018	SR0000069907	Core Deposit	William Adam:
Bill	13/08/2018	SR0000069907	102-8671 Disc	William Adam:
Bill	13/08/2018	SR0000069907	107-3116 Seal O Ring	William Adam:
Bill	13/08/2018	SR0000069907	131-8194 Harness A.	William Adam:
Bill	13/08/2018	SR0000069907	133-2199 Spring	William Adam:
Bill	13/08/2018	SR0000069907	153-4906 Seal-O-Ring	William Adam:
Bill	13/08/2018	SR0000069907	158-0507 Diaphragm	William Adam:
Bill	13/08/2018	SR0000069907	175-7895 Seal-O-Ring	William Adam:
Bill	13/08/2018	SR0000069907	214-4040 Valve GP-SOL	William Adam:
Bill	13/08/2018	SR0000069907	214-7566 Seal-O-Ring	William Adam:
Bill	13/08/2018	SR0000069907	214-7568 Seal-O-Ring	William Adam:
Bill	13/08/2018	SR0000069907	216-0273 Seal-Lip Typ	William Adam:
Bill	13/08/2018	SR0000069907	228-4947 Seal-O-Ring	William Adam:
Bill	13/08/2018	SR0000069907	238-5078 Seal-O-Ring	William Adam:
Bill	13/08/2018	SR0000069907	238-5082 Seal-O-Ring	William Adam:
Bill	13/08/2018	SR0000069907	238-5084 Seal-O-Ring	William Adam:
Bill	13/08/2018	SR0000069907	296-3423 Sensor GP-PO	William Adam:
Bill	13/08/2018	SR0000069907	302-3813 Valve GP-SOL	William Adam:
Bill	13/08/2018	SR0000069907	330-3517 Seal-O-ring	William Adam:
Bill	13/08/2018	SR0000069907	343-4464 Element - XSMN	William Adam:
Bill	13/08/2018	SR0000069907	370-8592 Plate-Clutch	William Adam:
Bill	13/08/2018	SR0000069907	453-4390 Kit DT Gaske	William Adam:
Bill	13/08/2018	SR0000069907	453-8416 Kit DT Beari	William Adam:
Bill	13/08/2018	SR0000069907	5WA1804 Flex Gasket Make	William Adam:
Bill	13/08/2018	SR0000069907	Salvage	William Adam:
Bill	13/08/2018	SR0000069907	Paint CAT Yellow	William Adam:
Bill	13/08/2018	SR0000069907	Emergency Serv Fee	William Adam:
Bill	13/08/2018	SR0000069907	Emergency Frt Pts	William Adam:
Bill	13/08/2018	SR0000069907	PTS Cr Fee Cred	William Adam:
Bill	13/08/2018	SR0000069907	7X-7852 TDTO 10W 20L	William Adam:
Bill	13/08/2018	SR0000069907	Enviro/Consum	William Adam:
Bill	13/08/2018	SR0000069907	FR Labour	William Adam:
Bill	13/08/2018	SR0000069907	FR LABour	William Adam:
Bill	14/08/2018	PR000722905	4D-0307 Cap	William Adam:
Bill	15/08/2018	PR140097729	8T-7338 Bolt	William Adam:
Bill	05/09/2018	PR000724967	20R-2284 Inj GP Fuel	William Adam:
Bill	05/09/2018	PR000724967	20R-2284 Core Deposit	William Adam:
Bill	05/09/2018	PR000724967	230-3728 *Seal	William Adam:
Bill	05/09/2018	PR000724967	230-3775 *Seal	William Adam:
Bill	05/09/2018	PR000724967	9X-7317 *Seal O Ring	William Adam:
Bill	05/09/2018	PR000724967	8S-9191 Bolt	William Adam:
Bill	17/09/2018	PR000725985	3J-1907 *Seal	William Adam:
Bill	17/09/2018	PR000725985	6V-8397 *Seal	William Adam:
Bill	17/09/2018	PR000725985	5P-1076 Washer	William Adam:
Bill	17/09/2018	PR000725985	6C-3241 Bolt	William Adam:
Bill	17/09/2018	PR000725985	4J-5477 *Seal O Ring	William Adam:
Bill	17/09/2018	PR000725985	3J-7354 *Seal O Ring	William Adam:
Bill	17/09/2018	PR000725985	6V-8398 *Seal O Ring	William Adam:
Bill	17/09/2018	PR000725985	3K-0360 *Seal-O-Ring Type:	William Adam:
Bill	17/09/2018	PR000725985	1P-3703 *Seal	William Adam:
Bill	17/09/2018	PR000725985	1P-3704 *Seal	William Adam:
Bill	17/09/2018	PR000725985	4J-0520 *Seal-O-Ring	William Adam:
Bill	17/09/2018	PR000725985	4J-0522 *Seal-O-Ring	William Adam:

Bill	17/09/2018	PR000725985	4J-0524 *Seal-O-Ring	William Adam:
Bill	17/09/2018	PR000725985	4J-5140 *Seal O Ring	William Adam:
Bill	25/09/2018	PR000726755	2D-2444 *Seal	William Adam:
Bill	27/09/2018	PR000727045	2D-2444 *Seal	William Adam:
Bill	09/10/2018	PR140098995	3E-9901 *DEO-CG4-PK5L	William Adam:
Bill	10/10/2018	PR140099032	234-2592 *Kit-Seal-H.C	William Adam:
Bill	10/10/2018	PR140099031	5WA1448 Tape Elect 19MM	William Adam:
Bill	18/10/2018	PR140099218	7K-9589 BRG Sleeve	William Adam:
Bill	18/10/2018	PR140099216	3E-9901 *DEO-CG4-PK5L	William Adam:
Bill	24/10/2018	PR140099349	456-8471 *Hose BK	William Adam:
Bill	24/10/2018	PR140099348	456-8471 *Hose BK	William Adam:
Bill	24/10/2018	PR140099348	4J-0522 *Seal-O-Ring	William Adam:
Bill	24/10/2018	PR140099348	309-6942 *Hydo Adv 20Lit D	William Adam:
Bill	24/10/2018	PR140099348	Hose Assy Lab	William Adam:
Bill	29/10/2018	PR140099429	Emergency Service Fee	William Adam:
Credit	29/10/2018	CR000064961	20R-2284 Core Return	William Adam:
Bill	29/10/2018	PR140099428	Emergency Service Fee	William Adam:
Bill	30/10/2018	PR140099446	455-1125 Base AS-Joys	William Adam:
Bill	02/11/2018	PR140099515	230-7654 Harness AS	William Adam:
Bill	02/11/2018	PR140099515	342-2410 Valve GP - SOL	William Adam:
Bill	05/11/2018	PR140099563	392 - 6383 Kit Shock	William Adam:
Bill	05/11/2018	PR140099562	230-7654 Harness AS	William Adam:
Bill	09/11/2018	PR140099651	222-0345 Belt GP Seat	William Adam:
Credit Card Charge	12/11/2018	42468	GME Plug (OL2595)	Mildura 4WD
Credit Card Charge	12/11/2018	42468	GME2 Pin Lead	Mildura 4WD
Bill	14/11/2018	PR050150303	9X-3401 Pin	William Adam:
Bill	14/11/2018	PR050150303	9x-3402 socket	William Adam:
Bill	14/11/2018	PR050150303	155-2270 plug	William Adam:
Bill	14/11/2018	PR050150303	102-8802 recptable	William Adam:
Bill	15/11/2018	PR050150337	9L-1775 Bracket Type	William Adam:
Bill	16/11/2018	PR050150371	7T-0266 Bracket A	William Adam:
Bill	16/11/2018	PR050150371	9L-6331 Bracket	William Adam:
Bill	16/11/2018	PR050150371	341-7982 Harness AS	William Adam:
Bill	20/11/2018	PR050150438	471-8197 Receiver	William Adam:
Bill	17/01/2019	PR140100743	376-9017 *Kit-Seal-H.C	William Adam:
Bill	18/01/2019	PR140100770	5P-5846 *Seal O Ring	William Adam:
Bill	18/01/2019	PR140100770	5P-8068 *Seal-O-Ring	William Adam:
Bill	22/01/2019	PR140100845	238-8665 *Switch AS-PR	William Adam:
Bill	19/02/2019	PR000739716	9G-2758 Lockout Swit	William Adam:
Bill	19/02/2019	PR000739716	452-6892 *Switch GP-Discor	William Adam:
Bill	19/02/2019	PR000739716	7X-0291 Bolt	William Adam:
Bill	20/02/2019	PR000739842	1P-1210 Washer	William Adam:
Bill	25/02/2019	PR140101475	6L-5359 *Seal O Ring	William Adam:
Bill	25/02/2019	PR140101475	1B-3953 Bearing-Cone	William Adam:
Bill	25/02/2019	PR140101475	1B-3955 Cup	William Adam:
Bill	25/02/2019	PR140101475	3J-4776 *Seal	William Adam:
Bill	25/02/2019	PR140101475	8W-4517 Retainer	William Adam:
Bill	25/02/2019	PR140101475	8T-9398 Bolt	William Adam:
Bill	25/02/2019	PR140101475	144-7291 *Gasket	William Adam:
Bill	25/02/2019	PR140101474	6V-5188 *Seal	William Adam:
Bill	25/02/2019	PR140101474	1B-3955 Cup	William Adam:
Bill	25/02/2019	PR140101474	3J-4776 *Seal	William Adam:
Bill	28/02/2019	PR000740674	326-1006 Kit-Pump	William Adam:
Bill	01/03/2019	PR140101576	228-5897 Bolt-Torx M8x1.25	William Adam:
Bill	01/03/2019	PR140101575	6V-8398 *Seal O Ring	William Adam:
Bill	01/03/2019	PR140101575	6V-8397 *Seal	William Adam:

Bill	19/03/2019	PR140101935	096-4034 Bolt-Wing M6X1X'	William Adam:
Bill	19/03/2019	PR140101935	5T-9093 GAGE-Oil	William Adam:
Bill	19/03/2019	INV-0312	Cap FF O Ring	N.E Mechanic:
Bill	19/03/2019	INV-0312	Plug FF O Ring	N.E Mechanic:
Bill	19/03/2019	INV-0312	Cap Nut 1-1/16 JIC	N.E Mechanic:
Bill	29/03/2019	PR140102153	330-0663 *Belt	William Adam:
Bill	29/03/2019	PR140102154	342-7204 Clip-Loop	William Adam:
Bill	29/03/2019	PR140102154	330-0663 *Belt	William Adam:
Bill	02/04/2019	PR140102209	165-5970 Switch GP-Toggle	William Adam:
Bill	03/04/2019	73509100001	LED Beacon Amber Lens	Ashdown Ingr:
Bill	08/04/2019	PR140102330	125-1302 *Switch AS	William Adam:
Bill	10/04/2019	PR140102387	3E-5239 Relay A	William Adam:
Bill	10/04/2019	PR140102387	6T-3642 Breaker	William Adam:
Bill	10/04/2019	PR140102387	6T-3643 Circuit Breaker	William Adam:
Bill	10/04/2019	PR140102385	173-7035 Block Kit-SL	William Adam:
Bill	11/04/2019	pr140102425	171-2205 CONT GP-XMSN	William Adam:
Bill	11/04/2019	PR140102423	175-5059 ROLLER KIT	William Adam:
Bill	11/04/2019	PR140102423	186-2098 FASTENER KIT	William Adam:
Bill	12/04/2019	PR140102465	186-2098 FASTENER KIT	William Adam:
Bill	12/04/2019	PR140102467	205-5399 HARNESS AS	William Adam:
Bill	15/04/2019	PR140102494	200-5335 COVER	William Adam:
Bill	16/04/2019	PR140102523	9P-2369 JET A	William Adam:
Bill	16/04/2019	PR140102523	8T-2901 JET A	William Adam:
Bill	16/04/2019	PR140102523	3E-5239 RELAY A	William Adam:
Bill	16/04/2019	PR140102523	6T-3642 BREAKER	William Adam:
Bill	16/04/2019	PR140102523	6T-3643 CIRCUIT BRKR	William Adam:
Credit Card Charge	23/04/2019	91	Wedge globes	Daryl Robertsc
Credit Card Charge	23/04/2019	00022019	Adaptor and mini nut UHF	Horsham Auto
Bill	24/04/2019	INV-0328	Hi Coupler Female 1/4	N.E Mechanic:
Bill	24/04/2019	INV-0328	BALL VALVE 1/4' BSPP 2W	N.E Mechanic:
Bill	24/04/2019	INV-0328	SPIRAL GUARD 40MM BLA	N.E Mechanic:
Bill	26/04/2019	SR050020513	TROUBLESHOOT ENGINE	William Adam:
Bill	30/04/2019	PR050153693	326-1006 KIT-PUMP	William Adam:
Bill	01/05/2019	PR050153723	324-05843 HARNESS AS	William Adam:
Bill	01/05/2019	PR050153723	8M-4988 SEAL O RIN	William Adam:
Bill	02/05/2019	PR050153760	338-1462 SENSOR GP-PO	William Adam:
Bill	06/05/2019	PR050153816	1B-3953 BEARING CONE	William Adam:
Bill	06/05/2019	PR050153816	1B-3955 CUP	William Adam:
Bill	06/05/2019	PR050153816	3J-4776 SEAL	William Adam:
Bill	06/05/2019	PR050153816	144-7291 GASKET	William Adam:
Bill	30/05/2019	SR050020672	Troubleshoot Engine, Servic	William Adam:
Bill	03/06/2019	PR140103406	1A-1135 CAPSCREW	William Adam:
Bill	03/06/2019	PR140103406	3B-6753 CAP SCREW	William Adam:
Bill	03/06/2019	PR140103406	4D-1577 SEAL O RING	William Adam:
Bill	03/06/2019	PR140103406	ESF	William Adam:
Bill	03/06/2019	PR140103409	170-7709 SWITCH A	William Adam:
Bill	03/06/2019	PR140103407	396-0664 CAP BRG YM	William Adam:
Bill	03/06/2019	PR140103407	9J-8323 TRUNNION	William Adam:
Bill	03/06/2019	PR140103407	361-1713 TRUNNION -YM	William Adam:
Bill	17/06/2019	SR050020723	Reseal Brake Actuator	William Adam:
Bill	24/06/2019	PR140103789	326-0610 Latch AS	William Adam:
Bill	24/06/2019	PR140103789	305-3155 Pawl	William Adam:
Bill	26/06/2019	PR140103857	4D-0307 Cap	William Adam:
Bill	26/06/2019	PR140103857	4D-0306 Gasket	William Adam:
Bill	01/07/2019	INV-0339	1" Code 61 O Ring Flange P	N.E Mechanic:
Bill	01/07/2019	INV-0339	1 1/4" Code 61 O Ring Flang	N.E Mechanic:

Bill	01/07/2019	INV-0339	Adaptor Female 3/8	N.E Mechanic:
Bill	01/07/2019	INV-0339	Nipple 3/8 x 1/4 NPT	N.E Mechanic:
Bill	01/07/2019	INV-0339	Hose Strap 1.5M Tydee Car	N.E Mechanic:
Bill	01/07/2019	INV-0339	Reducing Bush 1/2 x 3/8 NP	N.E Mechanic:
Bill	02/07/2019	PR140103964	10R-0484 Pump GP WTR	William Adam:
Bill	02/07/2019	PR140103964	10R-0484 Core Deposit	William Adam:
Bill	02/07/2019	PR140103964	4P-2383 Adapter	William Adam:
Bill	02/07/2019	PR140103964	171-4358 Seal-O-Ring	William Adam:
Bill	02/07/2019	PR140103964	341-1429 Seal-PIP	William Adam:
Bill	02/07/2019	PR140103964	167-4407 Seal-O-Ring	William Adam:
Bill	02/07/2019	PR140103964	371-8946 CM Hose Bulk	William Adam:
Bill	02/07/2019	PR140103965	349-1533 Kit-Gasket (W	William Adam:
Bill	02/07/2019	PR140103965	228-0509 Hose	William Adam:
Bill	08/07/2019	PR140104063	9W-9930 Mount AS	William Adam:
Bill	08/07/2019	PR140104063	5P-1086 Seal	William Adam:
Bill	08/07/2019	PR140104063	9F-7283 Ring	William Adam:
Bill	08/07/2019	PR140104063	5P-1717 Clamp	William Adam:
Bill	08/07/2019	PR140104064	6Y-2065 Mount AS	William Adam:
Bill	08/07/2019	PR140104064	294-9707 Hose	William Adam:
Bill	09/07/2019	PR140104076	6D-9877 YOKE AS	William Adam:
Bill	09/07/2019	PR140104080	209-4579 Clamp-T'Bolt	William Adam:
Bill	09/07/2019	PR140104080	209-4573 Clamp-T'Bolt	William Adam:
Bill	09/07/2019	PR140104081	209-4573 Clamp-T'Bolt	William Adam:
Bill	09/07/2019	PR140104081	236-8761 Muffler	William Adam:
Bill	12/07/2019	PR140104163	Repairs & Maintenance - SC	William Adam:
Bill	15/07/2019	PR140104182	Plant Hire - SC09 CAT 627C	William Adam:
Credit	16/07/2019	CR140012168	10R-0484 Core Return	William Adam:
Bill	26/07/2019	PR140104403	161-1705 Sensor GP	William Adam:
Bill	06/08/2019	INV-.272	Repairs & Maintenance - SC	N.E Mechanic:
Bill	08/08/2019	INV-35901	Repair 2 x Bores On Scrape	TBAS Precisis
Bill	14/08/2019	PR140104683	4D-0306 Gasket	William Adam:
Bill	15/08/2019	PR140104702	5H-7844 Gasket	William Adam:
Bill	16/08/2019	PR140104719	272-2983 Cap-Filter	William Adam:
Bill	16/08/2019	PR140104725	125-1302 Switch AS	William Adam:
Bill	19/08/2019	PR140104763	243-0769 Switch AS-RO	William Adam:
Bill	27/08/2019	PR000756701	3E-3535 Dryer	William Adam:
Bill	27/08/2019	PR000756701	187-8661 Fitting As-AIR Cor	William Adam:
Bill	27/08/2019	PR000756701	3E-4066 Fitting A	William Adam:
Bill	29/08/2019	PR000756931	354-8832 Kit-Seal	William Adam:
Bill	29/08/2019	PR000756930	354-8832 Kit-Seal	William Adam:
Bill	29/08/2019	PR000756930	4N-9679 Governor A	William Adam:
Bill	30/08/2019	PR140104942	190-3850 Core	William Adam:
Bill	30/08/2019	PR140104966	222-2367 Valve AS-GAS	William Adam:
Bill	30/08/2019	PR140104966	190-3850 Core	William Adam:
Bill	02/09/2019	PR140104997	222-2367 Valve AS-GAS	William Adam:
Bill	02/09/2019	PR140104997	190-3850 Core	William Adam:
Bill	05/09/2019	PR140105141	398-0940 Switch AS-MA	William Adam:
Bill	17/09/2019	PR140105366	267-7539 Belt	William Adam:
Bill	10/10/2019	323839	Roller	ITR Victoria
Bill	21/10/2019	PR140105936	5P-5680 M Seal STK	William Adam:
Bill	21/10/2019	PR140105936	5P-6605 M Seal STK	William Adam:
Bill	22/10/2019	PR140105958	8X-6686 Window	William Adam:
Bill	22/10/2019	PR140105958	5P-5680 M Seal STK	William Adam:
Bill	22/10/2019	PR140105959	102-2882 Glass	William Adam:
Bill	22/10/2019	PR140105960	5P-5680 M Seal STK	William Adam:
Bill	29/11/2019	PR140106661	112-6174 Switch AS Rotary	William Adam:

Bill	29/11/2019	PR140106661	8N-4617 Clamp Kit	William Adam:
Bill	29/11/2019	PR140106661	204-2581 Valve AS	William Adam:
Bill	29/11/2019	PR140106660	254-9168 Hose A	William Adam:
Bill	29/11/2019	PR140106658	102-2882 Glass	William Adam:
Bill	06/12/2019	PR140106805	8H-7521 Seal O Ring	William Adam:
Bill	06/12/2019	PR140106805	4D-0306 Gasket	William Adam:
Bill	09/12/2019	AI102946	623F Wheel Hub	DGI Trading (/
Bill	10/12/2019	PR140106831	4D-0307 Cap	William Adam:
Bill	10/12/2019	PR140106872	252-5805 Vent AS	William Adam:
Bill	19/12/2019	PR140107053	1P-9593 Cone	William Adam:
Bill	19/12/2019	PR140107053	1P-95594 Cup	William Adam:
Bill	19/12/2019	PR140107053	2P-1823 Cup	William Adam:
Bill	19/12/2019	PR140107053	2P-1824 Cone	William Adam:
Bill	19/12/2019	PR140107052	6G-8370 *SHIM PAC	William Adam:
Bill	19/12/2019	PR140107052	9G-5319 *SEAL G	William Adam:
Bill	19/12/2019	PR140107052	1A-8537 CAPSCRE	William Adam:
Bill	19/12/2019	PR140107052	1M-9015 *SEAL-O-R	William Adam:
Bill	19/12/2019	PR140107052	2D-2444 *SEAL	William Adam:
Bill	19/12/2019	PR140107052	3D-8422 *SEAL O R	William Adam:
Bill	19/12/2019	PR140107052	3K-0360 *SEAL-O-R	William Adam:
Bill	19/12/2019	PR140107052	4D-1577 *SEAL O R	William Adam:
Bill	19/12/2019	PR140107052	6F-4855 *SEAL	William Adam:
Bill	23/01/2020	PR0000769987	20R-8064 Injector G-F	William Adam:
Bill	23/01/2020	PR0000769987	20R-8064 Core Deposit	William Adam:
Bill	23/01/2020	PR0000769987	235-9651 Bolt-Socket	William Adam:
Bill	30/01/2020	PR140107536	204-8976 Pan As Flat	William Adam:
Bill	03/02/2020	PR140107594	5T-2180 Cylinder A	William Adam:
Bill	03/02/2020	PR140107594	6K-1807 Diaphragm	William Adam:
Bill	03/02/2020	PR140107594	6K-2643 Boot	William Adam:
Bill	03/02/2020	PR140107594	187-0424 Actuator KT	William Adam:
Bill	03/02/2020	PR140107594	6K-1805 Clamp A	William Adam:
Credit	06/02/2020	CR000067936	20R-8064 Core Return	William Adam:
Bill	07/02/2020	PR140107697	5T-2180 Cylinder A	William Adam:
Bill	07/02/2020	PR140107696	187-0424 Actuator KT	William Adam:
Bill	07/02/2020	PR140107696	6K-1807 Diaphragm	William Adam:
Bill	07/02/2020	PR140107696	6K-2643 Boot	William Adam:
Bill	01/04/2020	PR140108699	8W-0265 TUBE A	William Adam:
Bill	01/04/2020	PR140108699	5T-9093 GAGE-OIL	William Adam:
Bill	01/04/2020	PR140108699	4D-0307 CAP	William Adam:
Bill	01/04/2020	PR140108699	4D-0306 *GASKET	William Adam:
Bill	01/04/2020	PR140108699	201-6615 *SENSOR GP-SP	William Adam:
Bill	02/04/2020	PR140108729	172-6062 PLUG AS-CONN	William Adam:
Bill	02/04/2020	PR140108729	435-4789 BREATHER-YM	William Adam:
Bill	02/04/2020	PR140108729	7F-7782 RETAINER	William Adam:
Bill	02/04/2020	PR140108729	7F-7783 SPRING	William Adam:
Bill	02/04/2020	PR140108729	196-7559 DRUM AS-BRAK	William Adam:
Bill	02/04/2020	PR140108729	2D-0626 *SEAL	William Adam:
Bill	02/04/2020	PR140108729	2F-6066 *RING	William Adam:
Bill	02/04/2020	PR140108729	5F-2830 BEARING	William Adam:
Bill	02/04/2020	PR140108729	7F-7781 WASHER	William Adam:
Bill	02/04/2020	PR140108729	9H-8839 *SEAL	William Adam:
Bill	02/04/2020	PR140108729	5P-6628 WIRE-LOCK	William Adam:
Bill	02/04/2020	PR140108729	3J-9173 BOLT	William Adam:
Bill	02/04/2020	PR140108729	10R-3399 SHOE AS	William Adam:
Bill	02/04/2020	PR140108729	10R-3399 CORE DEPOSIT	William Adam:
Bill	02/04/2020	PR140108729	9G-5319 *SEAL G	William Adam:

Bill	02/04/2020	PR140108729	1M-9015 *SEAL-O-RIN	William Adam:
Bill	02/04/2020	PR140108729	2D-2444 *SEAL	William Adam:
Bill	02/04/2020	PR140108729	3D-8422 *SEAL O RING	William Adam:
Bill	02/04/2020	PR140108729	4D-1577 *SEAL O RING	William Adam:
Bill	03/04/2020	PR140108759	236-7769 ROLLER	William Adam:
Bill	06/04/2020	PR140108778	5P-9949 BEARING	William Adam:
Bill	08/04/2020	PR140108831	341-4938 *BELT	William Adam:
Bill	08/04/2020	PR140108831	9X-3490 *SEAL	William Adam:
Bill	08/04/2020	PR140108831	9X-5615 *SEAL	William Adam:
Credit	21/04/2020	CR140012546	10R-3399 CORE RETURN	William Adam:
Bill	29/04/2020	PR0000778471	114-0918 VALVE A	William Adam:
Bill	29/04/2020	PR0000778472	20R-8064 INJECTOF	William Adam:
Bill	29/04/2020	PR0000778472	20R-8064 CORE DE	William Adam:
Bill	29/04/2020	PR0000778472	235-9651 BOLT-SOC	William Adam:
Bill	29/04/2020	PR0000778472	149-5240 *INJECTOF	William Adam:
Bill	29/04/2020	PR0000778472	293-0730 *RING-BAC	William Adam:
Bill	29/04/2020	PR0000778472	109-3207 *INJECTOF	William Adam:
Bill	29/04/2020	PR0000778472	148-2903 *INJECTOF	William Adam:
Bill	29/04/2020	PR0000778472	258-2829 BREATHE	William Adam:
Bill	30/04/2020	1462956	VALVE-R12 HORIZONTAL I	Mildura Truck
Credit	30/04/2020	CR000068447	20R-8064 CORE RETURN	William Adam:
Bill	12/05/2020	PR140109462	230-6368 *BATTERY	William Adam:
Bill	25/05/2020	PR140109817	161-1703 *SENSOR	William Adam:
Bill	27/05/2020	PR140109883	439-3940 BRACKET AS 2	William Adam:
Bill	15/06/2020	PR140110325	8T-4136 BOLT	William Adam:
Bill	15/06/2020	PR140110325	8T-4195 BOLT	William Adam:
Bill	15/06/2020	PR140110325	183-7121 BOLT	William Adam:
Bill	15/06/2020	PR140110325	5P-2817 *CM-HOSE STK	William Adam:
Bill	15/06/2020	PR140110325	4P-7581 CLIP	William Adam:
Bill	15/06/2020	PR140110325	4P-8134 CLIP	William Adam:
Bill	15/06/2020	PR140110325	361-1713 TRUNNION-YM	William Adam:
Bill	15/06/2020	PR140110325	396-0664 CAP-BRG-YM	William Adam:
Bill	15/06/2020	PR140110325	8T-8925 BOLT	William Adam:
Bill	15/06/2020	PR140110325	5S-9062 SPACER	William Adam:
Bill	15/06/2020	PR140110325	6V-9748 *SEAL	William Adam:
Bill	15/06/2020	PR140110325	8T-5092 BOLT	William Adam:
Bill	15/06/2020	PR140110325	4W-1203 CUP	William Adam:
Bill	15/06/2020	PR140110325	4W-1204 CONE	William Adam:
Bill	15/06/2020	PR140110325	6V-1820 BOLT	William Adam:
Bill	15/06/2020	PR140110325	200-2258 *GASKET	William Adam:
Bill	15/06/2020	PR140110325	371-8946 *CM HOSE BULK	William Adam:
Bill	15/06/2020	PR140110325	209-4573 CLAMP-T'BOLT	William Adam:
Bill	15/06/2020	PR140110325	371-8094 *CM HOSE BULK	William Adam:
Bill	15/06/2020	PR140110325	423-1980 *IN HOSE-BULK	William Adam:
Bill	15/06/2020	PR140110325	111-7092 *HOSE	William Adam:
Bill	15/06/2020	PR140110325	209-4578 CLAMP-T'BOLT	William Adam:
Bill	15/06/2020	PR140110325	388-7016 CLAMP-BENT B	William Adam:
Bill	15/06/2020	PR140110325	148-6870 *HOSE AS	William Adam:
Bill	15/06/2020	PR140110325	159-0225 *HOSE AS	William Adam:
Bill	15/06/2020	PR140110325	321-7076 *HOSE AS.	William Adam:
Bill	15/06/2020	PR140110325	8M-5010 *SEAL O RIN	William Adam:
Bill	15/06/2020	PR140110325	8M-4987 *SEAL O RING	William Adam:
Bill	15/06/2020	PR140110325	8M-8281 *SEAL O RING	William Adam:
Bill	15/06/2020	PR140110325	9M-7539 *SEAL O RING	William Adam:
Bill	15/06/2020	PR140110325	4D-0307 CAP	William Adam:
Bill	15/06/2020	PR140110325	4D-0306 *GASKET	William Adam:

Bill	15/06/2020	PR140110325	5H-7844 *GASKET	William Adam:
Bill	15/06/2020	PR140110325	2S-4071 *SEAL-O-RING	William Adam:
Bill	15/06/2020	PR140110325	7D-7111 *SEAL-O-RING	William Adam:
Bill	15/06/2020	PR140110325	216-0273 *SEAL-LIP TYP	William Adam:
Bill	15/06/2020	PR140110325	4D-1577 *SEAL O RING	William Adam:
Bill	15/06/2020	PR140110325	5M-7329 *SEAL O RING	William Adam:
Bill	15/06/2020	PR140110325	330-0663 *BELT	William Adam:
Bill	15/06/2020	PR140110325	330-0662 *BELT	William Adam:
Bill	15/06/2020	PR140110326	7X-0346 BOLT	William Adam:
Bill	15/06/2020	PR140110326	381-2512 PULLEY	William Adam:
Bill	15/06/2020	PR140110326	279-2589 PULLEY AS.	William Adam:
Bill	15/06/2020	PR140110326	381-2509 TENSIONER	William Adam:
Bill	15/06/2020	PR140110326	375-8345 TENSIONER AS	William Adam:
Bill	15/06/2020	PR140110326	7C-8370 CAP	William Adam:
Bill	15/06/2020	PR140110326	160-8742 BOLT-HEX HEA	William Adam:
Bill	15/06/2020	PR140110326	6V-3822 BOLT	William Adam:
Bill	15/06/2020	PR140110326	212-6933 CLAMP-T'BOLT	William Adam:
Bill	15/06/2020	PR140110326	209-4578 CLAMP-T'BOLT	William Adam:
Bill	15/06/2020	PR140110326	421-3152 NUT-HEX	William Adam:
Bill	15/06/2020	PR140110326	421-3183 BOLT-HEX HEA	William Adam:
Bill	15/06/2020	PR140110326	7X-0320 BOLT	William Adam:
Bill	15/06/2020	PR140110326	5T-9093 GAGE-OIL	William Adam:
Bill	15/06/2020	PR140110326	0L-1558 BOLT	William Adam:
Bill	16/06/2020	PR140110375	228-6892 *HARNESS AS	William Adam:
Bill	16/06/2020	PR140110375	228-6973 *HARNESS AS	William Adam:
Bill	16/06/2020	PR140110375	8S-9379 *HOSE	William Adam:
Bill	16/06/2020	PR140110375	106-9858 *HOSE	William Adam:
Bill	16/06/2020	PR140110375	309-4069 *HOSE-HUMP	William Adam:
Bill	16/06/2020	PR140110375	4W-8118 CLAMP	William Adam:
Bill	16/06/2020	PR140110375	299-3398 BOLT HEX	William Adam:
Bill	16/06/2020	PR140110375	215-8029 *HOSE AS.	William Adam:
Bill	16/06/2020	PR140110375	7X-0320 BOLT	William Adam:
Bill	16/06/2020	PR140110375	431-2155 YOKE-YM	William Adam:
Bill	16/06/2020	PR140110375	7S-2945 *GASKET	William Adam:
Bill	16/06/2020	PR140110384	6V-8849 BOLT	William Adam:
Bill	16/06/2020	PR140110384	8T-4994 WASHER	William Adam:
Bill	18/06/2020	PR140110480	134-4040 SPIDER A-FAN	William Adam:
Bill	18/06/2020	inv-37394	Press Out Biushes And Fit N TBAS Precisc	
Bill	19/06/2020	PR140110520	173-0888 UNIV JT AS	William Adam:
Bill	19/06/2020	PR140110516	317-7071 SPACER	William Adam:
Bill	19/06/2020	PR140110516	6V-8513 WASHER-HARD	William Adam:
Bill	19/06/2020	PR140110516	7X-0586 WASHER-HARD 7.	William Adam:
Bill	19/06/2020	PR140110516	9X-8266 WASHER	William Adam:
Bill	19/06/2020	PR140110516	296-7726 STRIKER AS	William Adam:
Bill	19/06/2020	PR140110516	8Y-6378 *SEAL-HANDLE	William Adam:
Bill	19/06/2020	PR140110515	6V-5849 BLADE A	William Adam:
Bill	19/06/2020	PR140110515	6V-5851 BLADE A	William Adam:
Bill	19/06/2020	PR140110515	146-6433 BLADE AS-WIPEF	William Adam:
Bill	19/06/2020	PR140110515	5P-1076 WASHER	William Adam:
Bill	19/06/2020	PR140110515	5P-4116 WASHER	William Adam:
Bill	19/06/2020	PR140110515	7X-7729 WASHER	William Adam:
Bill	19/06/2020	PR140110515	8T-4136 BOLT	William Adam:
Bill	19/06/2020	PR140110515	8T-4137 BOLT	William Adam:
Bill	19/06/2020	PR140110515	8T-4138 BOLT	William Adam:
Bill	19/06/2020	PR140110515	8T-4189 BOLT	William Adam:
Bill	19/06/2020	PR140110515	8T-4195 BOLT	William Adam:

Bill	19/06/2020	PR140110515	8T-0318 *SHIM	William Adam:
Bill	19/06/2020	PR140110515	8T-4183 BOLT	William Adam:
Bill	19/06/2020	PR140110515	361-1691 BRG-SLV-YM	William Adam:
Bill	22/06/2020	PR140110548	145-4212 INDICATOR GP-A	William Adam:
Bill	22/06/2020	PR140110552	7X-0586 WASHER-HARD 7.	William Adam:
Bill	22/06/2020	PR140110552	170-7709 HANDLE AS-PA	William Adam:
Bill	23/06/2020	INV-37412	Machine Holes In Crown Wh	TBAS Precisc
Bill	23/06/2020	PR140110588	0L-2070 CAP SCREW	William Adam:
Bill	23/06/2020	PR140110588	165-3928 BOLT-HEX HEA	William Adam:
Bill	23/06/2020	PR140110588	5P-7213 WASHER	William Adam:
Bill	23/06/2020	PR140110588	1A-0168 CAP SCREW	William Adam:
Bill	23/06/2020	PR140110589	6V-4463 BOLT-LOCKING 1/	William Adam:
Bill	23/06/2020	PR140110589	2D-9191 CONE	William Adam:
Bill	23/06/2020	PR140110587	5M-2894 WASHER-HARD 1	William Adam:
Bill	23/06/2020	PR140110587	0L-2070 CAP SCREW	William Adam:
Bill	23/06/2020	PR140110587	0T-0573 CAP SCREW	William Adam:
Bill	23/06/2020	PR140110587	0S-1594 CAP SCREW	William Adam:
Bill	23/06/2020	PR140110587	0L-1351 CAP SCREW	William Adam:
Bill	23/06/2020	PR140110587	2A-4639 BOLT	William Adam:
Bill	23/06/2020	PR140110587	1C-2251 BOLT	William Adam:
Bill	23/06/2020	PR140110587	0S-0509 CAP SCREW	William Adam:
Bill	23/06/2020	PR140110587	9S-8752 NUT	William Adam:
Bill	23/06/2020	PR140110587	5P-7213 WASHER	William Adam:
Bill	23/06/2020	PR140110587	1A-0168 CAP SCREW	William Adam:
Bill	23/06/2020	PR140110587	1K-6872 *NUT	William Adam:
Bill	23/06/2020	PR140110587	6K-7917 BOLT	William Adam:
Bill	23/06/2020	PR140110587	5P-8245 WASHER-HARD	William Adam:
Bill	23/06/2020	PR140110587	5M-7329 *SEAL O RING	William Adam:
Bill	24/06/2020	PR000783144	2D-9190 CUP	William Adam:
Credit	24/06/2020	CR140012675	6V-8849 BOLT	William Adam:
Credit	24/06/2020	CR140012675	8T-4994 WASHER	William Adam:
Credit	24/06/2020	CR140012674	134-4040 SPIDER A-FAN	William Adam:
Credit	24/06/2020	CR140012676	8T-4136 BOLT	William Adam:
Credit	24/06/2020	CR140012676	8T-4195 BOLT	William Adam:
Credit	24/06/2020	CR140012676	183-7121 BOLT	William Adam:
Credit	24/06/2020	CR140012676	5P-2817 *CM-HOSE STK	William Adam:
Credit	24/06/2020	CR140012676	4P-7581 CLIP	William Adam:
Credit	24/06/2020	CR140012676	4P-8134 CLIP	William Adam:
Credit	24/06/2020	CR140012676	361-1713 TRUNNION-YM	William Adam:
Credit	24/06/2020	CR140012676	396-0664 CAP-BRG-YM	William Adam:
Credit	24/06/2020	CR140012676	8T-8925 BOLT	William Adam:
Credit	24/06/2020	CR140012676	5S-9062 SPACER	William Adam:
Credit	24/06/2020	CR140012676	6V-9748 *SEAL	William Adam:
Credit	24/06/2020	CR140012676	8T-5092 BOLT	William Adam:
Credit	24/06/2020	CR140012676	4W-1203 CUP	William Adam:
Credit	24/06/2020	CR140012676	4W-1204 CONE	William Adam:
Credit	24/06/2020	CR140012676	6V-1820 BOLT	William Adam:
Credit	24/06/2020	CR140012676	200-2258 *GASKET	William Adam:
Credit	24/06/2020	CR140012676	371-8946 *CM HOSE BULK	William Adam:
Credit	24/06/2020	CR140012676	209-4573 CLAMP-T'BOLT	William Adam:
Credit	24/06/2020	CR140012676	371-8094 *CM HOSE BULK	William Adam:
Credit	24/06/2020	CR140012676	423-1980 *IN HOSE-BULK	William Adam:
Credit	24/06/2020	CR140012676	111-7092 *HOSE	William Adam:
Credit	24/06/2020	CR140012676	209-4578 CLAMP-T'BOLT	William Adam:
Credit	24/06/2020	CR140012676	388-7016 CLAMP-BENT B	William Adam:
Credit	24/06/2020	CR140012676	148-6870 *HOSE AS	William Adam:

Credit	24/06/2020	CR140012676	159-0225 *HOSE AS	William Adam:
Credit	24/06/2020	CR140012676	321-7076 *HOSE AS	William Adam:
Credit	24/06/2020	CR140012676	8M-5010 *SEAL O RIN	William Adam:
Credit	24/06/2020	CR140012676	8M-4987 *SEAL O RING	William Adam:
Credit	24/06/2020	CR140012676	8M-8281 *SEAL O RING	William Adam:
Credit	24/06/2020	CR140012676	9M-7539 *SEAL O RING	William Adam:
Credit	24/06/2020	CR140012676	4D-0307 CAP	William Adam:
Credit	24/06/2020	CR140012676	4D-0306 *GASKET	William Adam:
Credit	24/06/2020	CR140012676	5H-7844 *GASKET	William Adam:
Credit	24/06/2020	CR140012676	2S-4071 *SEAL-O-RING	William Adam:
Credit	24/06/2020	CR140012676	7D-7111 *SEAL-O-RING	William Adam:
Credit	24/06/2020	CR140012676	216-0273 *SEAL-LIP TYP	William Adam:
Credit	24/06/2020	CR140012676	4D-1577 *SEAL O RING	William Adam:
Credit	24/06/2020	CR140012676	5M-7329 *SEAL O RING	William Adam:
Credit	24/06/2020	CR140012676	330-0663 *BELT	William Adam:
Credit	24/06/2020	CR140012676	330-0662 *BELT	William Adam:
Credit	24/06/2020	CR140012676	7X-0346 BOLT	William Adam:
Credit	24/06/2020	CR140012676	381-2512 PULLEY	William Adam:
Credit	24/06/2020	CR140012676	279-2589 PULLEY AS.	William Adam:
Credit	24/06/2020	CR140012676	381-2509 TENSIONER	William Adam:
Credit	24/06/2020	CR140012676	375-8345 TENSIONER AS	William Adam:
Credit	24/06/2020	CR140012676	7C-8370 CAP	William Adam:
Credit	24/06/2020	CR140012676	160-8742 BOLT-HEX HEA	William Adam:
Credit	24/06/2020	CR140012676	6V-3822 BOLT	William Adam:
Credit	24/06/2020	CR140012676	212-6933 CLAMP-T*BOLT	William Adam:
Credit	24/06/2020	CR140012676	209-4578 CLAMP-T*BOLT	William Adam:
Credit	24/06/2020	CR140012676	421-3152 NUT-HEX	William Adam:
Credit	24/06/2020	CR140012676	421-3183 BOLT-HEX HEA	William Adam:
Credit	24/06/2020	CR140012676	7X-0320 BOLT	William Adam:
Credit	24/06/2020	CR140012676	5T-9093 GAGE-OIL	William Adam:
Credit	24/06/2020	CR140012676	0L-1558 BOLT	William Adam:
Credit	24/06/2020	CR140012676	228-6892 *HARNESS AS	William Adam:
Credit	24/06/2020	CR140012676	228-6973 *HARNESS AS	William Adam:
Credit	24/06/2020	CR140012676	8S-9379 *HOSE	William Adam:
Credit	24/06/2020	CR140012676	106-9858 *HOSE	William Adam:
Credit	24/06/2020	CR140012676	309-4069 *HOSE-HUMP	William Adam:
Credit	24/06/2020	CR140012676	4W-8118 CLAMP	William Adam:
Credit	24/06/2020	CR140012676	299-3398 BOLT HEX	William Adam:
Credit	24/06/2020	CR140012676	215-8029 *HOSE AS.	William Adam:
Credit	24/06/2020	CR140012676	7X-0320 BOLT	William Adam:
Credit	24/06/2020	CR140012676	431-2155 YOKE-YM	William Adam:
Credit	24/06/2020	CR140012676	7S-2945 *GASKET	William Adam:
Bill	25/06/2020	SR140010344	REMOVE & INSTALL ENGI	William Adam:
Bill	25/06/2020	SR140010344	0L-1558 BOLT	William Adam:
Bill	25/06/2020	SR140010344	2S-4071 SEAL-O-RING	William Adam:
Bill	25/06/2020	SR140010344	4D-0306 GASKET	William Adam:
Bill	25/06/2020	SR140010344	4D-0307 CAP	William Adam:
Bill	25/06/2020	SR140010344	4D-1577 SEAL O RING	William Adam:
Bill	25/06/2020	SR140010344	4P-7581 CLIP	William Adam:
Bill	25/06/2020	SR140010344	4P-8134 CLIP	William Adam:
Bill	25/06/2020	SR140010344	4W-1203 CUP	William Adam:
Bill	25/06/2020	SR140010344	4W-1204 CONE	William Adam:
Bill	25/06/2020	SR140010344	4W-8118 CLAMP	William Adam:
Bill	25/06/2020	SR140010344	5H-7844 GASKET	William Adam:
Bill	25/06/2020	SR140010344	5M-7329 SEAL O RING	William Adam:
Bill	25/06/2020	SR140010344	5P-2817 CM-HOSE STK	William Adam:

Bill	25/06/2020	SR140010344	5S-9062 SPACER	William Adam:
Bill	25/06/2020	SR140010344	5T-9093 GAGE-OIL	William Adam:
Bill	25/06/2020	SR140010344	6V-1820 BOLT	William Adam:
Bill	25/06/2020	SR140010344	6V-3822 BOLT	William Adam:
Bill	25/06/2020	SR140010344	6V-8849 BOLT	William Adam:
Bill	25/06/2020	SR140010344	6V-9748 SEAL	William Adam:
Bill	25/06/2020	SR140010344	7C-8370 CAP	William Adam:
Bill	25/06/2020	SR140010344	7D-7111 SEAL-O-RING	William Adam:
Bill	25/06/2020	SR140010344	7X-0320 BOLT	William Adam:
Bill	25/06/2020	SR140010344	7X-0346 BOLT	William Adam:
Bill	25/06/2020	SR140010344	8M-4987 SEAL O RING	William Adam:
Bill	25/06/2020	SR140010344	8M-5010 SEAL O RIN	William Adam:
Bill	25/06/2020	SR140010344	8M-8281 SEAL O RING	William Adam:
Bill	25/06/2020	SR140010344	8S-9379 HOSE	William Adam:
Bill	25/06/2020	SR140010344	8T-4136 BOLT	William Adam:
Bill	25/06/2020	SR140010344	8T-4195 BOLT	William Adam:
Bill	25/06/2020	SR140010344	8T-4994 WASHER	William Adam:
Bill	25/06/2020	SR140010344	8T-5092 BOLT	William Adam:
Bill	25/06/2020	SR140010344	8T-8925 BOLT	William Adam:
Bill	25/06/2020	SR140010344	9M-7539 SEAL O RING	William Adam:
Bill	25/06/2020	SR140010344	106-9858 HOSE	William Adam:
Bill	25/06/2020	SR140010344	111-7092 HOSE	William Adam:
Bill	25/06/2020	SR140010344	134-4040 SPIDER A-FAN	William Adam:
Bill	25/06/2020	SR140010344	148-6870 HOSE AS	William Adam:
Bill	25/06/2020	SR140010344	159-0225 HOSE AS	William Adam:
Bill	25/06/2020	SR140010344	160-8742 BOLT-HEX HEA	William Adam:
Bill	25/06/2020	SR140010344	183-7121 BOLT	William Adam:
Bill	25/06/2020	SR140010344	200-2258 GASKET	William Adam:
Bill	25/06/2020	SR140010344	209-4573 CLAMP-T'BOLT	William Adam:
Bill	25/06/2020	SR140010344	209-4578 CLAMP-T'BOLT	William Adam:
Bill	25/06/2020	SR140010344	212-6933 CLAMP-T'BOLT	William Adam:
Bill	25/06/2020	SR140010344	215-8029 HOSE AS.	William Adam:
Bill	25/06/2020	SR140010344	216-0273 SEAL-LIP TYP	William Adam:
Bill	25/06/2020	SR140010344	228-6892 HARNESS AS	William Adam:
Bill	25/06/2020	SR140010344	228-6973 HARNESS AS	William Adam:
Bill	25/06/2020	SR140010344	279-2589 PULLEY AS.	William Adam:
Bill	25/06/2020	SR140010344	299-3398 BOLT HEX	William Adam:
Bill	25/06/2020	SR140010344	309-4069 HOSE-HUMP	William Adam:
Bill	25/06/2020	SR140010344	321-7076 HOSE AS.r	William Adam:
Bill	25/06/2020	SR140010344	330-0662 BELT	William Adam:
Bill	25/06/2020	SR140010344	330-0663 BELT	William Adam:
Bill	25/06/2020	SR140010344	361-1713 TRUNNION-YM	William Adam:
Bill	25/06/2020	SR140010344	371-8094 CM HOSE BULK	William Adam:
Bill	25/06/2020	SR140010344	371-8946 CM HOSE BULK	William Adam:
Bill	25/06/2020	SR140010344	375-8345 TENSIONER AS	William Adam:
Bill	25/06/2020	SR140010344	381-2509 TENSIONER	William Adam:
Bill	25/06/2020	SR140010344	381-2512 PULLEY	William Adam:
Bill	25/06/2020	SR140010344	388-7016 CLAMP-BENT B	William Adam:
Bill	25/06/2020	SR140010344	396-0664 CAP-BRG-YM	William Adam:
Bill	25/06/2020	SR140010344	421-3152 NUT-HEX	William Adam:
Bill	25/06/2020	SR140010344	421-3183 BOLT-HEX HEA	William Adam:
Bill	25/06/2020	SR140010344	423-1980 IN HOSE-BULK	William Adam:
Bill	25/06/2020	SR140010344	431-2155 YOKE-YM	William Adam:
Bill	25/06/2020	SR140010344	F/R LBR	William Adam:
Bill	25/06/2020	SR140010344	F/R MSC	William Adam:
Bill	25/06/2020	SR140010344	20R-1785 ENG AR COMP	William Adam:

Bill	25/06/2020	SR140010344	CORE DEPOSIT	William Adam:
Bill	25/06/2020	SR140010344	CORE RETURN	William Adam:
Bill	25/06/2020	SR140010344	TRAVEL TO/FROM CUSTO	William Adam:
Bill	25/06/2020	SR140010344	ENVIR/CONSUM CHG	William Adam:
Bill	06/07/2020	INV-0467	STEM FITT MALE 1/4 NPTF	N.E Mechanic:
Bill	06/07/2020	INV-0467	FERRULE SUIT G1 & G2 N	N.E Mechanic:
Bill	06/07/2020	INV-0467	FERRULE SUIT G1 & G2 N	N.E Mechanic:
Bill	06/07/2020	INV-0467	FERRULE BODY C1T/2AT/	N.E Mechanic:
Bill	06/07/2020	INV-0467	SWIVEL STR FEM F/F O-RIN	N.E Mechanic:
Bill	06/07/2020	INV-0467	SWIVEL 45' FEM F/F O-RIN	N.E Mechanic:
Bill	06/07/2020	INV-0467	HOSE 3/4ID 2W R2	N.E Mechanic:
Bill	06/07/2020	INV-0467	FERRULE BODY C1T/2AT/	N.E Mechanic:
Bill	06/07/2020	INV-0467	SWIVEL STR FEM F/F O-RIN	N.E Mechanic:
Bill	06/07/2020	INV-0467	SWIVEL 90' FEM F/F O-RIN	N.E Mechanic:
Bill	06/07/2020	INV-0467	HOSE 1/2ID 2W R2 EXT-TEN	N.E Mechanic:
Bill	11/08/2020	1170	CAT C9 engine second hanc	GT Diesel Rep
Bill	13/08/2020	INV-0492	PLUG FF O-RING	N.E Mechanic:
Bill	13/08/2020	INV-0492	CAP FF O-RING	N.E Mechanic:
Bill	13/08/2020	INV-0492	CAP FF O-RING	N.E Mechanic:
Bill	13/08/2020	INV-0492	CAP FF O-RING	N.E Mechanic:
Bill	24/09/2020	PR140112479	243-1159 FASTENER	William Adam:
Bill	28/09/2020	PR140112527	433-3493 *HARNES AS	William Adam:
Bill	29/09/2020	PR140112551	230-6368 *BATTERY	William Adam:
Bill	29/09/2020	PR140112552	230-6368 *BATTERY	William Adam:
Bill	30/09/2020	PR140112570	239-6895 *CABLE AS.	William Adam:
Bill	08/12/2020	PR140113881	330-0662 *BELT	William Adam:
Bill	08/12/2020	PR140113881	330-0663 *BELT	William Adam:
Bill	10/12/2020	PR140113942	330-0662 *BELT	William Adam:
Bill	11/12/2020	PR140113988	8X-8073 BUSHING	William Adam:
Bill	11/12/2020	PR140113988	8T-6871 BOLT	William Adam:
Bill	12/12/2020	10140690	THREAD REPAIR KIT UNC	Mallee Bearing
Bill	14/12/2020	PR140114019	8X-8074 BUSHING	William Adam:
Bill	14/12/2020	PR140114019	8X-8073 BUSHING	William Adam:
Bill	15/12/2020	PR140114043	4C-8423 INSERT	William Adam:
Bill	15/12/2020	PR140114043	8X-8074 BUSHING	William Adam:
Bill	17/01/2021	INV-0579	NIPPLE 9/16 X 9/16 JIC	N.E Mechanic:
Bill	17/01/2021	INV-0579	STEM 9/16"JIC-F*-04 HOSE	N.E Mechanic:
Bill	17/01/2021	INV-0579	FERRULE SUIT G1 & G2 N	N.E Mechanic:
Bill	17/01/2021	INV-0579	Spiral Guard 40mm	N.E Mechanic:
Bill	17/01/2021	INV-0579	HOSE 1/4 N/SKIVE SAE100	N.E Mechanic:
Bill	17/01/2021	INV-0573	FERRULE BODY C1T/2AT/	N.E Mechanic:
Bill	17/01/2021	INV-0573	STEM 90' FLGE CODE 61	N.E Mechanic:
Bill	17/01/2021	INV-0573	STEM 45' FLGE CODE 61	N.E Mechanic:
Bill	17/01/2021	INV-0573	HOSE 1 " ID 4000 PSI	N.E Mechanic:
Bill	17/01/2021	INV-0573	PLUG FF O-RING	N.E Mechanic:
Bill	17/01/2021	INV-0573	PLUG FF O-RING	N.E Mechanic:
Bill	17/01/2021	INV-0573	SWIVEL 90' FEM F/F O-RIN	N.E Mechanic:
Bill	17/01/2021	INV-0573	SWIVEL STR FEM F/F O-RIN	N.E Mechanic:
Bill	17/01/2021	INV-0573	SWIVEL 90LONG FEM F/F	N.E Mechanic:
Bill	17/01/2021	INV-0573	FERRULE BODY C1T/2AT/	N.E Mechanic:
Bill	17/01/2021	INV-0573	HOSE 3/8 XH HI-TEMP	N.E Mechanic:
Bill	19/01/2021	1483772	KIT-TWIN RESERVOIR	Mildura Truck
Bill	29/01/2021	PR140114784	384-3460 CAP-BRG-GD	William Adam:
Bill	29/01/2021	PR140114784	7X-0388 BOLT	William Adam:
Bill	01/02/2021	PR140114812	394-0210 TRUNNION-GD	William Adam:
Bill	09/02/2021	10143953	KIT UNC 5/8 - 11 (33100)	Mallee Bearing

Bill	17/02/2021	PR140115243	4D-1577 *SEAL O RING	William Adam:
Bill	17/02/2021	PR140115243	6G-8370 *SHIM PACK	William Adam:
Bill	17/02/2021	PR140115243	9G-5319 *SEAL G	William Adam:
Bill	17/02/2021	PR140115243	1A-8537 CAPSCREW	William Adam:
Bill	17/02/2021	PR140115243	6V-8179 *RING	William Adam:
Bill	17/02/2021	PR140115243	365-1382 *KIT-SEAL-H.C	William Adam:
Bill	17/02/2021	PR140115244	399-4397 BRG-ALIGN-GD	William Adam:
Bill	26/02/2021	PR140115500	4H-6112 BREATHER (SWIN	William Adam:
Bill	01/03/2021	PR140115548	188-2461 VALVE GP-SOLEI	William Adam:
Bill	03/03/2021	309645	WHEEL AS 621/3/7 29" REC	RDW Parts
Bill	03/03/2021	309645	Core Deposit	RDW Parts
Bill	10/03/2021	PR140115787	1P-9593 CONE	William Adam:
Bill	10/03/2021	PR140115787	1P-9594 CUP	William Adam:
Bill	10/03/2021	PR140115787	2P-1823 CUP	William Adam:
Bill	10/03/2021	PR140115787	2P-1824 CONE	William Adam:
Bill	11/03/2021	PR140115814	1B-5174 PLUG	William Adam:
Bill	11/03/2021	PR140115814	7M-7410 PLUG-PIP	William Adam:
Bill	11/03/2021	PR140115814	5P-5855 BOLT	William Adam:
Bill	11/03/2021	PR140115814	5P-6628 WIRE-LOC	William Adam:
Bill	11/03/2021	PR140115814	7F-7781 WASHER	William Adam:
Bill	11/03/2021	PR140115814	7F-7782 RETAINER	William Adam:
Bill	11/03/2021	PR140115814	7F-7783 SPRING	William Adam:
Bill	11/03/2021	PR140115815	10R-3399 SHOE AS	William Adam:
Bill	11/03/2021	PR140115815	10R-3399 CORE DEPOSIT	William Adam:
Bill	11/03/2021	PR140115815	5P-5855 BOLT	William Adam:
Bill	11/03/2021	PR140115815	380-7396 PIN-GD	William Adam:
Bill	11/03/2021	PR140115815	7F-7782 RETAINER	William Adam:
Bill	11/03/2021	PR140115816	5P-6628 WIRE-LOCK	William Adam:
Credit	07/04/2021	CR140013132	10R-3399 CORE RETURN	William Adam:
Bill	08/04/2021	PR140116369	8W-9266 *SHIM	William Adam:
Bill	09/04/2021	PR140116397	8W-9267 *SHIM	William Adam:
Credit	14/04/2021	309645	CORE CREDIT 8W9986 O/	RDW Parts
Bill	26/04/2021	PR140116726	10R-3399 SHOE AS	William Adam:
Bill	26/04/2021	PR140116726	10R-3399 CORE DEPOSIT	William Adam:
Bill	04/05/2021	INV-0627	STEM FLGE CODE 61	N.E Mechanic:
Bill	04/05/2021	INV-0627	STEM 45' FLGE CODE 61	N.E Mechanic:
Bill	04/05/2021	INV-0627	FERRULE NON-SKIVE C12	N.E Mechanic:
Bill	04/05/2021	INV-0627	HOSE 1-1/4" 4000 PSI	N.E Mechanic:
Bill	12/05/2021	PR140117138	279-2589 PULLEY AS.	William Adam:
Bill	12/05/2021	PR140117138	330-0663 *BELT	William Adam:
Bill	12/05/2021	PR140117138	330-0662 *BELT	William Adam:
Bill	13/05/2021	PR140117168	279-2589 PULLEY AS.	William Adam:
Bill	14/05/2021	366602	29" NDT Rim Inspection	Tyre Doctor
Bill	14/05/2021	PR140117215	9X-4494 *LAMP 24-VOLT M	William Adam:
Bill	17/05/2021	PR140117244	271-9369 *HOSE AS.	William Adam:
Bill	17/05/2021	PR140117244	272-0009 *HOSE AS.	William Adam:
Bill	17/05/2021	PR140117245	242-2545 *KIT-SEAL-H.C	William Adam:
Bill	20/05/2021	438135	BEARING SPHERICAL 16G	ITR Victoria
Bill	20/05/2021	438135	BEARING SPHERICAL	ITR Victoria
Bill	20/05/2021	438135	BEARING SLEEVE	ITR Victoria
Credit Card Charge	25/05/2021	IC99262	Drum 623G	Don Clark Tra
Bill	10/06/2021	PR140117751	6V-3965 NIPPLE A	William Adam:
Bill	10/06/2021	PR140117751	8C-3447 CAP	William Adam:
Bill	10/06/2021	PR140117751	8C-3445 CAP DUST	William Adam:
Bill	10/06/2021	PR140117751	8C-3451 CAP	William Adam:
Bill	10/06/2021	PR140117751	6V-0852 CAP	William Adam:

Bill	10/06/2021	PR140117751	204-8976 PAN AS-FLAT	William Adam:
Bill	18/06/2021	P2PR0002120	1V-9725 HINGE	William Adam:
Bill	18/06/2021	P2PR0002120	5D-6149 SCREEN A	William Adam:
Bill	22/06/2021	P2PR0003304	322-8568 BUTTON AS-HO	William Adam:
Bill	07/07/2021	449144	ROUTER BIT STD SCRAPE ITR	Victoria
Bill	07/07/2021	449144	CUTTING EDGE 18H 22MM ITR	Victoria
Bill	29/07/2021	P2PR0019256	242-2542 *KIT-SEAL HYDR	William Adam:
Bill	29/07/2021	P2PR0019256	380-7378 BRG-SLV-GD	William Adam:
Bill	29/07/2021	P2PR0019257	242-2545 *KIT-SEAL-H.C	William Adam:
Bill	30/07/2021	P2PR0019857	385-3805 PIN-GD	William Adam:
Bill	03/09/2021	461594	ROUTER BIT STD SCRAPE ITR	Victoria
Bill	09/09/2021	6381	FMS 50x10mm 6M/LENGTH RTG	Welding
Bill	12/09/2021	P2PR0038728	330-0662 *BELT	William Adam:
Bill	12/09/2021	P2PR0038728	330-0663 *BELT	William Adam:
Bill	12/09/2021	P2PR0038728	381-2509 TENSIONER	William Adam:
Bill	13/09/2021	P2PR0039290	375-8345 TENSIONER AS	William Adam:
Bill	15/09/2021	P2PR0040496	386-4920 BRG-SLV-GD	William Adam:
Bill	15/09/2021	P2PR0040496	5J-2445 BEARING	William Adam:
Bill	16/09/2021	P2PR0041133	244-0954 *KIT-SEAL-H.C	William Adam:
Bill	16/09/2021	P2PR0041133	5J-2445 BEARING	William Adam:
Bill	16/09/2021	P2PR0041133	8W-8585 PIN A	William Adam:
Bill	16/09/2021	P2PR0041141	4T-5434 PIN A	William Adam:
Bill	16/09/2021	P2PR0041141	8J-7921 PIN A	William Adam:
Bill	16/09/2021	P2PR0041141	581-6994 BRG-ALIGN-GD	William Adam:
Bill	17/09/2021	INV-0700	1/2"CODE 61 O-RING FLG I	N.E Mechanic:
Bill	17/09/2021	INV-0700	3/4' CD61 BLANKING PLUG	N.E Mechanic:
Bill	17/09/2021	INV-0700	FERRULE BODY C1T/2AT/	N.E Mechanic:
Bill	17/09/2021	INV-0700	STEM 1.1/16"JIC-F*-12 HO	N.E Mechanic:
Bill	17/09/2021	INV-0700	NIPPLE 1" NPT X 1-1/16 JIC	N.E Mechanic:
Bill	17/09/2021	INV-0700	HOSE STRAP 800MM FRA	N.E Mechanic:
Bill	17/09/2021	INV-0700	1"CODE 62 O RING FLANG	N.E Mechanic:
Bill	17/09/2021	INV-0700	FERRULE BODY C1T/2AT/	N.E Mechanic:
Bill	17/09/2021	INV-0700	STEM FITT MALE 3/4 NPTF	N.E Mechanic:
Bill	17/09/2021	INV-0700	SOCKET 3/8 NPT	N.E Mechanic:
Bill	17/09/2021	INV-0700	PLUG 3/8 NPTF	N.E Mechanic:
Bill	17/09/2021	INV-0700	BALL VALVE 3/8"BSPP 2 W	N.E Mechanic:
Bill	17/09/2021	INV-0700	NIPPLE 3/8 X 3/8 NPT	N.E Mechanic:
Bill	17/09/2021	P2PR0041710	380-7563 BRG-SLV-GD	William Adam:
Bill	17/09/2021	P2PR0041710	5J-1980 PIN	William Adam:
Bill	17/09/2021	P2PR0041711	8J-7921 PIN A	William Adam:
Bill	20/09/2021	P2PR0042373	325-6018 BRG-GD	William Adam:
Bill	20/09/2021	P2PR0042373	439-4544 RING-GD	William Adam:
Bill	22/09/2021	INV-39546	Build up and machine ram	at TBAS Precisi
Bill	23/09/2021	P2PR0044245	7F-7781 WASHER	William Adam:
Bill	23/09/2021	P2PR0044245	7F-7782 RETAINER	William Adam:
Bill	23/09/2021	P2PR0044245	7F-7783 SPRING	William Adam:
Bill	23/09/2021	P2PR0044245	5B-3265 *GASKET	William Adam:
Bill	23/09/2021	P2PR0044245	6F-4855 *SEAL	William Adam:
Bill	23/09/2021	P2PR0044245	1A-8537 CAPSCREW	William Adam:
Bill	23/09/2021	P2PR0044246	8D-4004 SPRING	William Adam:
Bill	23/09/2021	P2PR0044246	5B-3265 *GASKET	William Adam:
Bill	23/09/2021	P2PR0044246	9G-5319 *SEAL G	William Adam:
Bill	27/09/2021	P2PR0044988	7F-7780 PIN	William Adam:
Bill	27/09/2021	P2PR0044988	6G-8370 *SHIM PACK	William Adam:
Bill	27/09/2021	P2PR0044988	380-7396 PIN-GD	William Adam:
Bill	27/09/2021	P2PR0044988	3J-9173 BOLT	William Adam:

Bill	30/09/2021	P2PR0046857	8J-7921 PIN A	William Adam:
Bill	30/09/2021	P2PR0046858	3Y-2768 *RING	William Adam:
Bill	01/10/2021	INV-39593	Repair Tow Hitch.	TBAS Precisc
Bill	12/10/2021	INV-39646	Build UP And Machine Ram	TBAS Precisc
Bill	14/10/2021	P2PR0052728	1P-9593 CONE	William Adam:
Bill	14/10/2021	P2PR0052728	1P-9594 CUP	William Adam:
Bill	14/10/2021	P2PR0052728	2P-1823 CUP	William Adam:
Bill	14/10/2021	P2PR0052728	2P-1824 CONE	William Adam:
Bill	14/10/2021	P2PR0052728	5P-5855 BOLT	William Adam:
Bill	14/10/2021	P2PR0052729	1A-8537 CAPSCREW	William Adam:
Credit	27/10/2021	P3PR0003992	10R-3399 CORE RETURN	William Adam:
Bill	29/10/2021	6518	Aluminium Welding Services	RTG Welding
Bill	29/10/2021	6518	Welding Consumables Char	RTG Welding
Bill	10/11/2021	6542	Aluminium Welding Services	RTG Welding
Bill	10/11/2021	6542	Welding Consumables Char	RTG Welding
Bill	16/11/2021	P2PR0065838	7S-2944 HOUSING	William Adam:
Bill	16/11/2021	P2PR0065838	5M-7937 DOWEL	William Adam:
Bill	16/11/2021	P2PR0065838	8S-9094 PLUG	William Adam:
Bill	16/11/2021	P2PR0065838	1T-1993 WHEEL-TL	William Adam:
Bill	16/11/2021	P2PR0065838	4H-1440 PIN	William Adam:
Bill	16/11/2021	P2PR0065838	1T-2069 CARRIER-I	William Adam:
Bill	16/11/2021	P2PR0065838	1T-0387 WHEEL	William Adam:
Bill	16/11/2021	P2PR0065838	2H-9192 BEARING	William Adam:
Bill	16/11/2021	P2PR0065838	1T-0839 GEAR	William Adam:
Bill	16/11/2021	P2PR0065838	1T-0844 CARRIER J	William Adam:
Bill	16/11/2021	P2PR0065838	1T-0063 SLEEVE	William Adam:
Bill	16/11/2021	P2PR0065838	1T-0968 RACE	William Adam:
Bill	16/11/2021	P2PR0065838	5H-5312 ROLLER A	William Adam:
Bill	16/11/2021	P2PR0065838	1T-1341 *RING-SEA	William Adam:
Bill	16/11/2021	P2PR0065838	1T-0417 BOLT	William Adam:
Bill	16/11/2021	P2PR0065838	1T-0069 *RING	William Adam:
Bill	16/11/2021	P2PR0065838	1T-0414 BOLT	William Adam:
Bill	16/11/2021	P2PR0065838	3F-3727 *RING	William Adam:
Bill	16/11/2021	P2PR0065838	481-2061 STATOR A	William Adam:
Bill	16/11/2021	P2PR0065838	1T-0076 SPACER	William Adam:
Bill	16/11/2021	P2PR0065838	9P-4253 DISC A	William Adam:
Bill	16/11/2021	P2PR0065838	3S-1281 *RING	William Adam:
Bill	16/11/2021	P2PR0065838	5S-3586 PISTON	William Adam:
Bill	16/11/2021	P2PR0065838	8S-3370 *RING	William Adam:
Bill	16/11/2021	P2PR0065838	5S-3579 GEAR	William Adam:
Bill	16/11/2021	P2PR0065838	1T-0822 BOLT	William Adam:
Bill	16/11/2021	P2PR0065838	1T-0846 RETAINER	William Adam:
Bill	16/11/2021	P2PR0065838	1T-0532 BEARING	William Adam:
Bill	16/11/2021	P2PR0065838	2K-0723 *RING	William Adam:
Bill	16/11/2021	P2PR0065838	8S-6247 RETAINER	William Adam:
Bill	16/11/2021	P2PR0065838	1M-3937 *RING	William Adam:
Bill	18/11/2021	P2PR0066912	276-7018 *KIT CAP PLUG	William Adam:
Bill	22/11/2021	P2PR0068258	9X-3271 ADAPTER	William Adam:
Bill	07/12/2021	P2PR0075355	5M-6126 BEARING A	William Adam:
Bill	07/12/2021	P2PR0075353	4B-9782 BALL	William Adam:
Bill	07/12/2021	P2PR0075353	5M-5018 BEARING-	William Adam:
Bill	07/12/2021	P2PR0075353	2D-6642 BALL	William Adam:
Bill	07/12/2021	P2PR0075353	8E-8307 DISC	William Adam:
Bill	07/12/2021	P2PR0075353	3S-2708 PIN	William Adam:
Bill	07/12/2021	P2PR0075353	5F-1678 *SEAL	William Adam:
Bill	07/12/2021	P2PR0075353	1T-0416 BOLT	William Adam:

Bill	07/12/2021	P2PR0075353	9M-2095	*RING-RET William Adam:
Bill	07/12/2021	P2PR0075353	6K-4936	BOLT William Adam:
Bill	07/12/2021	P2PR0075353	6Y-5793	*RING SEA William Adam:
Bill	07/12/2021	P2PR0075353	9M-1503	*RING William Adam:
Bill	07/12/2021	P2PR0075353	5K-9107	BOLT William Adam:
Bill	07/12/2021	P2PR0075353	8E-8304	DISC William Adam:
Bill	07/12/2021	P2PR0075353	5M-6126	BEARING William Adam:
Bill	07/12/2021	P2PR0075353	4M-9592	SPRING William Adam:
Bill	07/12/2021	P2PR0075353	9M-4335	DOWEL-R William Adam:
Bill	07/12/2021	P2PR0075353	1M-4169	*RING William Adam:
Bill	07/12/2021	P2PR0075353	6F-0155	*RING William Adam:
Bill	07/12/2021	P2PR0075353	6B-6863	DOWEL William Adam:
Bill	07/12/2021	P2PR0075353	9M-1974	WASHER William Adam:
Bill	07/12/2021	P2PR0075353	2K-8257	*SEAL William Adam:
Bill	07/12/2021	P2PR0075353	2H-2665	*SEAL William Adam:
Bill	07/12/2021	P2PR0075353	216-0273	*SEAL-LIP William Adam:
Bill	07/12/2021	P2PR0075353	0L-1026	PLUG William Adam:
Bill	07/12/2021	P2PR0075353	130-5300	CLIP William Adam:
Bill	07/12/2021	P2PR0075353	8M-5010	*SEAL O R William Adam:
Bill	07/12/2021	P2PR0075353	8M-8157	*SEAL O R William Adam:
Bill	07/12/2021	P2PR0075353	2J-6356	*RING-LOC William Adam:
Bill	07/12/2021	P2PR0075353	9H-0223	*SEAL William Adam:
Bill	07/12/2021	P2PR0075353	5B-3718	*SEAL William Adam:
Bill	07/12/2021	P2PR0075353	8S-5575	*SEAL William Adam:
Bill	07/12/2021	P2PR0075353	114-6658	WASHER William Adam:
Bill	07/12/2021	P2PR0075353	8M-8544	*SEAL O R William Adam:
Bill	07/12/2021	P2PR0075353	214-7568	*SEAL-O F William Adam:
Bill	07/12/2021	P2PR0075353	0S-1617	BOLT William Adam:
Bill	07/12/2021	P2PR0075353	3B-4505	LOCKWAS William Adam:
Bill	07/12/2021	P2PR0075353	3B-4506	LOCKWAS William Adam:
Bill	07/12/2021	P2PR0075353	5M-7914	SPACER £ William Adam:
Bill	07/12/2021	P2PR0075353	5M-7915	SPACER £ William Adam:
Bill	08/12/2021	P2PR0075950	0L-1026 PLUG	William Adam:
Bill	08/12/2021	P2PR0075949	102-8671	DISC William Adam:
Bill	08/12/2021	P2PR0075949	5M-2051	BEARING William Adam:
Bill	08/12/2021	P2PR0075949	8E-8307	DISC William Adam:
Bill	08/12/2021	P2PR0075949	9G-0335	*RING William Adam:
Bill	08/12/2021	P2PR0075949	8E-2477	DISC-FRIC William Adam:
Bill	08/12/2021	P2PR0075949	3P-2792	*SEAL RIN(William Adam:
Bill	08/12/2021	P2PR0075949	370-8592	PLATE-CL William Adam:
Bill	08/12/2021	P2PR0075949	1P-9261	*RING William Adam:
Bill	08/12/2021	P2PR0075949	3K-2518	BEARING William Adam:
Bill	08/12/2021	P2PR0075949	1T-0479	*RING William Adam:
Bill	08/12/2021	P2PR0075949	8S-3517	BEARING William Adam:
Bill	08/12/2021	P2PR0075949	6P-6739	SHAFT-PL William Adam:
Bill	08/12/2021	P2PR0075949	4M-5016	SPRING William Adam:
Bill	08/12/2021	P2PR0075949	4M-7092	*RING William Adam:
Bill	08/12/2021	P2PR0075949	3K2510	PIN William Adam:
Bill	08/12/2021	P2PR0075949	8P-8744	*RING-SEA William Adam:
Bill	08/12/2021	P2PR0075949	8P-9569	*RING-SEA William Adam:
Bill	08/12/2021	P2PR0075949	3K-2556	*RING William Adam:
Bill	08/12/2021	P2PR0075949	1M-4093	*RING-RET William Adam:
Bill	08/12/2021	P2PR0075949	9G-0334	*RING William Adam:
Bill	08/12/2021	P2PR0075949	1P-8199	*GASKET William Adam:
Bill	08/12/2021	P2PR0075949	8B-9777	*GASKET William Adam:
Bill	08/12/2021	P2PR0075949	8M-8621	*GASKET William Adam:

Bill	08/12/2021	P2PR0075949	136-7813	BEARING- William Adam:
Bill	08/12/2021	P2PR0075949	7G-7178	*SHIM PAC William Adam:
Bill	08/12/2021	P2PR0075949	3P-8218	*RING-LOC William Adam:
Bill	08/12/2021	P2PR0075949	030-8535	BOLT William Adam:
Bill	08/12/2021	P2PR0075949	141-8891	CONE William Adam:
Bill	08/12/2021	P2PR0075949	7G-7145	*SHIM PAC William Adam:
Bill	08/12/2021	P2PR0075949	8M-4437	*SEAL O F William Adam:
Bill	08/12/2021	P2PR0075949	1T-0738	WASHER William Adam:
Bill	08/12/2021	P2PR0075949	7M-2082	*GASKET William Adam:
Bill	08/12/2021	P2PR0075949	6V-0405	*SEAL-BOI William Adam:
Bill	08/12/2021	P2PR0075949	2S-1381	SPRING William Adam:
Bill	08/12/2021	P2PR0075949	8M-8514	*SEAL O I William Adam:
Bill	08/12/2021	P2PR0075949	131-8194	*HARNES William Adam:
Bill	08/12/2021	P2PR0075949	296-3423	*SENSOR I William Adam:
Bill	08/12/2021	P2PR0075949	8C-9648	MOUNT William Adam:
Bill	08/12/2021	P2PR0075949	0R-8040	PUMP GP William Adam:
Bill	08/12/2021	P2PR0075949	0R-8040	CORE DE William Adam:
Bill	08/12/2021	P2PR0075949	4D-2813	SPRING William Adam:
Bill	08/12/2021	P2PR0075949	330-3517	*SEAL-O-F William Adam:
Bill	08/12/2021	P2PR0075949	214-4040	VALVE GF William Adam:
Bill	08/12/2021	P2PR0075949	9G-0333	*SEAL-RIN William Adam:
Bill	08/12/2021	P2PR0075949	6I-9255	DISC-FRIC William Adam:
Bill	09/12/2021	P2PR0076556	4S-6712	*RING William Adam:
Bill	09/12/2021	P2PR0076556	5M-3406	*RING William Adam:
Bill	09/12/2021	P2PR0076556	2P-2913	*RING William Adam:
Bill	09/12/2021	P2PR0076556	9G-0954	GEAR A William Adam:
Bill	09/12/2021	P2PR0076556	7S-3002	BEARING William Adam:
Bill	09/12/2021	P2PR0076556	7G-2501	GEAR PL William Adam:
Bill	09/12/2021	P2PR0076556	9W-5353	RACE RLI William Adam:
Bill	09/12/2021	P2PR0076556	6V-2304	BEARING . William Adam:
Bill	09/12/2021	P2PR0076556	0L-2072	CLIP William Adam:
Bill	09/12/2021	P2PR0076556	5P-1777	RACE William Adam:
Bill	09/12/2021	P2PR0076556	5P-1776	RACE&RO William Adam:
Bill	09/12/2021	P2PR0076556	1P-2566	CUP William Adam:
Bill	09/12/2021	P2PR0076556	141-8891	CONE William Adam:
Bill	09/12/2021	P2PR0076556	9W-1398	BOLT-SPE William Adam:
Bill	09/12/2021	P2PR0076556	1S-3206	BEARING William Adam:
Bill	09/12/2021	P2PR0076556	8P-4764	PIN William Adam:
Bill	09/12/2021	P2PR0076556	8S-6377	PIN-LOCK William Adam:
Bill	09/12/2021	P2PR0076556	3S-6925	SPRING William Adam:
Bill	09/12/2021	P2PR0076556	214-4040	VALVE GF William Adam:
Bill	09/12/2021	P2PR0076556	7G-0825	PLATE William Adam:
Bill	10/12/2021	P2PR0077183	1F-5546 DOWEL	William Adam:
Bill	14/12/2021	P2PR0078382	7G-3465 GEAR PLANET	William Adam:
Bill	14/12/2021	P2PR0078382	9G-0328 GEAR	William Adam:
Bill	21/12/2021	P2PR0081669	3T-9165 SPRING	William Adam:
Bill	21/12/2021	P2PR0081668	3T-9165 SPRING	William Adam:
Bill	25/01/2022	P2PR0092419	5M-7329 *SEAL O RING	William Adam:
Bill	27/01/2022	P2PR0093196	9W-2021 BEARING	William Adam:
Bill	21/02/2022	P2PR0104006	2H-3928 *SEAL	William Adam:
Bill	21/02/2022	P2PR0104006	5K-1770 *SEAL O RING	William Adam:
Bill	21/02/2022	P2PR0104006	343-4464 ELEMENT-XMSN	William Adam:
Bill	21/02/2022	P2PR0104005	5M-2894	WASHER- William Adam:
Bill	21/02/2022	P2PR0104005	0L-2070	CAP SCRE William Adam:
Bill	21/02/2022	P2PR0104005	5M-7329	*SEAL O R William Adam:
Bill	21/02/2022	P2PR0104005	3D-2824	*SEAL O R William Adam:

Bill	21/02/2022	P2PR0104005	8S-6251	*SEAL	William Adam:
Bill	21/02/2022	P2PR0104005	8M-4443	*SEAL O R	William Adam:
Bill	21/02/2022	P2PR0104005	8M-4432	*SEAL O R	William Adam:
Bill	21/02/2022	P2PR0104005	7F-8268	*SEAL O RI	William Adam:
Bill	21/02/2022	P2PR0104005	175-7895	*SEAL-O-R	William Adam:
Bill	21/02/2022	P2PR0104005	2M-4453	*SEAL O-F	William Adam:
Bill	21/02/2022	P2PR0104005	3J-1907	*SEAL	William Adam:
Bill	22/02/2022	P2PR0104686	3S-6924	*RING	William Adam:
Bill	22/02/2022	P2PR0104686	330-3517	*SEAL-O-RING	William Adam:
Bill	22/02/2022	P2PR0104686	8M-4431	*SEAL-O-RING	William Adam:
Bill	22/02/2022	P2PR0104686	7S-2945	*GASKET	William Adam:
Bill	23/02/2022	P2PR0105294	2S-0795	*GASKET	William Adam:
Bill	23/02/2022	P2PR0105294	8M-5661	*SEAL O RING	William Adam:
Bill	23/02/2022	P2PR0105294	8M-5010	*SEAL O RIN	William Adam:
Bill	23/02/2022	P2PR0105292	107-3116	*SEAL O RING	William Adam:
Bill	23/02/2022	P2PR0105293	8M-8544	*SEAL O RING	William Adam:
Bill	23/02/2022	P2PR0105291	5B-3718	*SEAL	William Adam:
Bill	23/02/2022	P2PR0105291	7J-2036	*SEAL O RING	William Adam:
Bill	23/02/2022	P2PR0105285	8S-6249	*RING	William Adam:
Bill	24/02/2022	P2PR0105927	10R-3667	CORE AS OIL	William Adam:
Bill	24/02/2022	P2PR0105927	10R-3667	CORE DEPOSIT	William Adam:
Bill	24/02/2022	P2PR0105928	180-3907	*SEAL-INTEGRAL	William Adam:
Bill	25/02/2022	P2PR0106594	5F-8000	*RING	William Adam:
Bill	25/02/2022	P2PR0106594	3D-2824	*SEAL O RI	William Adam:
Bill	25/02/2022	P2PR0106594	6V-9746	*SEAL-O-R	William Adam:
Bill	25/02/2022	P2PR0106594	2D-5248	*GASKET	William Adam:
Bill	25/02/2022	P2PR0106594	8M-5661	*SEAL O F	William Adam:
Bill	25/02/2022	P2PR0106594	8M-5010	*SEAL O R	William Adam:
Bill	25/02/2022	P2PR0106594	8M-4987	*SEAL O R	William Adam:
Bill	25/02/2022	P2PR0106594	4J-0522	*SEAL-O-RI	William Adam:
Bill	25/02/2022	P2PR0106594	1P-3705	*SEAL	William Adam:
Bill	25/02/2022	P2PR0106594	175-7896	*SEAL-O-R	William Adam:
Bill	25/02/2022	P2PR0106594	3J-7354	*SEAL O RI	William Adam:
Bill	25/02/2022	P2PR0106594	2M-9780	*SEAL O R	William Adam:
Bill	25/02/2022	P2PR0106590	2M-3818	*SEAL O RIN	William Adam:
Bill	25/02/2022	SI92974	DISC ASSEMBLY (A/market	Smith Equipm	
Bill	28/02/2022	P2PR0106786	7X-0521	WASHER	William Adam:
Bill	28/02/2022	P2PR0106786	7X-0582	WASHER	William Adam:
Bill	28/02/2022	P2PR0106786	6V-8182	NUT	William Adam:
Bill	28/02/2022	P2PR0106786	9X-3265	*SEAL-CONNECTC	William Adam:
Bill	28/02/2022	P2PR0106786	6V-8189	NUT	William Adam:
Bill	28/02/2022	P2PR0106786	7X-0772	WASHER	William Adam:
Bill	28/02/2022	P2PR0106786	8C-9987	WASHER	William Adam:
Bill	28/02/2022	P2PR01070328	6V-8629	*ELBOW	William Adam:
Bill	28/02/2022	P2PR01070328	2M-9780	*SEAL O RING	William Adam:
Bill	28/02/2022	P2PR0107325	6D-4733	*GASKET	William Adam:
Bill	28/02/2022	P2PR0107327	5F-0149	*RING	William Adam:
Bill	28/02/2022	P2PR0107327	6G-0078	BREATHER	William Adam:
Bill	01/03/2022	P2PR0107937	6D-4733	*GASKET	William Adam:
Bill	01/03/2022	P2PR0107937	299-3399	BOLT HEX	William Adam:
Bill	01/03/2022	P2PR0107937	7X-0377	BOLT	William Adam:
Bill	01/03/2022	P2PR0107937	7X-0582	WASHER	William Adam:
Bill	01/03/2022	P2PR0107937	9X-3265	*SEAL-CO	William Adam:
Bill	01/03/2022	P2PR0107937	6G-9943	BOLT	William Adam:
Bill	01/03/2022	P2PR0107937	1P-7115	*MOUNT A'	William Adam:
Bill	01/03/2022	P2PR0107937	8C-9987	WASHER	William Adam:

Bill	03/03/2022	P2PR0108690	186-4095 *SENSOR GP-PR	William Adam:
Bill	07/03/2022	P2PR0110752	5P-7854 CLIP	William Adam:
Bill	08/03/2022	P2PR0111418	6V-3966 NIPPLE A	William Adam:
Bill	09/03/2022	P2PR0112032	3B-8485 FITTING	William Adam:
Bill	09/03/2022	P2PR0112032	351-9918 *LAMP-HALOGEN	William Adam:
Bill	09/03/2022	P2PR0112032	479-5402 *PAINT-MATTER	William Adam:
Bill	09/03/2022	P2PR0112033	5WA0001 NEWCAT YELLO	William Adam:
Bill	09/03/2022	P2PR0112036	9X-3402 SOCKET	William Adam:
Bill	10/03/2022	P2PR0112712	230-5008 PLUG AS-CONNE	William Adam:
Bill	10/03/2022	P2PR0112712	455-0706 *SEAL-CONNECT	William Adam:
Bill	10/03/2022	P2PR0112712	338-1942 TIMER AS-ON DE	William Adam:
Bill	10/03/2022	P2PR0112712	243-4507 *RECEPTACLE A	William Adam:
Bill	11/03/2022	INV-2134	CHECK AC FOUND COMPF	Wakefield Alle
Bill	22/03/2022	1803779	Leica MCC1309 GNSS Ante	C R Kennedy .
Bill	22/03/2022	1803779	Leica GAT2 Gainflex Radio	C R Kennedy .
Bill	22/03/2022	1803779	LABOUR - MACHINE CONT	C R Kennedy .
Bill	22/03/2022	1803779	Leica 1 yr. iCG80 Basic	C R Kennedy .
Bill	22/03/2022	1803779	Leica 1 yr. iCON 3D Panel	C R Kennedy .
Bill	22/03/2022	1803780	Leica CSW315 iCON Office	C R Kennedy .
Bill	23/03/2022	P2PR0117851	102-8671 DISC	William Adam:
Bill	29/03/2022	P2PR0119866	1982806 TC GP	William Adam:
Bill	01/04/2022	P2PR0122248	102-8671 DISC	William Adam:
Credit	19/04/2022	P3PR0008509	0R-8040 CORE RETURN	William Adam:
Credit	19/04/2022	P3PR0008510	10R-3667 CORE RETURN	William Adam:
Bill	19/04/2022	P2PR0128492	4D-0582 UNION	William Adam:
Bill	19/04/2022	P2PR0128492	4D-0577 UNION	William Adam:
Bill	19/04/2022	P2PR0128492	3D-7587 ADAPTER-ELBO	William Adam:
Bill	21/04/2022	P2PR0129719	3B-5301 SPLIT PIN	William Adam:
Bill	21/04/2022	P2PR0129719	2D-2444 *SEAL	William Adam:
Bill	21/04/2022	P2PR0129720	8W-8357 ACTUATOR G	William Adam:
Bill	21/04/2022	P2PR0129720	8F-9838 YOKE A	William Adam:
Bill	21/04/2022	P2PR0129720	8B-1056 PIN	William Adam:
Bill	21/04/2022	P2PR0129720	179-3149 STUD-TAPERLO	William Adam:
Bill	21/04/2022	P2PR0129721	8X-8883 *HOSE AS	William Adam:
Bill	21/04/2022	P2PR0129721	8X-8887 *HOSE AS	William Adam:
Bill	21/04/2022	P2PR0129722	7X-0449 NUT	William Adam:
Bill	21/04/2022	P2PR0129722	8C-6913 WASHER	William Adam:
Bill	21/04/2022	P2PR0129723	SOS002 OIL SMPL KIT	William Adam:
Bill	22/04/2022	P2PR0130292	347-5705 STEP A	William Adam:
Bill	29/04/2022	P2PR0133088	144-7291 *GASKET	William Adam:
Bill	29/04/2022	P2PR0133088	1B-3955 CUP	William Adam:
Bill	29/04/2022	P2PR0133088	1B-3953 BEARING-CONE	William Adam:
Bill	29/04/2022	P2PR0133087	144-7291 *GASKET	William Adam:
Bill	29/04/2022	P2PR0133087	3J-4776 *SEAL	William Adam:
Bill	02/05/2022	P2PR0133708	2J-5637 PIN	William Adam:
Bill	02/05/2022	P2PR0133708	4H-2686 *RING	William Adam:
Bill	02/05/2022	P2PR0133708	380-7378 BRG-SLV-	William Adam:
Bill	02/05/2022	P2PR0133708	102-1440 RETAINEF	William Adam:
Bill	02/05/2022	P2PR0133708	3B-4627 COTTER F	William Adam:
Bill	02/05/2022	P2PR0133708	7D-1649 WASHER	William Adam:
Bill	02/05/2022	P2PR0133708	5P-8247 WASHER	William Adam:
Bill	02/05/2022	P2PR0133708	5P-8245 WASHER-	William Adam:
Bill	02/05/2022	P2PR0133708	8W-9517 SPACER	William Adam:
Bill	02/05/2022	P2PR0133709	380-7378 BRG-SLV-GD	William Adam:
Bill	02/05/2022	P2PR0133709	8C-4436 BOLT	William Adam:
Bill	03/05/2022	P2PR0134348	3G-7853 RETAINEF	William Adam:

Bill	03/05/2022	P2PR0134348	380-7374	BRG-SLV	William Adam:
Bill	03/05/2022	P2PR0134348	380-7378	BRG-SLV-	William Adam:
Bill	03/05/2022	P2PR0134348	380-7394	PIN AS-GI	William Adam:
Bill	03/05/2022	P2PR0134348	396-7270	PIN-GD	William Adam:
Bill	03/05/2022	P2PR0134348	396-7269	PIN-GD	William Adam:
Bill	03/05/2022	P2PR0134348	394-0220	BRG-THS	William Adam:
Bill	03/05/2022	P2PR0134348	380-7552	PIN-GD	William Adam:
Bill	03/05/2022	P2PR0134348	8W-4496	RETAINEI	William Adam:
Bill	03/05/2022	P2PR0134348	361-1695	BRG-SLV-	William Adam:
Bill	03/05/2022	P2PR0134348	102-1442	RETAINEF	William Adam:
Bill	03/05/2022	P2PR0134348	383-2140	BRG-SLV-	William Adam:
Bill	03/05/2022	P2PR0134348	425-3583	BRG-SLV	William Adam:
Bill	03/05/2022	P2PR0134348	383-2112	PIN-GD	William Adam:
Bill	04/05/2022	511166A	WASHER HITCH[BR]	ITR	Victoria
Bill	04/05/2022	511166A	WASHER HITCH	ITR	Victoria
Bill	04/05/2022	511166A	WASHER(STEEL - DRILLEI	ITR	Victoria
Bill	04/05/2022	511166A	WASHER	ITR	Victoria
Bill	04/05/2022	511166A	NUT 2-3/4 CASTLE UNF	ITR	Victoria
Bill	04/05/2022	P2PR0134944	384-4781 BRG-SLV-GD		William Adam:
Bill	04/05/2022	P2PR0134945	384-4781 BRG-SLV-GD		William Adam:
Bill	06/05/2022	IV00000001367	Liquid Nitrogen		MG Field & Er
Bill	06/05/2022	P2PR0136209	1D-4626 CAP SCREW		William Adam:
Bill	06/05/2022	P2PR0136209	5P-8249 WASHER-HARD		William Adam:
Bill	10/05/2022	P2PR0137423	380-7374 BRG-SLV-GD		William Adam:
Bill	10/05/2022	P2PR0137423	396-7270 PIN-GD		William Adam:
Bill	10/05/2022	P2PR0137423	396-7280 PIN-GD		William Adam:
Bill	11/05/2022	P2PR0138042	380-7378 BRG-SLV-GD		William Adam:
Bill	12/05/2022	P2PR0138693	380-7378 BRG-SLV-GD		William Adam:
Bill	19/05/2022	IV00000001375	Supply Liquid Nitrogen		MG Field & Er
Bill	19/05/2022	P2PR0141785	156-0931 AIR GUN		William Adam:
Bill	26/05/2022	P2PR0144697	165-3929 BOLT-HEX HEA		William Adam:
Bill	26/05/2022	P2PR0144697	8M-3175 WASHER		William Adam:
Bill	27/05/2022	P2PR0145271	2J-0564 NUT		William Adam:
Bill	27/05/2022	P2PR0145271	5J-4988 *SEAL A		William Adam:
Bill	27/05/2022	P2PR0145271	5P-8248 WASHER		William Adam:
Bill	27/05/2022	P2PR0145271	289-2937 *SEAL AS		William Adam:
Bill	27/05/2022	P2PR0145271	289-2948 *SEAL U		William Adam:
Bill	27/05/2022	P2PR0145271	225-3281 *SEAL-WIF		William Adam:
Bill	27/05/2022	P2PR0145271	2K-2961 *RING		William Adam:
Bill	27/05/2022	P2PR0145271	175-7905 *SEAL-O-f		William Adam:
Bill	27/05/2022	P2PR0145271	4J-4606 *RING		William Adam:
Bill	27/05/2022	P2PR0145271	8T-5668 *RING WE^		William Adam:
Bill	27/05/2022	P2PR0145271	3K-0360 *SEAL-O-R		William Adam:
Bill	27/05/2022	INV-40616	Bore And Machine Linkage F	TBAS	Precisic
Bill	27/05/2022	P2PR0145272	1A-8063 CAPSCREW		William Adam:
Bill	27/05/2022	P2PR0145277	8C-4436 BOLT		William Adam:
Bill	27/05/2022	P2PR0145277	8T-4223 WASHER		William Adam:
Bill	30/05/2022	P2PR0145936	8C-4436 BOLT		William Adam:
Bill	31/05/2022	00057747	Replace tube in cylinder,r		Hesco
Bill	09/06/2022	00011714	Operating and Envir Cost		Wimmera Mac
Bill	09/06/2022	00011714	Machine Torque Converter		Wimmera Mac
Bill	22/06/2022	P2PR0154830	2S-0795 *GASKET		William Adam:
Bill	22/06/2022	P2PR0154830	180-3907 *SEAL-INTEGRAL		William Adam:
Bill	23/06/2022	P2PR0155397	10R-3667 CORE AS OIL		William Adam:
Bill	23/06/2022	P2PR0155397	10R-3667 CORE DEPOSIT		William Adam:
Bill	28/07/2022	P2PR0169294	6G-0593 VALVE		William Adam:

Credit	15/09/2022	P3PR0012758	10R-3667 CORE RETURN	William Adam:
Bill	26/09/2022	P2PR0191652	1A-8063 CAPSCREW	William Adam:
Bill	13/10/2022	1881596	LEICA SUNDRIES	C R Kennedy ,
Bill	13/10/2022	1881596	LABOUR - SURVEY	C R Kennedy ,
Bill	13/10/2022	1881596	3G PCBA TESTED	C R Kennedy ,
Bill	26/10/2022	P2PR0203262	8T-0328 WASHER	William Adam:
Bill	27/10/2022	P2PR0203821	3B-4502 LOCKWASHER	William Adam:
Bill	27/10/2022	P2PR0203821	9X-6615 BOLT	William Adam:
Bill	28/10/2022	P2PR0204390	8Y-5911 ARMREST G	William Adam:
Bill	28/10/2022	P2PR0204390	8Y-5904 BASE-ARMREST	William Adam:
Bill	28/10/2022	P2PR0204390	283-4304 THUMB SCREW	William Adam:
Bill	28/10/2022	P2PR0204390	141-1489 ADAPTER	William Adam:
Bill	02/11/2022	P2PR0205436	3E-5239 *RELAY A	William Adam:
Bill	09/11/2022	P2PR0208173	4B-3388 CAP SCREW	William Adam:
Bill	09/11/2022	P2PR0208173	1T-0417 BOLT	William Adam:
Bill	09/11/2022	P2PR0208174	1T-0417 BOLT	William Adam:
Bill	11/11/2022	P2PR0208770	9H-6454 *GASKET	William Adam:
Bill	11/11/2022	P2PR0208770	4D-0306 *GASKET	William Adam:
Bill	11/11/2022	P2PR0208770	6F-5188 *GASKET	William Adam:
Bill	11/11/2022	P2PR0209237	4J-8251 *GROMMET	William Adam:
Bill	11/11/2022	P2PR0209237	4J-8252 *GAUGE-SIGHT H\	William Adam:
Bill	11/11/2022	P2PR0209237	4D-0306 *GASKET	William Adam:
Bill	14/11/2022	P2PR0209856	5J-3316 *GASKET	William Adam:
Bill	14/11/2022	P2PR0209856	4D-0306 *GASKET	William Adam:
Bill	15/11/2022	P2PR0210425	2R-1922 UNION	William Adam:
Bill	15/11/2022	P2PR0210425	8L-5008 ELBOW	William Adam:
Bill	15/11/2022	P2PR0210426	1T-0738 WASHER	William Adam:
Bill	16/11/2022	P2PR0210926	2R-1922 UNION	William Adam:
Bill	16/11/2022	P2PR0210926	8L-5008 ELBOW	William Adam:
Bill	01/12/2022	P2PR0217091	1K-6872 *NUT	William Adam:
Bill	01/12/2022	P2PR0217091	5P-1076 WASHER	William Adam:
Bill	01/12/2022	P2PR0217091	8T-4223 WASHER	William Adam:
Bill	01/12/2022	P2PR0217091	523-9432 PUMP AS-WSHL	William Adam:
Bill	02/12/2022	P2PR0217610	161-6963 CLAMP	William Adam:
Bill	02/12/2022	P2PR0217610	4V-9804 PLATE	William Adam:
Bill	02/12/2022	P2PR0217610	1B-2709 BOLT	William Adam:
Bill	02/12/2022	P2PR0217610	1D-4690 BOLT	William Adam:
Bill	02/12/2022	P2PR0217610	356-9931 SHAFT	William Adam:
Bill	02/12/2022	P2PR0217610	215-3579 SLEEVE	William Adam:
Bill	06/12/2022	P2PR0218839	267-2778 PLATE	William Adam:
Bill	06/12/2022	P2PR0218839	267-7539 *BELT	William Adam:
Bill	06/12/2022	P2PR0218839	279-6074 STEP AS	William Adam:
Bill	06/12/2022	P2PR0218839	1D-4687 BOLT	William Adam:
Bill	06/12/2022	P2PR0218839	480-6996 *GROMMET	William Adam:
Bill	20/12/2022	P2PR0224977	3B-4627 COTTER PIN	William Adam:
Bill	20/12/2022	P2PR0224977	7D-1649 WASHER	William Adam:
Bill	20/12/2022	P2PR0224977	8C-4436 BOLT	William Adam:
Bill	20/12/2022	P2PR0224977	8T-4223 WASHER	William Adam:
Bill	20/12/2022	P2PR0224977	8T-4994 WASHER	William Adam:
Bill	20/12/2022	P2PR0224977	8T-8917 BOLT	William Adam:
Bill	20/12/2022	P2PR0224977	8T-8920 BOLT	William Adam:
Bill	20/12/2022	P2PR0224977	8T-9393 BOLT	William Adam:
Bill	20/12/2022	P2PR0224977	201-2184 BOLT-HEX HEA	William Adam:
Bill	20/12/2022	P2PR0224977	8W-9517 SPACER	William Adam:
Bill	20/12/2022	P2PR0224977	3G-4434 PIN A	William Adam:
Bill	20/12/2022	P2PR0224977	365-1382 *KIT-SEAL-H.C	William Adam:

Bill	20/12/2022	P2PR0224977	399-4397 BRG-ALIGN-GD	William Adam:
Bill	20/12/2022	P2PR0224977	6V-8179 *RING	William Adam:
Bill	20/12/2022	P2PR0224772	4K-7463 *SEAL	William Adam:
Bill	20/12/2022	P2PR0224772	1K-6870 NUT	William Adam:
Bill	20/12/2022	P2PR0224772	3B-4627 COTTER PIN	William Adam:
Bill	20/12/2022	P2PR0224772	8T-4223 WASHER	William Adam:
Bill	20/12/2022	P2PR0224772	8T-4994 WASHER	William Adam:
Bill	20/12/2022	P2PR0224772	289-2937 *SEAL AS	William Adam:
Bill	20/12/2022	P2PR0224772	289-2948 *SEAL U	William Adam:
Bill	20/12/2022	P2PR0224772	225-3281 *SEAL-WIPER	William Adam:
Bill	20/12/2022	P2PR0224772	175-7905 *SEAL-O-RING	William Adam:
Bill	20/12/2022	P2PR0224772	4J-4606 *RING	William Adam:
Bill	20/12/2022	P2PR0224772	3K-0360 *SEAL-O-RING TY	William Adam:
Bill	20/12/2022	P2PR0224772	9S-4185 PLUG	William Adam:
Bill	21/12/2022	P2PR0225365	7J-8458 BEARING	William Adam:
Bill	21/12/2022	P2PR0225365	4J-5689 WASHER	William Adam:
Bill	21/12/2022	P2PR0225365	4J-5690 WASHER	William Adam:
Bill	21/12/2022	P2PR0225365	4J-5691 WASHER	William Adam:
Bill	21/12/2022	P2PR0225365	5T-4648 SHAFT	William Adam:
Bill	21/12/2022	P2PR0225365	5T-4649 SPACER	William Adam:
Bill	21/12/2022	P2PR0225365	102-1444 BEARING	William Adam:
Bill	21/12/2022	P2PR0225365	9J-2323 WASHER	William Adam:
Bill	21/12/2022	P2PR0225365	4J-5692 WASHER	William Adam:
Bill	21/12/2022	P2PR0225365	7J-3663 WASHER	William Adam:
Bill	21/12/2022	P2PR0225365	5T-8525 PLATE	William Adam:
Bill	21/12/2022	P2PR0225365	6V-8849 BOLT	William Adam:
Bill	21/12/2022	P2PR0225365	5J-4988 *SEAL A	William Adam:
Bill	21/12/2022	P2PR0225365	2K-2961 *RING	William Adam:
Bill	21/12/2022	P2PR0225365	8T-5668 *RING WEAR	William Adam:
Bill	21/12/2022	P2PR0225365	3G-4434 PIN A	William Adam:
Bill	21/12/2022	P2PR0225365	383-2124 PIN-GD	William Adam:
Bill	21/12/2022	P2PR0225365	8J-9910 BEARING	William Adam:
Bill	21/12/2022	P2PR0225585	5T-3323 PIN A	William Adam:
Bill	21/12/2022	P2PR0225585	8J-0632 PIN	William Adam:
Bill	21/12/2022	P2PR0225585	8J-7727 PIN	William Adam:
Bill	21/12/2022	P2PR0225585	148-3465 PIN	William Adam:
Bill	21/12/2022	P2PR0225585	4J-5692 WASHER	William Adam:
Bill	21/12/2022	P2PR0225585	6V-8849 BOLT	William Adam:
Bill	21/12/2022	P2PR0225585	7J-3663 WASHER	William Adam:
Bill	22/12/2022	P2PR0225936	361-1693 BRG-SLV-GD	William Adam:
Bill	22/12/2022	P2PR0225936	2J-5637 PIN	William Adam:
Bill	22/12/2022	P2PR0225936	9J-1676 BEARING	William Adam:
Bill	22/12/2022	P2PR0225936	380-7394 PIN AS-GD	William Adam:
Bill	22/12/2022	P2PR0225936	396-7270 PIN-GD	William Adam:
Bill	22/12/2022	P2PR0225936	396-7269 PIN-GD	William Adam:
Bill	22/12/2022	P2PR0225936	394-0220 BRG-THST-GD	William Adam:
Bill	22/12/2022	P2PR0225936	380-7552 PIN-GD	William Adam:
Bill	22/12/2022	P2PR0225936	361-1695 BRG-SLV-GD	William Adam:
Bill	22/12/2022	P2PR0225936	9J-2171 SPACER	William Adam:
Bill	22/12/2022	P2PR0225936	383-2140 BRG-SLV-GD	William Adam:
Bill	22/12/2022	P2PR0225936	425-3583 BRG-SLV-GD	William Adam:
Bill	22/12/2022	P2PR0225936	383-2112 PIN-GD	William Adam:
Bill	22/12/2022	P2PR0225936	5T-8525 PLATE	William Adam:
Bill	22/12/2022	P2PR0225936	384-4781 BRG-SLV-GD	William Adam:
Bill	22/12/2022	P2PR0225936	385-3790 BRG-SLV-GD	William Adam:
Bill	22/12/2022	P2PR0225936	379-0190 BRG-SLV-GD	William Adam:

Bill	22/12/2022	P2PR0225936	386-4922 BRG-SLV-GD	William Adam:
Bill	22/12/2022	P2PR0225936	380-7566 BRG-SLV-GD	William Adam:
Bill	04/01/2023	P2PR0227815	361-1692 BRG-SLV-GD	William Adam:
Bill	04/01/2023	P2PR0227815	394-0220 BRG-THST-GD	William Adam:
Bill	04/01/2023	P2PR0227815	396-7280 PIN-GD	William Adam:
Bill	16/01/2023	P2PR0232068	8F-8151 VALVE-SHUTOF	William Adam:
Bill	16/01/2023	P2PR0232068	471-0264 *WIRE AS	William Adam:
Bill	17/01/2023	P2PR0232642	339-9363 *SWITCH AS-CO	William Adam:
Bill	03/02/2023	559485A	Parts	ITR Victoria
Bill	06/02/2023	P2PR0240428	05C212775 Parts	William Adam:
Bill	06/02/2023	P2PR0240678	399-7947 *SEAT GP	William Adam:
Bill	06/02/2023	INV-0853	SOCKET 1/8 NPT	N.E Mechanic:
Bill	06/02/2023	INV-0853	SWIVEL STR FEM F/F O-RIN	N.E Mechanic:
Bill	06/02/2023	INV-0853	SWIVEL 90' FEM F/F O-RIN	N.E Mechanic:
Bill	06/02/2023	INV-0853	HOSE 1/2 XH HI-TEMP	N.E Mechanic:
Bill	06/02/2023	INV-0853	FERRULE BODY C1T/2AT/	N.E Mechanic:
Bill	07/02/2023	INV-13427	Clean and measure all bores	Chambers Poi
Bill	07/02/2023	P2PR0241083	05C212775A Parts	William Adam:
Bill	07/02/2023	P2PR0241084	05C212787 Parts	William Adam:
Bill	07/02/2023	P2PR0241085	05C212806 Parts	William Adam:
Bill	07/02/2023	P2PR0241086	05C212809 Parts	William Adam:
Bill	08/02/2023	P2PR0241697	8W-0265 TUBE A	William Adam:
Bill	08/02/2023	P2PR0241698	05C212787A Parts	William Adam:
Bill	08/02/2023	P2PR0241699	05C212806A Parts	William Adam:
Bill	08/02/2023	P2PR0241700	9F-7283 *RING	William Adam:
Bill	09/02/2023	P2PR0242282	5K-9246 FITTING	William Adam:
Bill	09/02/2023	P2PR0242283	179-3149 STUD-TAPERLO	William Adam:
Bill	09/02/2023	P2PR0242285	Repairs & Maintenance - SC	William Adam:
Bill	09/02/2023	P2PR0242284	4H-2686 *RING	William Adam:
Bill	10/02/2023	P2PR0242853	05C212857A Parts	William Adam:
Bill	10/02/2023	P2PR0242854	6J-2680 *SEAL O RING	William Adam:
Bill	13/02/2023	P2PR0243443	215-2866 GAUGE-XMSN O	William Adam:
Bill	13/02/2023	P2PR0243445	05C212881 Parts	William Adam:
Bill	14/02/2023	P2PR0244110	05C212881A Parts	William Adam:
Bill	15/02/2023	P2PR0244755	3G-6054 RETAINER	William Adam:
Bill	23/02/2023	P2PR0248405	05C213169 - Parts	William Adam:
Bill	24/02/2023	559485	BEARING HITCH	ITR Victoria
Bill	24/02/2023	P2PR0248992	05C213169A - Parts	William Adam:
Bill	27/02/2023	P2PR0249617	05C213193A - Parts	William Adam:
Bill	27/02/2023	P2PR0249619	05C213201A - parts	William Adam:
Bill	27/02/2023	P2PR0249620	05C213234 - parts	William Adam:
Bill	01/03/2023	P2PR0250907	05C213193B - parts	William Adam:
Bill	01/03/2023	P2PR0250909	05C213201B- parts	William Adam:
Bill	01/03/2023	P2PR0250914	05C213287	William Adam:
Bill	01/03/2023	P2PR0250913	05C213256A	William Adam:
Bill	09/03/2023	P2PR0254936	188-2461 VALVE GP-SOLEI	William Adam:
Bill	17/03/2023	P2PR0258050	294-3342 CAP AS-RAD	William Adam:
Bill	24/05/2023	47335	Check UHF Radio, repair br	David Carson
Bill	24/05/2023	47335	Benelec UHF Extension Spe	David Carson
Bill	24/05/2023	47335	GME SPK09 Extension Spe	David Carson
Credit	24/05/2023	P3PR0018861	SUSPENSION G	William Adam:
Bill	13/07/2023	P2PR0303703	*SWITCH GP-DISCONNEN	William Adam:
Bill	02/10/2023	P2PR0335041	05C216514A	William Adam:
Bill	03/10/2023	P2PR0335502	05C216514B	William Adam:
Bill	13/10/2023	P2PR0339716	445-9516 *CONT GP-HAND	William Adam:
Bill	16/10/2023	P2PR0340230	05C216767	William Adam:

Bill	17/10/2023	P2PR0340802	05C216767A	William Adam:
Bill	20/10/2023	P2PR0342406	05C216834A	William Adam:
Bill	23/10/2023	P2PR0342947	05C216834B	William Adam:
Bill	14/11/2023	P2PR0351034	05C217202A	William Adam:
Bill	15/11/2023	P2PR0351563	05C217202B	William Adam:
Bill	17/11/2023	P2PR0352687	05C217319	William Adam:
Bill	15/12/2023	P2PR0363756	05C217771	William Adam:
Bill	18/12/2023	P2PR0364365	05C217777	William Adam:
Bill	19/12/2023	P2PR0364962	338-1462 *SENSOR GP-PO	William Adam:
Bill	19/12/2023	P2PR0364962	284-3599 CAM-FREEWHEEL	William Adam:
Bill	19/12/2023	P2PR0364962	368-0297 PLATE	William Adam:
Bill	19/12/2023	P2PR0364962	3S-0040 PLATE	William Adam:
Bill	19/12/2023	P2PR0364962	3S-0044 PLATE	William Adam:
Bill	19/12/2023	P2PR0364962	05C217771A	William Adam:
Bill	21/12/2023	763169	Repairs & Maintenance - SC	Expressway S
Bill	21/12/2023	P2PR0366018	Repairs & Maintenance - SC	William Adam:
Bill	02/01/2024	P2PR0367402	Repairs & Maintenance - SC	William Adam:
Bill	02/01/2024	P2PR0367401	Repairs & Maintenance - SC	William Adam:
Bill	02/01/2024	P2PR0367404	Repairs & Maintenance - SC	William Adam:
Bill	03/01/2024	P2PR0367628	Repairs & Maintenance - SC	William Adam:
Bill	04/01/2024	P2PR0367947	Repairs & Maintenance - SC	William Adam:
Bill	12/01/2024	S2SR0060828	Repairs & Maintenance - SC	William Adam:
Bill	19/01/2024	INV-0951	Repairs & Maintenance - SC	N.E Mechanic:
Bill	25/01/2024	P2PR0375415	05C218193A	William Adam:
Bill	29/01/2024	P2PR0376056	05C218223	William Adam:
Bill	29/01/2024	P2PR0376057	05C218227	William Adam:
Bill	30/01/2024	P2PR0376483	0R-3366 CORE GP-OIL CLF	William Adam:
Bill	30/01/2024	P2PR0376483	0R-3366 CORE DEPOSIT	William Adam:
Bill	30/01/2024	P2PR0376483	05C218227A	William Adam:
Bill	31/01/2024	P2PR0377101	Repairs & Maintenance - SC	William Adam:
Bill	31/01/2024	INV-0243	Fabricate Transmission stan	MG Field & Er
Bill	01/02/2024	P2PR0377603	05C218263A	William Adam:
Bill	06/02/2024	S2SR062264	TEST TRANSMISSION ON	William Adam:
Credit	07/02/2024	P3PR0024942	0R-3366 CORE RETURN	William Adam:
Bill	09/02/2024	P2PR0381156	05C218419	William Adam:
Bill	12/02/2024	P2PR0381687	05C218438A	William Adam:
Bill	12/02/2024	P2PR0381685	5T-2283 PLATE A	William Adam:
Bill	12/02/2024	P2PR0381685	05C218419A	William Adam:
Bill	13/02/2024	P2PR0382202	6G-0389 SPIDER	William Adam:
Bill	13/02/2024	P2PR0382202	6G-0391 RETAINER	William Adam:
Bill	13/02/2024	P2PR0382202	6G-0399 SPRING	William Adam:
Bill	13/02/2024	P2PR0382202	Repairs & Maintenance - SC	William Adam:
Bill	13/02/2024	P2PR0382204	05C218439A	William Adam:
Bill	13/02/2024	P2PR0382205	05C218452A	William Adam:
Bill	13/02/2024	P2PR0382203	05C218438B	William Adam:
Bill	14/02/2024	P2PR0382712	05C218491	William Adam:
Bill	15/02/2024	P2PR0383242	05C218452B	William Adam:
Bill	15/02/2024	P2PR0383244	05C218491A	William Adam:
Credit	16/02/2024	P3PR0025148	05R018257	William Adam:
Bill	22/02/2024	P2PR0386029	05C218646	William Adam:
Bill	26/02/2024	P2PR0387222	05C218646A	William Adam:
Bill	05/03/2024	INV-0966	HOSE STRAP 800MM FRA	N.E Mechanic:
Credit	18/03/2024	P3PR00325764	0R-4783 CORE RETURN	William Adam:
Bill	22/03/2024	P2PR0397632	05C219088	William Adam:
Bill	25/03/2024	P2PR0398196	05C219122	William Adam:
Bill	25/03/2024	P2PR0398195	05C219088A	William Adam:

Bill	26/03/2024	P2PR0398763	05C219088B	William Adam:
Bill	27/03/2024	P2PR0399629	14C120608A	William Adam:
Bill	01/04/2024	INV-0985	4T series crimp	N.E Mechanic:
Bill	09/04/2024	P2PR0403374	05C219088C	William Adam:
Bill	23/04/2024	P2PR0409077	14C120608B	William Adam:
Bill	01/05/2024	INV-1004	HOSE GREASE FILLED 8.7	N.E Mechanic:
Bill	01/05/2024	INV-1004	CRS INLET SECTION M10	N.E Mechanic:
Bill	01/05/2024	INV-1004	CRS VALVE TWIN OUTPUT	N.E Mechanic:
Bill	01/05/2024	INV-1004	CRS VALVE TWIN OUTPUT	N.E Mechanic:
Bill	01/05/2024	INV-1004	CRS VALVE TWIN OUTPUT	N.E Mechanic:
Bill	01/05/2024	INV-1004	CRS VALVE TWIN OUTPUT	N.E Mechanic:
Bill	01/05/2024	INV-1004	CRS VALVE TWIN OUTPUT	N.E Mechanic:
Bill	01/05/2024	INV-1004	CRS VALVE TWIN OUTPUT	N.E Mechanic:
Bill	01/05/2024	INV-1004	CRS VALVE TWIN OUTPUT	N.E Mechanic:
Bill	01/05/2024	INV-1004	CRS VALVE TWIN OUTPUT	N.E Mechanic:
Bill	01/05/2024	INV-1004	CRS VALVE TWIN OUTPUT	N.E Mechanic:
Bill	01/05/2024	INV-1004	CRS END VALVE TWIN OU	N.E Mechanic:
Bill	25/06/2024	P2PR0430683	05C220286A - *HARNESS	William Adam:
Bill	03/07/2024	P2PR0434845	05C220504	William Adam:
Bill	09/07/2024	INV-1037	FERRULE SUIT G1 & G2	N.E Mechanic:
Bill	09/07/2024	INV-1037	SWIVEL STR FEM F/F O-R	N.E Mechanic:
Bill	09/07/2024	INV-1037	HOSE 1/4 N/SKIVE SAE100	N.E Mechanic:
Bill	09/07/2024	INV-1037	HOSE 1/2 N/SKIVE SAE100	N.E Mechanic:
Bill	09/07/2024	INV-1037	FERRULE BODY C1T/2AT/	N.E Mechanic:
Bill	09/07/2024	INV-1037	SWIVEL STR FEM F/F O-R	N.E Mechanic:
Bill	09/07/2024	INV-1037	STEM 90' FLGE CODE 61	N.E Mechanic:
Bill	09/07/2024	INV-1037	STEM FLGE CODE 61	N.E Mechanic:
Bill	09/07/2024	INV-1037	FERRULE NON/SKIVE M3K	N.E Mechanic:
Bill	09/07/2024	INV-1037	HOSE 1 " ID 4000 PSI	N.E Mechanic:
Bill	16/07/2024	651927	2ND HAND CAT 627 APROI	Charles Hull C
Bill	25/07/2024	P2PR0443176	05C220822	William Adam:
Bill	26/07/2024	P2PR0443620	05C220822A	William Adam:
Bill	26/07/2024	P2PR0443621	05C220841	William Adam:
Bill	29/07/2024	P2PR0444017	05C220822B	William Adam:
Bill	29/07/2024	P2PR0444018	05C220841A	William Adam:
Bill	29/07/2024	P2PR0444023	05C220878	William Adam:
Bill	29/07/2024	P2PR0444022	05C220867	William Adam:
Bill	30/07/2024	P2PR0444510	05C220841B	William Adam:
Bill	30/07/2024	P2PR0444515	05C220910	William Adam:
Bill	30/07/2024	P2PR0444513	05C220880	William Adam:
Bill	31/07/2024	P2PR0445203	05C220914	William Adam:
Bill	31/07/2024	P2PR0445201	05C220880A	William Adam:
Bill	31/07/2024	P2PR0445200	05C220878A	William Adam:
Bill	01/08/2024	P2PR0445677	05C220914A	William Adam:
Bill	02/08/2024	P2PR0446137	05C220950	William Adam:
Bill	05/08/2024	P2PR0446726	05C220950A	William Adam:
Bill	05/08/2024	P2PR0446727	05C220951A	William Adam:
Bill	09/08/2024	P2PR0448904	05C220867A	William Adam:
Bill	12/08/2024	P2PR0449404	05C221093	William Adam:
Bill	13/08/2024	P2PR0449925	05C221131	William Adam:
Bill	14/08/2024	P2PR0450479	05C221131A	William Adam:
Bill	16/08/2024	P2PR0451701	05C221143A	William Adam:
Bill	08/09/2024	INV-1050	SPIRAL GUARD 50MM BLA	N.E Mechanic:
Bill	08/09/2024	INV-1050	SPIRAL GUARD 40MM BLA	N.E Mechanic:
Bill	08/09/2024	INV-1050	CAP FF O-RING	N.E Mechanic:
Bill	08/09/2024	INV-1050	PLUG FF O-RING	N.E Mechanic:
Bill	19/09/2024	P2PR0463850	05C221653	William Adam:
Bill	19/09/2024	P2PR0463851	05C221655	William Adam:

Bill	20/09/2024	P2PR0464376	05C221655A	William Adam:
Bill	20/09/2024	P2PR0464375	05C221653A	William Adam:
Bill	24/09/2024	P2PR0465407	05C221653B	William Adam:
Bill	26/09/2024	P2PR0466540	05C221734	William Adam:
Bill	30/09/2024	P2PR0467218	05C221734A	William Adam:
Bill	01/10/2024	P2PR0467559	05C221777	William Adam:
Bill	01/10/2024	P2PR0467558	05C221734B	William Adam:
Bill	02/10/2024	P2PR0468078	05C221796	William Adam:
Bill	02/10/2024	P2PR0468077	05C221794	William Adam:
Bill	04/10/2024	P2PR0469071	05C221809	William Adam:
Bill	04/10/2024	INV-1069	Parts	N.E Mechanic:
Bill	07/10/2024	P2PR0469521	236-8761 MUFFLER AS	William Adam:
Bill	07/10/2024	P2PR0469521	P2PR0469521	William Adam:
Bill	08/10/2024	P2PR0470123	05C221866	William Adam:
Bill	09/10/2024	P2PR0470617	05C221850A	William Adam:
Bill	10/10/2024	P2PR0471204	05C221866A	William Adam:
Bill	10/10/2024	P2PR0471202	05C221850B	William Adam:
Bill	11/10/2024	P2PR0471740	05C221870A	William Adam:
Bill	16/10/2024	P2PR0473341	05C221969	William Adam:
Bill	17/10/2024	245103	1MTR 3/4 H/T ALL THREAD	Wimmera Bolt
Bill	17/10/2024	245103	3/4 UNC HEX NUT	Wimmera Bolt
Bill	17/10/2024	729652	TRUNNION BALL	ITR Victoria
Bill	17/10/2024	P2PR0473840	05C221976	William Adam:
Bill	17/10/2024	P2PR0473841	05C221979	William Adam:
Bill	18/10/2024	P2PR0474370	05C221979A	William Adam:
Bill	21/10/2024	P2PR0474993	05C221979B	William Adam:
Bill	24/10/2024	P2PR0476598	05C221979C	William Adam:
Bill	01/11/2024	P2PR0479934	05C222185	William Adam:
Bill	04/11/2024	P2PR0480386	05C222185A	William Adam:
Bill	06/11/2024	P2PR0480973	05C222185B	William Adam:
Bill	07/11/2024	P2PR0481477	05C222241	William Adam:
Bill	11/11/2024	INV-0471	Fabricate belly plate.	SB Engineerin
Bill	15/11/2024	INV-1088	SOCKET 1/8 NPT	N.E Mechanic:
Bill	15/11/2024	INV-1088	SOCKET 3/8 NPT	N.E Mechanic:
Bill	15/11/2024	INV-1088	NIPPLE 3/4 NPT X 1-1/16 JI	N.E Mechanic:
Bill	15/11/2024	INV-1088	NIPPLE SAE-BOSS X FF O-	N.E Mechanic:
Bill	15/11/2024	INV-1088	PLUG 3/8 NPTF	N.E Mechanic:
Bill	15/11/2024	INV-1088	ADAPTOR M/F 1/2NPTF X 3/8	N.E Mechanic:
Bill	15/11/2024	INV-1088	REDUCING BUSH 3/8 X 1/8	N.E Mechanic:
Bill	15/11/2024	INV-1088	ELBOW 90 M/F 13/16" FF O-	N.E Mechanic:
Bill	15/11/2024	INV-1088	90 Deg Elbow STOR*ORFS	N.E Mechanic:
Bill	15/11/2024	INV-1088	ELBOW 90 M/M 3/4UNO-13	N.E Mechanic:
Bill	15/11/2024	INV-1088	PLUG FF O-RING	N.E Mechanic:
Bill	15/11/2024	INV-1088	HOSE 1 " ID 4000 PSI	N.E Mechanic:
Bill	21/11/2024	P2PR0487040	05C222472	William Adam:
Bill	21/11/2024	P2PR0487234	14C125075	William Adam:
Bill	21/11/2024	P2PR0487235	14C125076	William Adam:
Bill	22/11/2024	INV-1083	FERRULE BODY C1T/2AT/(N.E Mechanic:
Bill	22/11/2024	INV-1083	STEM 45' FLGE CODE 61	N.E Mechanic:
Bill	22/11/2024	INV-1083	STEM 90' FLGE CODE 61	N.E Mechanic:
Bill	22/11/2024	INV-1083	HOSE HI TEMP 1-1/4 LONC	N.E Mechanic:
Bill	22/11/2024	INV-1083	HOSE 1-1/4" 4000 PSI	N.E Mechanic:
Bill	22/11/2024	INV-1091	FERRULE NON-SKIVE C12	N.E Mechanic:
Bill	22/11/2024	INV-1091	STEM 45' FLGE CODE 61	N.E Mechanic:
Bill	22/11/2024	INV-1091	HOSE 1-1/4" 4000 PSI	N.E Mechanic:
Bill	22/11/2024	INV-1091	FERRULE BODY C1T/2AT/(N.E Mechanic:

Bill	22/11/2024	INV-1091	STEM 90' FLGE CODE 61	N.E Mechanic:
Bill	22/11/2024	INV-1091	HOSE HI TEMP 1-1/4 LONC	N.E Mechanic:
Bill	05/12/2024	P2PR0492583	05C222652A	William Adam:
Bill	05/12/2024	P2PR0492585	05C222675	William Adam:
Bill	06/12/2024	P2PR0493091	05C222675A	William Adam:
Bill	09/12/2024	P2PR0493657	05C222675B - 381-2509 TE	William Adam:
Bill	10/12/2024	P2PR0494222	05C222703A	William Adam:
Bill	09/01/2025	P2PR0502350	SPACER	William Adam:
Bill	09/01/2025	P2PR0502350	WASHER	William Adam:
Bill	10/01/2025	P2PR0502791	PIN A	William Adam:
Bill	10/01/2025	P2PR0502791	Bearing	William Adam:
Bill	10/01/2025	P2PR0502791	Washer	William Adam:
Bill	23/01/2025	P2PR0507579	05C223243A	William Adam:
Bill	28/01/2025	P2PR0508833	*HOSE A	William Adam:
Bill	04/02/2025	P2PR0511550	05C223417	William Adam:
Bill	05/02/2025	P2PR0512182	05C223417A	William Adam:
Bill	06/02/2025	P2PR0512765	05C223462	William Adam:
Bill	07/02/2025	P2PR0513338	05C223462A	William Adam:
Bill	10/02/2025	P2PR0513949	05C223462B	William Adam:
Bill	25/02/2025	INV-0562	Repair cracks on SC09.	SB Engineerin
Bill	10/03/2025	P2PR0525452	14C126908B	William Adam:
Bill	14/03/2025	P2PR0527131	05C223968	William Adam:
Bill	17/03/2025	P2PR0527705	05C223968A	William Adam:
Bill	17/04/2025	P2PR0540313	SWITCH A	William Adam:
Bill	25/04/2025	P2PR0541795	FILTER AS-LU	William Adam:
Bill	25/04/2025	P2PR0541795	FILTER A-FUE	William Adam:
Bill	25/04/2025	P2PR0541795	FILTER	William Adam:
Bill	25/04/2025	P2PR0541796	ELEMENT A-F	William Adam:
Bill	27/04/2025	INV-1145	FERRULE NON/SKIVE M3K	N.E Mechanic:
Bill	27/04/2025	INV-1145	STEM FLGE CODE 61	N.E Mechanic:
Bill	27/04/2025	INV-1145	STEM 90' FLGE CODE 61	N.E Mechanic:
Bill	27/04/2025	INV-1145	HOSE 1 " ID 4000 PSI	N.E Mechanic:
Bill	07/05/2025	P2PR0546040	05C224776A	William Adam:
Bill	08/05/2025	P2PR0546563	05C224776B	William Adam:
Bill	13/05/2025	P2PR0548412	05C224865	William Adam:
Bill	15/05/2025	P2PR0549534	05C224929	William Adam:
Bill	20/05/2025	P2PR0551123	05C224965A	William Adam:
Bill	03/06/2025	P2PR0556378	05C225170	William Adam:
Bill	11/06/2025	P2PR0558972	05C225291	William Adam:
Bill	13/06/2025	P2PR0560017	TENSIONER	William Adam:
Bill	16/06/2025	P2PR056025	9W-7385 SLEEVE	William Adam:
Bill	17/06/2025	2241645	Leica MMB1300 Cradle for iC R Kennedy	
Bill	17/06/2025	P2PR0561004	05C225319B	William Adam:
Bill	20/06/2025	P2PR0562555	05C225373A	William Adam:
Bill	26/06/2025	P2PR0564782	SEAL, VALVE, SEAL O-RIN	William Adam:
Bill	27/06/2025	P2PR0565257	Cap, Adapter, Valve, Seal, C	William Adam:

Bill	04/05/2018	328021477	Goodyear 33.25R29: TL-3A	Goodyear Ear
Bill	14/05/2021	366602	Repair as per report reskin	Tyre Doctor
Bill	22/03/2023	90216487	33.25R29 Scraper Tyres	Bridgestone E
Bill	27/06/2024	90306083	3325R29 Tyre	Bridgestone E

Bill

27/06/2024

90306066

3325R29 Tyre

Bridgestone E

Amount

	2,150.00
Crane Hire Pty	190.91
s Pty Ltd	11.25
s Pty Ltd	56.65
s Pty Ltd	4,473.61
s Pty Ltd	729.73
s Pty Ltd	306.42
s Pty Ltd	132.60
s Pty Ltd	154.23
Electronics P/l	(29.96)
s Pty Ltd	263.67
s Pty Ltd	107.05
s Pty Ltd	525.60
s Pty Ltd	92.76
o Electrical Pty	568.18
s Pty Ltd	223.12
s Pty Ltd	48.58
s Pty Ltd	87.34
s Pty Ltd	40.77
s Pty Ltd	7.58
s Pty Ltd	50.39
s Pty Ltd	613.38
s Pty Ltd	383.18
s Pty Ltd	308.60
s Pty Ltd	166.24
s Pty Ltd	1,133.65
s Pty Ltd	1,539.82
Electronics P/l	391.82
o Electrical Pty	100.00
o Electrical Pty	223.18
t	44.54
Crane Hire Pty	254.55
on Engineering	165.66
s Pty Ltd	32.50
s Pty Ltd	170.67
s Pty Ltd	464.67
Mildura	54.32
ners	36.76
o Electrical Pty	521.82
s Pty Ltd	45.36
s Pty Ltd	1.34
s Pty Ltd	26.67
s Pty Ltd	86.41
ing	10,980.00
s Pty Ltd	54.88
s Pty Ltd	27.18
s Pty Ltd	273.08
s Pty Ltd	510.49

s Pty Ltd	87.42
o Electrical Pty	140.00
ing	250.00
istries Pty Ltd	412.50
istries Pty Ltd	4,006.60
istries Pty Ltd	165.00
s Pty Ltd	105.16
Centre	24.11
s Pty Ltd	413.79
on Engineering	281.70
s Pty Ltd	92.28
on Engineering	190.00
s Pty Ltd	198.51
s Pty Ltd	47.91
dfacing & Wea	112.00
s Pty Ltd	26.97
o Electrical Pty	463.64
all	420.00
s Pty Ltd	125.56
s Pty Ltd	2,697.00
s Pty Ltd	112.01
s Pty Ltd	255.20
s Pty Ltd	134.33
s Pty Ltd	65.96
Centre	74.82
inics Pty Ltd	742.90
inics Pty Ltd	487.50
s Pty Ltd	991.48
s Pty Ltd	69.06
s Pty Ltd	59.46
s Pty Ltd	6.05
s Pty Ltd	470.72
s Pty Ltd	526.65
s Pty Ltd	296.26
s Pty Ltd	200.46
s Pty Ltd	0.28
s Pty Ltd	2,153.00
s Pty Ltd	2,858.98
s Pty Ltd	27.07
s Pty Ltd	13.67
s Pty Ltd	70.05
s Pty Ltd	285.03
s Pty Ltd	316.31
s Pty Ltd	432.15
s Pty Ltd	24.50
s Pty Ltd	329.40
s Pty Ltd	39.24
s Pty Ltd	328.43
s Pty Ltd	948.93
s Pty Ltd	1,296.45
s Pty Ltd	13.48
s Pty Ltd	621.88
Centre	152.18
Centre	37.23
Centre	110.98
s Pty Ltd	25.09

s Pty Ltd	52.38
s Pty Ltd	330.00
s Pty Ltd	9.90
s Pty Ltd	127.34
s Pty Ltd	24.56
s Pty Ltd	314.06
s Pty Ltd	4.64
s Pty Ltd	3.04
s Pty Ltd	7.50
s Pty Ltd	12.76
s Pty Ltd	3.62
s Pty Ltd	127.34
s Pty Ltd	50.48
s Pty Ltd	77.44
s Pty Ltd	58.96
s Pty Ltd	2,742.84
s Pty Ltd	(1,728.60)
s Pty Ltd	157.75
s Pty Ltd	1.42
s Pty Ltd	14.70
s Pty Ltd	1.68
s Pty Ltd	1.96
s Pty Ltd	8.47
s Pty Ltd	47.94
s Pty Ltd	436.10
s Pty Ltd	356.77
s Pty Ltd	135.20
s Pty Ltd	6.75
s Pty Ltd	1.68
s Pty Ltd	8.47
s Pty Ltd	792.71
s Pty Ltd	46.42
s Pty Ltd	(356.77)
s Pty Ltd	72.48
s Pty Ltd	3.91
s Pty Ltd	3.48
s Pty Ltd	185.92
s Pty Ltd	50.00
s Pty Ltd	75.16
s Pty Ltd	662.93
s Pty Ltd	113.42
s Pty Ltd	79.23
s Pty Ltd	1.06
s Pty Ltd	36.72
s Pty Ltd	17.34
s Pty Ltd	1.06
s Pty Ltd	50.00
s Pty Ltd	18.87
s Pty Ltd	0.92
s Pty Ltd	28.50
s Pty Ltd	13.85
s Pty Ltd	0.92
s Pty Ltd	50.00
s Pty Ltd	23.70
s Pty Ltd	37.86
s Pty Ltd	77.44

s Pty Ltd	46.82
s Pty Ltd	36.43
s Pty Ltd	0.93
s Pty Ltd	202.26
s Pty Ltd	76.52
s Pty Ltd	42.08
s Pty Ltd	14.50
s Pty Ltd	17.00
s Pty Ltd	689.49
s Pty Ltd	64.18
s Pty Ltd	267.35
s Pty Ltd	42.39
s Pty Ltd	42.39
s Pty Ltd	76.48
s Pty Ltd	68.64
s Pty Ltd	2,312.32
s Pty Ltd	16.80
s Pty Ltd	35.28
s Pty Ltd	20.42
s Pty Ltd	618.31
s Pty Ltd	15.87
s Pty Ltd	0.96
s Pty Ltd	19.47
s Pty Ltd	130.38
s Pty Ltd	209.04
s Pty Ltd	29.43
s Pty Ltd	3.00
s Pty Ltd	56.22
s Pty Ltd	182.88
s Pty Ltd	49.98
s Pty Ltd	2.52
s Pty Ltd	15.87
s Pty Ltd	8.46
s Pty Ltd	1.92
s Pty Ltd	158.88
s Pty Ltd	2.88
s Pty Ltd	176.23
s Pty Ltd	119.59
s Pty Ltd	237.21
s Pty Ltd	176.41
s Pty Ltd	1.65
s Pty Ltd	491.88
ing Services	1,250.00
s Pty Ltd	20.42
s Pty Ltd	2.88
s Pty Ltd	58.92
s Pty Ltd	176.41
s Pty Ltd	8.46
s Pty Ltd	1.36
s Pty Ltd	56.22
s Pty Ltd	1.65
s Pty Ltd	2.52
s Pty Ltd	32.58
s Pty Ltd	5.34
s Pty Ltd	462.39
s Pty Ltd	175.33

s Pty Ltd	17.66
s Pty Ltd	55.68
s Pty Ltd	2.06
s Pty Ltd	83.40
s Pty Ltd	82.42
s Pty Ltd	13.99
s Pty Ltd	4.57
s Pty Ltd	490.50
s Pty Ltd	8.88
s Pty Ltd	59.26
s Pty Ltd	42.82
s Pty Ltd	105.44
s Pty Ltd	9.30
s Pty Ltd	13.43
s Pty Ltd	14.72
s Pty Ltd	96.28
s Pty Ltd	319.61
s Pty Ltd	273.49
s Pty Ltd	97.38
s Pty Ltd	23.13
s Pty Ltd	78.03
s Pty Ltd	58.64
s Pty Ltd	2.16
s Pty Ltd	1.26
	69.96
	44.73
	20.00
s Pty Ltd	1.80
s Pty Ltd	104.81
s Pty Ltd	18.80
s Pty Ltd	8.62
s Pty Ltd	17.17
s Pty Ltd	299.16
s Pty Ltd	85.46
s Pty Ltd	0.50
s Pty Ltd	65.60
s Pty Ltd	20.80
s Pty Ltd	186.44
s Pty Ltd	30.36
s Pty Ltd	15.72
s Pty Ltd	158.61
s Pty Ltd	10.75
s Pty Ltd	35.44
s Pty Ltd	493.20
s Pty Ltd	32.18
s Pty Ltd	247.60
s Pty Ltd	21.43
s Pty Ltd	2.73
s Pty Ltd	89.62
s Pty Ltd	66.50
s Pty Ltd	120.00
s Pty Ltd	1.40
s Pty Ltd	14.61
s Pty Ltd	4.12
s Pty Ltd	42.86
s Pty Ltd	847.56

s Pty Ltd	6.98
s Pty Ltd	27.34
s Pty Ltd	23.24
s Pty Ltd	19.82
s Pty Ltd	34.46
s Pty Ltd	184.10
s Pty Ltd	46.55
s Pty Ltd	214.32
s Pty Ltd	5.99
s Pty Ltd	34.52
s Pty Ltd	11.12
s Pty Ltd	63.60
s Pty Ltd	93.29
s Pty Ltd	3.72
s Pty Ltd	8.26
s Pty Ltd	31.14
s Pty Ltd	22.90
s Pty Ltd	24.24
s Pty Ltd	5.27
s Pty Ltd	11.31
s Pty Ltd	196.49
s Pty Ltd	4.11
s Pty Ltd	5.40
s Pty Ltd	4.11
s Pty Ltd	88.34
s Pty Ltd	229.31
s Pty Ltd	41.13
. Equipment Pz	150.00
. Equipment Pz	132.00
. Equipment Pz	238.00
. Equipment Pz	207.50
. Equipment Pz	624.00
. Equipment Pz	180.00
. Equipment Pz	18.00
. Equipment Pz	32.50
. Equipment Pz	40.00
. Equipment Pz	128.00
. Equipment Pz	60.00
. Equipment Pz	3.50
. Equipment Pz	29.00
. Equipment Pz	52.00
. Equipment Pz	220.00
. Equipment Pz	95.00
. Equipment Pz	160.00
. Equipment Pz	115.00
. Equipment Pz	110.00
. Equipment Pz	110.00
. Equipment Pz	50.00
. Equipment Pz	360.00
. Equipment Pz	0.13
. Equipment Pz	254.00
. Equipment Pz	209.00
. Equipment Pz	98.00
. Equipment Pz	46.80
. Equipment Pz	46.40
. Equipment Pz	450.00

Equipment Pz	124.50
Equipment Pz	17.50
s Pty Ltd	18.08
s Pty Ltd	64.15
s Pty Ltd	18.08
s Pty Ltd	88.24
s Pty Ltd	194.88
s Pty Ltd	542.80
s Pty Ltd	167.34
s Pty Ltd	81.34
s Pty Ltd	49.44
s Pty Ltd	801.92
s Pty Ltd	88.24
s Pty Ltd	74.60
s Pty Ltd	136.46
on Engineering	2,250.00
s Pty Ltd	3.92
s Pty Ltd	6.20
s Pty Ltd	5.12
s Pty Ltd	1,191.14
s Pty Ltd	653.32
s Pty Ltd	14.93
s Pty Ltd	72.76
s Pty Ltd	104.51
s Pty Ltd	59.20
s Pty Ltd	218.28
s Pty Ltd	260.58
s Pty Ltd	33.12
s Pty Ltd	149.96
s Pty Ltd	72.88
s Pty Ltd	2.53
s Pty Ltd	4.36
s Pty Ltd	32.85
s Pty Ltd	4.70
s Pty Ltd	62.00
s Pty Ltd	14.57
s Pty Ltd	17.47
s Pty Ltd	111.34
s Pty Ltd	1.20
s Pty Ltd	(1,131.58)
s Pty Ltd	58.75
s Pty Ltd	2,060.36
s Pty Ltd	178.02
s Pty Ltd	30.04
s Pty Ltd	109.12
s Pty Ltd	73.20
s Pty Ltd	22.16
s Pty Ltd	24.61
s Pty Ltd	179.52
s Pty Ltd	44.88
s Pty Ltd	44.88
s Pty Ltd	(349.55)
s Pty Ltd	(109.12)
s Pty Ltd	(73.20)
s Pty Ltd	(22.16)
s Pty Ltd	(218.28)

s Pty Ltd	(58.21)
on Engineering	110.00
s Pty Ltd	494.72
s Pty Ltd	116.94
s Pty Ltd	111.18
s Pty Ltd	111.52
s Pty Ltd	144.63
s Pty Ltd	(46.55)
s Pty Ltd	4.50
s Pty Ltd	856.49
s Pty Ltd	891.47
s Pty Ltd	1.82
s Pty Ltd	0.64
s Pty Ltd	21.71
s Pty Ltd	596.35
s Pty Ltd	728.87
s Pty Ltd	1.76
s Pty Ltd	4.86
s Pty Ltd	5.96
s Pty Ltd	1.52
s Pty Ltd	60.61
s Pty Ltd	3.39
s Pty Ltd	15.95
s Pty Ltd	38.80
s Pty Ltd	155.58
s Pty Ltd	776.31
s Pty Ltd	808.00
s Pty Ltd	209.85
s Pty Ltd	16.08
s Pty Ltd	11.40
s Pty Ltd	16.97
s Pty Ltd	7.62
s Pty Ltd	2.46
s Pty Ltd	9.86
s Pty Ltd	1,661.83
s Pty Ltd	717.72
s Pty Ltd	991.12
s Pty Ltd	2.76
s Pty Ltd	25.18
s Pty Ltd	5.79
s Pty Ltd	7.24
s Pty Ltd	8.40
s Pty Ltd	11.80
s Pty Ltd	19.36
s Pty Ltd	1.48
s Pty Ltd	3.40
s Pty Ltd	4.26
s Pty Ltd	13.46
s Pty Ltd	7.58
s Pty Ltd	(728.87)
s Pty Ltd	(991.12)
s Pty Ltd	(891.47)
s Pty Ltd	2,971.69
s Pty Ltd	1.34
s Pty Ltd	4.54
s Pty Ltd	22.58

s Pty Ltd	4.54
s Pty Ltd	3.78
s Pty Ltd	1.34
s Pty Ltd	115.20
s Pty Ltd	254.32
s Pty Ltd	1.64
s Pty Ltd	2.56
s Pty Ltd	3.18
s Pty Ltd	17.08
s Pty Ltd	13.12
s Pty Ltd	25.37
s Pty Ltd	19.80
s Pty Ltd	58.71
s Pty Ltd	63.06
s Pty Ltd	153.25
s Pty Ltd	21.80
s Pty Ltd	185.77
s Pty Ltd	45.00
s Pty Ltd	12.00
s Pty Ltd	16.00
s Pty Ltd	260.00
s Pty Ltd	(153.25)
s Pty Ltd	(185.77)
s Pty Ltd	2,971.69
s Pty Ltd	93.97
s Pty Ltd	46.42
s Pty Ltd	9.99
s Pty Ltd	4.76
s Pty Ltd	25.16
s Pty Ltd	67.92
s Pty Ltd	5.15
s Pty Ltd	40.31
s Pty Ltd	36.34
s Pty Ltd	33.85
s Pty Ltd	0.88
s Pty Ltd	3.39
s Pty Ltd	26.88
s Pty Ltd	31.46
s Pty Ltd	230.53
s Pty Ltd	2.08
s Pty Ltd	21.76
s Pty Ltd	27.52
s Pty Ltd	29.12
s Pty Ltd	23.22
s Pty Ltd	24.36
s Pty Ltd	22.26
s Pty Ltd	714.97
s Pty Ltd	229.10
s Pty Ltd	222.49
s Pty Ltd	375.00
s Pty Ltd	11.25
s Pty Ltd	55.95
s Pty Ltd	27.33
s Pty Ltd	27.36
s Pty Ltd	49.75
s Pty Ltd	4.48

s Pty Ltd	7.17
s Pty Ltd	6.41
s Pty Ltd	106.18
s Pty Ltd	0.62
s Pty Ltd	1.79
s Pty Ltd	0.78
s Pty Ltd	0.71
s Pty Ltd	22.98
s Pty Ltd	22.98
s Pty Ltd	33.04
s Pty Ltd	27.90
s Pty Ltd	20.16
s Pty Ltd	31.12
s Pty Ltd	29.14
s Pty Ltd	29.42
s Pty Ltd	83.74
s Pty Ltd	87.10
s Pty Ltd	21.40
s Pty Ltd	31.56
s Pty Ltd	31.81
s Pty Ltd	9.42
nners	10.90
s Pty Ltd	8.19
s Pty Ltd	7.12
s Pty Ltd	233.69
s Pty Ltd	3.26
nners	149.25
nners	10.90
s and Access	247.50
s Pty Ltd	51.74
s Pty Ltd	3.14
s Pty Ltd	1.28
s Pty Ltd	85.90
s Pty Ltd	71.64
	0.71
	0.31
	0.86
	0.16
s Pty Ltd	34.03
s Pty Ltd	5.00
	1.32
s Pty Ltd	30.24
s Pty Ltd	16.10
on Engineering	37.00
s Pty Ltd	24.02
s Pty Ltd	469.06
s Pty Ltd	30.30
s Pty Ltd	61.56
s Pty Ltd	53.38
s Pty Ltd	59.84
inics Pty Ltd	100.00
s Pty Ltd	53.12
s Pty Ltd	45.32
s Pty Ltd	38.54
s Pty Ltd	66.98
s Pty Ltd	5.90

s Pty Ltd	5.13
s Pty Ltd	1.87
s Pty Ltd	6.11
s Pty Ltd	6.41
s Pty Ltd	11.01
s Pty Ltd	45.91
s Pty Ltd	4.14
s Pty Ltd	5.61
s Pty Ltd	41.80
s Pty Ltd	6.88
s Pty Ltd	4.59
s Pty Ltd	44.30
s Pty Ltd	36.18
s Pty Ltd	6.96
s Pty Ltd	217.00
s Pty Ltd	62.00
s Pty Ltd	12.38
s Pty Ltd	53.12
s Pty Ltd	45.32
s Pty Ltd	38.54
s Pty Ltd	66.98
s Pty Ltd	5.90
s Pty Ltd	5.13
s Pty Ltd	1.87
s Pty Ltd	6.11
s Pty Ltd	6.41
s Pty Ltd	11.01
s Pty Ltd	45.91
s Pty Ltd	70.81
s Pty Ltd	4.14
s Pty Ltd	5.61
s Pty Ltd	41.80
s Pty Ltd	6.88
s Pty Ltd	4.59
s Pty Ltd	40.24
s Pty Ltd	67.70
s Pty Ltd	37.36
s Pty Ltd	44.30
s Pty Ltd	36.18
s Pty Ltd	6.96
s Pty Ltd	217.00
s Pty Ltd	62.00
s Pty Ltd	12.38
ing (Aust)	83.52
s Pty Ltd	59.20
s Pty Ltd	82.06
s Pty Ltd	80.72
s Pty Ltd	174.16
s Pty Ltd	59.20
s Pty Ltd	82.06
s Pty Ltd	70.81
s Pty Ltd	80.72
s Pty Ltd	40.24
s Pty Ltd	67.70
s Pty Ltd	37.36
s Pty Ltd	168.34

s Pty Ltd	174.16
s Pty Ltd	343.27
s Pty Ltd	213.28
s Pty Ltd	21.13
s Pty Ltd	149.74
s Pty Ltd	80.31
s Pty Ltd	203.14
s Pty Ltd	17.29
s Pty Ltd	2.48
s Pty Ltd	2.08
s Pty Ltd	65.00
s Pty Ltd	343.27
s Pty Ltd	384.60
s Pty Ltd	12.66
s Pty Ltd	35.76
s Pty Ltd	2.32
s Pty Ltd	14.56
s Pty Ltd	8.08
s Pty Ltd	44.11
s Pty Ltd	70.00
s Pty Ltd	7.14
s Pty Ltd	6.90
s Pty Ltd	6.06
s Pty Ltd	0.62
s Pty Ltd	8.76
s Pty Ltd	6.24
s Pty Ltd	88.47
s Pty Ltd	5.04
s Pty Ltd	13.98
s Pty Ltd	3.90
s Pty Ltd	5.71
s Pty Ltd	430.28
s Pty Ltd	41.82
s Pty Ltd	37.86
s Pty Ltd	34.76
s Pty Ltd	8.49
s Pty Ltd	8.01
s Pty Ltd	21.99
s Pty Ltd	24.24
s Pty Ltd	5.61
s Pty Ltd	60.68
s Pty Ltd	82.78
g & Electrical	46.59
s Pty Ltd	424.21
ngineering	1,931.82
ngineering	309.09
s Pty Ltd	565.61
s Pty Ltd	2.78
s Pty Ltd	2.67
s Pty Ltd	1.39
s Pty Ltd	3.42
s Pty Ltd	19.36
s Pty Ltd	4.65
s Pty Ltd	7.39
s Pty Ltd	9.80
s Pty Ltd	25.12

s Pty Ltd	25.53
s Pty Ltd	12.91
s Pty Ltd	204.78
s Pty Ltd	4.96
s Pty Ltd	12.88
s Pty Ltd	10.52
s Pty Ltd	53.58
s Pty Ltd	5.85
al Services Pty	207.60
al Services Pty	5.79
al Services Pty	13.50
al Services Pty	172.80
s Pty Ltd	39.28
s Pty Ltd	190.84
s Pty Ltd	17.38
s Pty Ltd	25.34
s Pty Ltd	14.30
s Pty Ltd	17.52
s Pty Ltd	90.60
s Pty Ltd	6.08
s Pty Ltd	141.82
s Pty Ltd	5.00
s Pty Ltd	1,061.26
s Pty Ltd	7.58
s Pty Ltd	7.36
s Pty Ltd	9.07
s Pty Ltd	22.00
s Pty Ltd	1.86
s Pty Ltd	7.60
s Pty Ltd	304.89
s Pty Ltd	12.56
s Pty Ltd	3.76
s Pty Ltd	2,677.15
s Pty Ltd	3.75
s Pty Ltd	25.74
s Pty Ltd	12.79
s Pty Ltd	101.00
s Pty Ltd	21.37
s Pty Ltd	48.40
s Pty Ltd	28.32
s Pty Ltd	13.47
s Pty Ltd	18.33
s Pty Ltd	2.76
s Pty Ltd	31.30
s Pty Ltd	6.70
s Pty Ltd	6.30
s Pty Ltd	1.08
s Pty Ltd	6.20
s Pty Ltd	14.28
s Pty Ltd	3.90
s Pty Ltd	33.08
s Pty Ltd	5.22
s Pty Ltd	3.18
s Pty Ltd	68.58
s Pty Ltd	20.79
s Pty Ltd	3.34

s Pty Ltd	6.00
s Pty Ltd	3.76
s Pty Ltd	12.90
s Pty Ltd	16.77
s Pty Ltd	103.93
s Pty Ltd	8.00
s Pty Ltd	10.68
s Pty Ltd	29.28
s Pty Ltd	3.13
s Pty Ltd	6.68
s Pty Ltd	30.00
s Pty Ltd	33.08
s Pty Ltd	10.74
s Pty Ltd	6.93
s Pty Ltd	549.00
s Pty Ltd	9.39
s Pty Ltd	41.54
s Pty Ltd	33.08
s Pty Ltd	14.96
s Pty Ltd	36.06
s Pty Ltd	18.62
al Services Pty	37.40
al Services Pty	75.24
al Services Pty	65.52
al Services Pty	8.10
al Services Pty	38.52
al Services Pty	21.42
al Services Pty	42.75
al Services Pty	244.89
al Services Pty	21.42
al Services Pty	42.21
al Services Pty	22.68
s Pty Ltd	19.36
s Pty Ltd	19.20
s Pty Ltd	845.11
s Pty Ltd	862.00
s Pty Ltd	5.71
s Pty Ltd	144.56
s Pty Ltd	131.14
s Pty Ltd	6.22
s Pty Ltd	100.60
s Pty Ltd	1.57
s Pty Ltd	150.76
s Pty Ltd	174.38
s Pty Ltd	58.82
s Pty Ltd	156.58
s Pty Ltd	78.81
s Pty Ltd	8.86
s Pty Ltd	(344.78)
s Pty Ltd	63.38
s Pty Ltd	4.43
s Pty Ltd	62.24
s Pty Ltd	313.61
s Pty Ltd	272.29
s Pty Ltd	37.38
s Pty Ltd	156.58

s Pty Ltd	12.46
s Pty Ltd	15.84
s Pty Ltd	76.00
s Pty Ltd	33.45
s Pty Ltd	30.00
s Pty Ltd	417.98
s Pty Ltd	316.98
s Pty Ltd	27.52
s Pty Ltd	63.34
s Pty Ltd	12.60
s Pty Ltd	48.26
s Pty Ltd	52.60
s Pty Ltd	38.60
s Pty Ltd	33.57
s Pty Ltd	17.85
s Pty Ltd	10.39
s Pty Ltd	2.56
s Pty Ltd	162.14
s Pty Ltd	367.85
s Pty Ltd	29.86
s Pty Ltd	73.86
s Pty Ltd	190.47
s Pty Ltd	5.36
s Pty Ltd	10.39
s Pty Ltd	14.65
s Pty Ltd	266.51
s Pty Ltd	132.92
s Pty Ltd	1,162.00
s Pty Ltd	660.00
s Pty Ltd	58.10
s Pty Ltd	12.26
s Pty Ltd	1.85
s Pty Ltd	78.89
s Pty Ltd	3.81
s Pty Ltd	48.52
s Pty Ltd	4.11
s Pty Ltd	7.13
s Pty Ltd	33.50
s Pty Ltd	39.78
s Pty Ltd	38.40
s Pty Ltd	29.52
s Pty Ltd	188.88
s Pty Ltd	96.36
s Pty Ltd	53.30
s Pty Ltd	134.16
s Pty Ltd	53.78
s Pty Ltd	2,178.54
s Pty Ltd	889.83
s Pty Ltd	149.06
s Pty Ltd	153.16
s Pty Ltd	245.45
s Pty Ltd	71.12
s Pty Ltd	1.92
s Pty Ltd	1.42
s Pty Ltd	4.85
s Pty Ltd	11.24

s Pty Ltd	13.96
s Pty Ltd	29.58
s Pty Ltd	21.39
s Pty Ltd	25.76
s Pty Ltd	55.00
s Pty Ltd	61.12
s Pty Ltd	10.29
s Pty Ltd	30.75
s Pty Ltd	1.42
s Pty Ltd	1.52
s Pty Ltd	3.08
s Pty Ltd	14.34
s Pty Ltd	4.00
s Pty Ltd	5.83
s Pty Ltd	38.40
s Pty Ltd	5.64
s Pty Ltd	53.30
s Pty Ltd	5.03
s Pty Ltd	5.07
s Pty Ltd	4.36
s Pty Ltd	5.99
s Pty Ltd	16.92
s Pty Ltd	24.15
s Pty Ltd	11.12
s Pty Ltd	6.58
s Pty Ltd	27.04
s Pty Ltd	0.58
s Pty Ltd	1.86
s Pty Ltd	11.72
s Pty Ltd	10.88
s Pty Ltd	36.74
s Pty Ltd	14.74
s Pty Ltd	211.89
s Pty Ltd	63.61
s Pty Ltd	248.48
s Pty Ltd	3.83
s Pty Ltd	17.28
s Pty Ltd	22.00
s Pty Ltd	18.05
s Pty Ltd	15.90
s Pty Ltd	3.81
s Pty Ltd	4.85
s Pty Ltd	55.00
s Pty Ltd	13.02
s Pty Ltd	36.35
s Pty Ltd	77.12
s Pty Ltd	2.76
s Pty Ltd	0.34
s Pty Ltd	106.18
s Pty Ltd	1,010.93
s Pty Ltd	620.00
s Pty Ltd	36.88
s Pty Ltd	3.90
s Pty Ltd	8.16
s Pty Ltd	3.90
s Pty Ltd	172.15

s Pty Ltd	4.72
s Pty Ltd	64.83
s Pty Ltd	50.07
s Pty Ltd	3.14
s Pty Ltd	53.42
s Pty Ltd	29.79
s Pty Ltd	8.33
s Pty Ltd	4.78
s Pty Ltd	38.42
s Pty Ltd	35.44
s Pty Ltd	104.31
s Pty Ltd	73.39
s Pty Ltd	61.85
s Pty Ltd	123.55
s Pty Ltd	12.12
s Pty Ltd	23.69
s Pty Ltd	8.00
s Pty Ltd	15.21
s Pty Ltd	304.21
s Pty Ltd	82.31
s Pty Ltd	14.03
s Pty Ltd	49.42
s Pty Ltd	31.48
s Pty Ltd	23.88
s Pty Ltd	43.62
s Pty Ltd	11.94
s Pty Ltd	(889.83)
s Pty Ltd	4.53
s Pty Ltd	64.83
s Pty Ltd	213.23
s Pty Ltd	2.83
s Pty Ltd	2,479.90
s Pty Ltd	1,335.33
s Pty Ltd	(1,335.33)
s Pty Ltd	1.22
s Pty Ltd	0.97
s Pty Ltd	5.10
s Pty Ltd	17.30
s Pty Ltd	19.40
s Pty Ltd	12.08
s Pty Ltd	45.89
s Pty Ltd	10.31
s Pty Ltd	279.99
s Pty Ltd	0.35
s Pty Ltd	71.35
s Pty Ltd	14.34
s Pty Ltd	5.74
s Pty Ltd	6.01
s Pty Ltd	113.29
s Pty Ltd	0.68
s Pty Ltd	6.68
s Pty Ltd	1.42
s Pty Ltd	4.72
s Pty Ltd	640.76
s Pty Ltd	57.61
s Pty Ltd	8.76

s Pty Ltd	103.44
s Pty Ltd	1.66
s Pty Ltd	4.89
s Pty Ltd	43.62
s Pty Ltd	4.84
s Pty Ltd	2.13
s Pty Ltd	96.21
s Pty Ltd	11.21
s Pty Ltd	10.44
s Pty Ltd	5.29
s Pty Ltd	177.20
s Pty Ltd	3.80
s Pty Ltd	4.15
s Pty Ltd	4.11
s Pty Ltd	833.16
s Pty Ltd	3.06
s Pty Ltd	116.25
s Pty Ltd	26.61
s Pty Ltd	194.14
s Pty Ltd	1.14
s Pty Ltd	3.64
s Pty Ltd	85.66
s Pty Ltd	3.10
s Pty Ltd	3.35
s Pty Ltd	3.13
s Pty Ltd	9.88
s Pty Ltd	1,185.75
s Pty Ltd	0.31
s Pty Ltd	7.06
s Pty Ltd	7.53
s Pty Ltd	35.65
s Pty Ltd	4.74
s Pty Ltd	4.36
s Pty Ltd	2.10
s Pty Ltd	21.90
s Pty Ltd	1.04
s Pty Ltd	12.54
s Pty Ltd	2.79
s Pty Ltd	210.75
s Pty Ltd	126.42
s Pty Ltd	31.83
s Pty Ltd	6.82
s Pty Ltd	1.72
s Pty Ltd	853.31
s Pty Ltd	69.46
s Pty Ltd	74.85
s Pty Ltd	69.96
s Pty Ltd	1,012.47
s Pty Ltd	12.66
s Pty Ltd	6.68
s Pty Ltd	23.29
s Pty Ltd	5.00
s Pty Ltd	17.56
s Pty Ltd	182.74
s Pty Ltd	20.50
s Pty Ltd	45.10

s Pty Ltd	2.81
s Pty Ltd	2.72
s Pty Ltd	143.64
s Pty Ltd	143.64
s Pty Ltd	1,042.84
s Pty Ltd	14.44
s Pty Ltd	99.96
s Pty Ltd	12.39
s Pty Ltd	5.07
s Pty Ltd	67.54
s Pty Ltd	4.72
s Pty Ltd	310.56
s Pty Ltd	4.57
s Pty Ltd	15.21
s Pty Ltd	62.08
s Pty Ltd	6.06
s Pty Ltd	4.14
s Pty Ltd	16.66
s Pty Ltd	9.67
s Pty Ltd	676.97
s Pty Ltd	547.26
s Pty Ltd	60.30
s Pty Ltd	35.24
s Pty Ltd	346.53
s Pty Ltd	291.58
s Pty Ltd	2,053.35
s Pty Ltd	24.13
s Pty Ltd	725.73
s Pty Ltd	395.79
s Pty Ltd	95.00
s Pty Ltd	158.00
s Pty Ltd	99.75
s Pty Ltd	113.94
s Pty Ltd	681.50
s Pty Ltd	2,030.00
s Pty Ltd	11,600.00
s Pty Ltd	84.99
s Pty Ltd	3.18
s Pty Ltd	874.29
s Pty Ltd	298.89
s Pty Ltd	9.54
s Pty Ltd	12.46
s Pty Ltd	4.93
s Pty Ltd	1.83
s Pty Ltd	14.16
s Pty Ltd	12.10
s Pty Ltd	6.40
s Pty Ltd	7.88
s Pty Ltd	7.98
s Pty Ltd	2.12
s Pty Ltd	5.00
s Pty Ltd	2.76
s Pty Ltd	5.58
s Pty Ltd	6.36
s Pty Ltd	25.10
s Pty Ltd	28.10

s Pty Ltd	19.98
s Pty Ltd	10.56
s Pty Ltd	68.70
s Pty Ltd	68.70
s Pty Ltd	51.86
s Pty Ltd	131.74
s Pty Ltd	23.31
s Pty Ltd	111.56
s Pty Ltd	51.86
s Pty Ltd	18.00
s Pty Ltd	12.00
s Pty Ltd	5.62
s Pty Ltd	404.16
s Pty Ltd	85.00
s Pty Ltd	60.50
s Pty Ltd	(298.89)
s Pty Ltd	76.00
s Pty Ltd	754.47
s Pty Ltd	27.86
s Pty Ltd	328.50
s Pty Ltd	2,271.26
s Pty Ltd	27.86
s Pty Ltd	243.11
	16.36
	30.91
s Pty Ltd	74.50
s Pty Ltd	100.00
s Pty Ltd	55.20
s Pty Ltd	53.20
s Pty Ltd	11.50
s Pty Ltd	20.04
s Pty Ltd	9.88
s Pty Ltd	797.53
s Pty Ltd	300.56
s Pty Ltd	134.14
s Pty Ltd	39.08
s Pty Ltd	36.50
s Pty Ltd	204.58
s Pty Ltd	54.26
s Pty Ltd	455.22
s Pty Ltd	4.42
s Pty Ltd	0.84
s Pty Ltd	13.25
s Pty Ltd	118.24
s Pty Ltd	67.20
s Pty Ltd	13.31
s Pty Ltd	26.58
s Pty Ltd	8.02
s Pty Ltd	25.26
s Pty Ltd	14.13
s Pty Ltd	22.40
s Pty Ltd	13.31
s Pty Ltd	393.90
s Pty Ltd	39.68
s Pty Ltd	29.20
s Pty Ltd	28.40

s Pty Ltd	20.44
s Pty Ltd	70.79
al Services Pty	55.62
al Services Pty	22.50
al Services Pty	5.90
s Pty Ltd	88.04
s Pty Ltd	55.48
s Pty Ltd	88.04
s Pty Ltd	202.42
am.	376.00
s Pty Ltd	115.96
s Pty Ltd	40.11
s Pty Ltd	84.22
s Pty Ltd	121.04
s Pty Ltd	65.66
s Pty Ltd	63.56
s Pty Ltd	78.61
s Pty Ltd	27.11
s Pty Ltd	27.11
s Pty Ltd	62.04
s Pty Ltd	96.08
s Pty Ltd	35.83
s Pty Ltd	50.04
s Pty Ltd	40.11
s Pty Ltd	84.22
s Pty Ltd	60.52
ons Auto	13.64
) Electrical	23.09
al Services Pty	34.76
al Services Pty	23.40
al Services Pty	30.60
s Pty Ltd	308.00
s Pty Ltd	393.90
s Pty Ltd	101.89
s Pty Ltd	4.47
s Pty Ltd	757.33
s Pty Ltd	59.12
s Pty Ltd	44.80
s Pty Ltd	13.31
s Pty Ltd	12.63
s Pty Ltd	770.00
s Pty Ltd	67.76
s Pty Ltd	72.08
s Pty Ltd	23.22
s Pty Ltd	61.30
s Pty Ltd	184.40
s Pty Ltd	282.12
s Pty Ltd	825.99
s Pty Ltd	371.71
s Pty Ltd	1,326.22
s Pty Ltd	168.40
s Pty Ltd	39.33
s Pty Ltd	92.84
s Pty Ltd	4.94
al Services Pty	13.37
al Services Pty	15.48

al Services Pty	5.21
al Services Pty	13.05
al Services Pty	13.95
al Services Pty	6.62
s Pty Ltd	889.97
s Pty Ltd	728.17
s Pty Ltd	199.63
s Pty Ltd	11.34
s Pty Ltd	11.00
s Pty Ltd	4.76
s Pty Ltd	45.20
s Pty Ltd	111.18
s Pty Ltd	71.54
s Pty Ltd	142.76
s Pty Ltd	92.47
s Pty Ltd	7.53
s Pty Ltd	19.52
s Pty Ltd	748.94
s Pty Ltd	32.78
s Pty Ltd	1,216.93
s Pty Ltd	21.66
s Pty Ltd	10.81
s Pty Ltd	32.43
s Pty Ltd	1,612.15
s Pty Ltd	366.12
s Pty Ltd	104.40
s Pty Ltd	(728.17)
s Pty Ltd	228.79
al Services Pty	105.95
on Engineering	980.00
s Pty Ltd	4.94
s Pty Ltd	5.17
s Pty Ltd	95.58
s Pty Ltd	115.96
s Pty Ltd	42.07
s Pty Ltd	149.71
s Pty Ltd	117.36
s Pty Ltd	204.25
s Pty Ltd	315.71
s Pty Ltd	315.71
s Pty Ltd	89.53
s Pty Ltd	17.28
s Pty Ltd	180.42
s Pty Ltd	17.28
s Pty Ltd	90.21
s Pty Ltd	34.56
s Pty Ltd	150.08
s Pty Ltd	316.52
	415.00
s Pty Ltd	41.26
s Pty Ltd	99.10
s Pty Ltd	384.26
s Pty Ltd	41.26
s Pty Ltd	114.14
s Pty Ltd	82.52
s Pty Ltd	106.42

s Pty Ltd	33.81
s Pty Ltd	16.34
s Pty Ltd	115.77
s Pty Ltd	114.14
s Pty Ltd	6.22
s Pty Ltd	4.94
Aust) Pty Limit	3,500.00
s Pty Ltd	92.81
s Pty Ltd	1,220.79
s Pty Ltd	491.81
s Pty Ltd	206.86
s Pty Ltd	181.13
s Pty Ltd	410.93
s Pty Ltd	82.51
s Pty Ltd	209.90
s Pty Ltd	25.44
s Pty Ltd	13.40
s Pty Ltd	37.50
s Pty Ltd	19.93
s Pty Ltd	1.60
s Pty Ltd	11.61
s Pty Ltd	1.53
s Pty Ltd	943.22
s Pty Ltd	289.75
s Pty Ltd	15.36
s Pty Ltd	478.25
s Pty Ltd	309.36
s Pty Ltd	49.47
s Pty Ltd	36.36
s Pty Ltd	95.21
s Pty Ltd	57.88
s Pty Ltd	(289.75)
s Pty Ltd	309.36
s Pty Ltd	95.21
s Pty Ltd	49.47
s Pty Ltd	36.36
s Pty Ltd	326.83
s Pty Ltd	75.18
s Pty Ltd	98.57
s Pty Ltd	4.36
s Pty Ltd	184.38
s Pty Ltd	44.84
s Pty Ltd	141.80
s Pty Ltd	25.96
s Pty Ltd	10.72
s Pty Ltd	2,846.75
s Pty Ltd	20.50
s Pty Ltd	5.44
s Pty Ltd	31.83
s Pty Ltd	9.88
s Pty Ltd	9.69
s Pty Ltd	2.24
s Pty Ltd	146.60
s Pty Ltd	1,292.86
s Pty Ltd	665.98
s Pty Ltd	222.96

s Pty Ltd	14.24
s Pty Ltd	79.64
s Pty Ltd	21.17
s Pty Ltd	12.32
s Pty Ltd	100.86
s Pty Ltd	17.01
s Pty Ltd	216.92
s Pty Ltd	33.80
s Pty Ltd	38.96
s Pty Ltd	(665.98)
s Pty Ltd	248.51
s Pty Ltd	943.22
s Pty Ltd	289.75
s Pty Ltd	15.36
s Pty Ltd	8.99
s Pty Ltd	8.74
s Pty Ltd	10.76
s Pty Ltd	26.14
s Pty Ltd	106.59
Centre	62.69
s Pty Ltd	(289.75)
s Pty Ltd	427.38
s Pty Ltd	242.97
s Pty Ltd	94.56
s Pty Ltd	3.56
s Pty Ltd	4.16
s Pty Ltd	13.80
s Pty Ltd	43.80
s Pty Ltd	53.70
s Pty Ltd	56.00
s Pty Ltd	789.50
s Pty Ltd	299.62
s Pty Ltd	91.68
s Pty Ltd	34.99
s Pty Ltd	12.14
s Pty Ltd	6.92
s Pty Ltd	39.38
s Pty Ltd	61.16
s Pty Ltd	2.28
s Pty Ltd	3.39
s Pty Ltd	60.50
s Pty Ltd	22.98
s Pty Ltd	67.50
s Pty Ltd	36.00
s Pty Ltd	25.34
s Pty Ltd	22.92
s Pty Ltd	23.43
s Pty Ltd	72.71
s Pty Ltd	90.78
s Pty Ltd	278.61
s Pty Ltd	16.58
s Pty Ltd	11.42
s Pty Ltd	4.88
s Pty Ltd	20.36
s Pty Ltd	98.57
s Pty Ltd	4.36

s Pty Ltd	12.84
s Pty Ltd	31.78
s Pty Ltd	141.60
s Pty Ltd	72.00
s Pty Ltd	49.28
s Pty Ltd	34.20
s Pty Ltd	93.51
s Pty Ltd	153.13
s Pty Ltd	75.46
s Pty Ltd	323.04
s Pty Ltd	185.79
s Pty Ltd	372.07
s Pty Ltd	322.25
s Pty Ltd	16.21
s Pty Ltd	2.70
s Pty Ltd	1.72
s Pty Ltd	22.44
s Pty Ltd	22.92
s Pty Ltd	4.40
s Pty Ltd	17.24
s Pty Ltd	9.88
s Pty Ltd	75.18
s Pty Ltd	3.26
s Pty Ltd	1,197.21
s Pty Ltd	1,952.89
s Pty Ltd	15.18
s Pty Ltd	559.38
s Pty Ltd	72.33
s Pty Ltd	87.32
s Pty Ltd	63.72
s Pty Ltd	284.64
s Pty Ltd	4.94
s Pty Ltd	450.76
s Pty Ltd	7.68
s Pty Ltd	147.76
s Pty Ltd	7.28
s Pty Ltd	1,622.69
on Engineering	60.00
s Pty Ltd	510.52
s Pty Ltd	104.04
s Pty Ltd	18.90
s Pty Ltd	2.48
s Pty Ltd	22.30
s Pty Ltd	63.30
s Pty Ltd	5.85
s Pty Ltd	59.12
s Pty Ltd	67.50
s Pty Ltd	38.33
s Pty Ltd	19.60
s Pty Ltd	6.90
s Pty Ltd	14.28
s Pty Ltd	10.68
s Pty Ltd	7.20
s Pty Ltd	3.20
s Pty Ltd	5.10
s Pty Ltd	10.45

s Pty Ltd	10.04
s Pty Ltd	9.45
s Pty Ltd	35.51
s Pty Ltd	80.14
s Pty Ltd	9.92
s Pty Ltd	195.82
on Engineering	480.00
s Pty Ltd	16.64
s Pty Ltd	16.60
s Pty Ltd	1.47
s Pty Ltd	13.48
s Pty Ltd	19.36
s Pty Ltd	66.22
s Pty Ltd	20.40
s Pty Ltd	8.96
s Pty Ltd	29.80
s Pty Ltd	12.20
s Pty Ltd	10.80
s Pty Ltd	17.80
s Pty Ltd	20.00
s Pty Ltd	9.80
s Pty Ltd	15.20
s Pty Ltd	10.29
s Pty Ltd	6.74
s Pty Ltd	49.92
s Pty Ltd	5.24
s Pty Ltd	38.40
s Pty Ltd	68.40
s Pty Ltd	45.51
s Pty Ltd	(147.76)
s Pty Ltd	(7.28)
s Pty Ltd	(1,622.69)
s Pty Ltd	(3.56)
s Pty Ltd	(4.16)
s Pty Ltd	(13.80)
s Pty Ltd	(43.80)
s Pty Ltd	(53.70)
s Pty Ltd	(56.00)
s Pty Ltd	(789.50)
s Pty Ltd	(299.62)
s Pty Ltd	(91.68)
s Pty Ltd	(34.99)
s Pty Ltd	(12.14)
s Pty Ltd	(6.92)
s Pty Ltd	(39.38)
s Pty Ltd	(61.16)
s Pty Ltd	(2.28)
s Pty Ltd	(3.39)
s Pty Ltd	(60.50)
s Pty Ltd	(22.98)
s Pty Ltd	(67.50)
s Pty Ltd	(36.00)
s Pty Ltd	(25.34)
s Pty Ltd	(22.92)
s Pty Ltd	(23.43)
s Pty Ltd	(72.71)

s Pty Ltd	(90.78)
s Pty Ltd	(278.61)
s Pty Ltd	(16.58)
s Pty Ltd	(11.42)
s Pty Ltd	(4.88)
s Pty Ltd	(20.36)
s Pty Ltd	(98.57)
s Pty Ltd	(4.36)
s Pty Ltd	(12.84)
s Pty Ltd	(31.78)
s Pty Ltd	(141.60)
s Pty Ltd	(72.00)
s Pty Ltd	(49.28)
s Pty Ltd	(34.20)
s Pty Ltd	(93.51)
s Pty Ltd	(153.13)
s Pty Ltd	(75.46)
s Pty Ltd	(323.04)
s Pty Ltd	(185.79)
s Pty Ltd	(372.07)
s Pty Ltd	(322.25)
s Pty Ltd	(16.21)
s Pty Ltd	(2.70)
s Pty Ltd	(1.72)
s Pty Ltd	(22.44)
s Pty Ltd	(22.92)
s Pty Ltd	(4.40)
s Pty Ltd	(17.24)
s Pty Ltd	(9.88)
s Pty Ltd	(75.18)
s Pty Ltd	(3.26)
s Pty Ltd	(1,197.21)
s Pty Ltd	(1,952.89)
s Pty Ltd	(15.18)
s Pty Ltd	(559.38)
s Pty Ltd	(72.33)
s Pty Ltd	(87.32)
s Pty Ltd	(63.72)
s Pty Ltd	(284.64)
s Pty Ltd	(4.94)
s Pty Ltd	(450.76)
s Pty Ltd	(7.68)
s Pty Ltd	0.00
s Pty Ltd	3.26
s Pty Ltd	31.78
s Pty Ltd	4.36
s Pty Ltd	98.57
s Pty Ltd	49.28
s Pty Ltd	53.70
s Pty Ltd	56.00
s Pty Ltd	39.38
s Pty Ltd	61.16
s Pty Ltd	87.32
s Pty Ltd	12.84
s Pty Ltd	34.20
s Pty Ltd	43.80

s Pty Ltd	34.99
s Pty Ltd	75.18
s Pty Ltd	2.28
s Pty Ltd	1.72
s Pty Ltd	147.76
s Pty Ltd	12.14
s Pty Ltd	16.21
s Pty Ltd	141.60
s Pty Ltd	14.82
s Pty Ltd	75.46
s Pty Ltd	11.42
s Pty Ltd	16.58
s Pty Ltd	4.88
s Pty Ltd	15.18
s Pty Ltd	3.56
s Pty Ltd	4.16
s Pty Ltd	7.28
s Pty Ltd	6.92
s Pty Ltd	91.68
s Pty Ltd	20.36
s Pty Ltd	559.38
s Pty Ltd	25.34
s Pty Ltd	1,622.69
s Pty Ltd	72.71
s Pty Ltd	90.78
s Pty Ltd	2.70
s Pty Ltd	13.80
s Pty Ltd	3.39
s Pty Ltd	22.98
s Pty Ltd	45.84
s Pty Ltd	22.44
s Pty Ltd	284.64
s Pty Ltd	72.00
s Pty Ltd	1,197.21
s Pty Ltd	1,952.89
s Pty Ltd	185.79
s Pty Ltd	63.72
s Pty Ltd	72.33
s Pty Ltd	278.61
s Pty Ltd	153.13
s Pty Ltd	93.51
s Pty Ltd	789.50
s Pty Ltd	67.50
s Pty Ltd	60.50
s Pty Ltd	322.25
s Pty Ltd	372.07
s Pty Ltd	323.04
s Pty Ltd	23.43
s Pty Ltd	299.62
s Pty Ltd	4.40
s Pty Ltd	17.24
s Pty Ltd	36.00
s Pty Ltd	450.76
s Pty Ltd	3,840.00
s Pty Ltd	605.29
s Pty Ltd	43,666.77

s Pty Ltd	16,981.53
s Pty Ltd	(16,981.53)
s Pty Ltd	660.00
s Pty Ltd	192.00
al Services Pty	17.50
al Services Pty	10.80
al Services Pty	46.54
al Services Pty	19.80
al Services Pty	43.40
al Services Pty	68.50
al Services Pty	43.77
al Services Pty	16.20
al Services Pty	25.50
al Services Pty	46.70
al Services Pty	95.34
airs	1,800.00
al Services Pty	40.40
al Services Pty	71.80
al Services Pty	46.35
al Services Pty	26.80
s Pty Ltd	23.94
s Pty Ltd	422.64
s Pty Ltd	455.84
s Pty Ltd	455.84
s Pty Ltd	195.08
s Pty Ltd	163.33
s Pty Ltd	199.46
s Pty Ltd	163.33
s Pty Ltd	173.49
s Pty Ltd	45.70
g Mildura Pty L	90.30
s Pty Ltd	196.53
s Pty Ltd	57.83
s Pty Ltd	19.38
s Pty Ltd	196.53
al Services Pty	16.20
al Services Pty	66.00
al Services Pty	43.20
al Services Pty	56.80
al Services Pty	150.60
al Services Pty	35.90
al Services Pty	74.00
al Services Pty	74.00
al Services Pty	121.00
al Services Pty	25.00
al Services Pty	28.20
al Services Pty	117.30
al Services Pty	44.80
al Services Pty	44.70
al Services Pty	34.50
al Services Pty	393.60
Centre	213.10
s Pty Ltd	156.66
s Pty Ltd	55.16
s Pty Ltd	558.28
g Mildura Pty L	138.70

s Pty Ltd	34.53
s Pty Ltd	81.93
s Pty Ltd	208.47
s Pty Ltd	25.26
s Pty Ltd	5.52
s Pty Ltd	118.56
s Pty Ltd	41.64
s Pty Ltd	15.52
s Pty Ltd	561.18
	8,635.00
	4,000.00
s Pty Ltd	488.35
s Pty Ltd	205.40
s Pty Ltd	179.88
s Pty Ltd	408.04
s Pty Ltd	12.21
s Pty Ltd	4.85
s Pty Ltd	20.66
s Pty Ltd	2.10
s Pty Ltd	18.48
s Pty Ltd	38.28
s Pty Ltd	20.00
s Pty Ltd	1,208.80
s Pty Ltd	622.70
s Pty Ltd	413.20
s Pty Ltd	216.80
s Pty Ltd	12.76
s Pty Ltd	4.20
s Pty Ltd	(622.70)
s Pty Ltd	253.80
s Pty Ltd	119.84
	(4,000.00)
s Pty Ltd	1,208.80
s Pty Ltd	622.70
al Services Pty	77.70
al Services Pty	127.00
al Services Pty	98.40
al Services Pty	380.00
s Pty Ltd	173.71
s Pty Ltd	175.72
s Pty Ltd	287.80
s Pty Ltd	173.71
	525.00
s Pty Ltd	17.68
s Pty Ltd	222.03
s Pty Ltd	217.36
s Pty Ltd	247.13
	200.00
	232.00
	110.00
ctors Pty Ltd	1,491.84
s Pty Ltd	288.70
s Pty Ltd	46.24
s Pty Ltd	57.80
s Pty Ltd	34.68
s Pty Ltd	57.80

s Pty Ltd	453.85
s Pty Ltd	278.02
s Pty Ltd	134.98
s Pty Ltd	121.04
	810.00
	720.00
s Pty Ltd	197.08
s Pty Ltd	81.56
s Pty Ltd	237.92
s Pty Ltd	141.34
	560.00
	80.00
s Pty Ltd	138.88
s Pty Ltd	84.81
s Pty Ltd	337.40
s Pty Ltd	290.76
s Pty Ltd	125.15
s Pty Ltd	76.72
s Pty Ltd	300.13
s Pty Ltd	76.72
s Pty Ltd	279.63
s Pty Ltd	343.26
s Pty Ltd	106.36
s Pty Ltd	73.08
al Services Pty	67.80
al Services Pty	76.80
al Services Pty	9.90
al Services Pty	18.05
al Services Pty	12.20
al Services Pty	72.50
al Services Pty	31.80
al Services Pty	9.90
al Services Pty	26.70
al Services Pty	23.00
al Services Pty	12.00
al Services Pty	17.50
al Services Pty	8.45
s Pty Ltd	69.06
s Pty Ltd	314.08
s Pty Ltd	106.36
s Pty Ltd	119.14
s Pty Ltd	40.60
on Engineering	680.00
s Pty Ltd	8.88
s Pty Ltd	24.60
s Pty Ltd	9.68
s Pty Ltd	11.58
s Pty Ltd	4.47
s Pty Ltd	24.36
s Pty Ltd	52.70
s Pty Ltd	5.79
s Pty Ltd	201.76
s Pty Ltd	149.30
s Pty Ltd	79.07
s Pty Ltd	211.34
s Pty Ltd	132.32

s Pty Ltd	212.72
s Pty Ltd	112.80
on Engineering	1,300.00
on Engineering	545.00
s Pty Ltd	502.53
s Pty Ltd	211.35
s Pty Ltd	146.11
s Pty Ltd	419.89
s Pty Ltd	469.98
s Pty Ltd	27.36
s Pty Ltd	(622.70)
	165.00
	6.00
	330.00
	24.00
s Pty Ltd	1,706.97
s Pty Ltd	82.14
s Pty Ltd	12.75
s Pty Ltd	1,981.90
s Pty Ltd	13.50
s Pty Ltd	176.13
s Pty Ltd	1,986.82
s Pty Ltd	133.10
s Pty Ltd	650.61
s Pty Ltd	961.03
s Pty Ltd	27.08
s Pty Ltd	83.81
s Pty Ltd	112.97
s Pty Ltd	16.92
s Pty Ltd	40.88
s Pty Ltd	12.10
s Pty Ltd	32.00
s Pty Ltd	10.97
s Pty Ltd	1,483.11
s Pty Ltd	72.29
s Pty Ltd	213.35
s Pty Ltd	42.53
s Pty Ltd	784.75
s Pty Ltd	37.39
s Pty Ltd	421.50
s Pty Ltd	24.90
s Pty Ltd	398.11
s Pty Ltd	328.88
s Pty Ltd	7.79
s Pty Ltd	643.14
s Pty Ltd	20.28
s Pty Ltd	105.68
s Pty Ltd	13.36
s Pty Ltd	48.86
s Pty Ltd	0.98
s Pty Ltd	57.39
s Pty Ltd	0.72
s Pty Ltd	106.80
s Pty Ltd	58.50
s Pty Ltd	2.50
s Pty Ltd	27.76

s Pty Ltd	39.84
s Pty Ltd	3.60
s Pty Ltd	228.02
s Pty Ltd	27.35
s Pty Ltd	12.06
s Pty Ltd	116.88
s Pty Ltd	73.29
s Pty Ltd	175.60
s Pty Ltd	71.05
s Pty Ltd	22.79
s Pty Ltd	13.25
s Pty Ltd	1.46
s Pty Ltd	2.64
s Pty Ltd	7.81
s Pty Ltd	6.75
s Pty Ltd	72.90
s Pty Ltd	3.28
s Pty Ltd	18.56
s Pty Ltd	16.80
s Pty Ltd	5.14
s Pty Ltd	0.86
s Pty Ltd	14.88
s Pty Ltd	2.81
s Pty Ltd	7.99
s Pty Ltd	0.84
s Pty Ltd	1.35
s Pty Ltd	6.00
s Pty Ltd	1.40
s Pty Ltd	0.44
s Pty Ltd	0.88
s Pty Ltd	3.80
s Pty Ltd	3.98
s Pty Ltd	3.28
s Pty Ltd	316.67
s Pty Ltd	269.28
s Pty Ltd	85.44
s Pty Ltd	82.15
s Pty Ltd	1,512.20
s Pty Ltd	67.67
s Pty Ltd	421.08
s Pty Ltd	53.90
s Pty Ltd	79.76
s Pty Ltd	13.96
s Pty Ltd	139.36
s Pty Ltd	382.59
s Pty Ltd	127.90
s Pty Ltd	7.79
s Pty Ltd	134.60
s Pty Ltd	247.53
s Pty Ltd	148.42
s Pty Ltd	56.50
s Pty Ltd	19.56
s Pty Ltd	87.90
s Pty Ltd	17.50
s Pty Ltd	3.93
s Pty Ltd	3.76

s Pty Ltd	203.18
s Pty Ltd	363.04
s Pty Ltd	8.74
s Pty Ltd	3.16
s Pty Ltd	78.36
s Pty Ltd	201.28
s Pty Ltd	8.82
s Pty Ltd	1.96
s Pty Ltd	4.86
s Pty Ltd	5.00
s Pty Ltd	28.10
s Pty Ltd	25.74
s Pty Ltd	118.16
s Pty Ltd	872.36
s Pty Ltd	11.60
s Pty Ltd	2,357.36
s Pty Ltd	1,269.38
s Pty Ltd	11.78
s Pty Ltd	56.72
s Pty Ltd	405.33
s Pty Ltd	81.60
s Pty Ltd	1,022.68
s Pty Ltd	15.00
s Pty Ltd	15.64
s Pty Ltd	39.07
s Pty Ltd	594.28
s Pty Ltd	207.44
s Pty Ltd	673.71
s Pty Ltd	109.58
s Pty Ltd	384.67
s Pty Ltd	9.64
s Pty Ltd	130.17
s Pty Ltd	290.11
s Pty Ltd	96.08
s Pty Ltd	78.36
s Pty Ltd	96.28
s Pty Ltd	10.02
s Pty Ltd	8.81
s Pty Ltd	0.96
s Pty Ltd	23.43
s Pty Ltd	405.33
s Pty Ltd	1,710.95
s Pty Ltd	8.39
s Pty Ltd	266.19
s Pty Ltd	390.79
s Pty Ltd	25.64
s Pty Ltd	51.28
s Pty Ltd	34.62
s Pty Ltd	52.97
s Pty Ltd	7.06
s Pty Ltd	13.18
s Pty Ltd	37.24
s Pty Ltd	1.02
s Pty Ltd	2.66
s Pty Ltd	34.62
s Pty Ltd	4.72

s Pty Ltd	40.32
s Pty Ltd	14.38
s Pty Ltd	24.85
s Pty Ltd	4.26
s Pty Ltd	5.53
s Pty Ltd	1.76
s Pty Ltd	1.53
s Pty Ltd	121.52
s Pty Ltd	113.44
s Pty Ltd	4.15
s Pty Ltd	7.76
s Pty Ltd	16.14
s Pty Ltd	7.57
s Pty Ltd	16.80
s Pty Ltd	17.00
s Pty Ltd	2.70
s Pty Ltd	2.81
s Pty Ltd	3.67
s Pty Ltd	4.65
s Pty Ltd	2,558.85
s Pty Ltd	1,045.18
s Pty Ltd	20.19
s Pty Ltd	8.22
s Pty Ltd	2.36
s Pty Ltd	1.76
s Pty Ltd	5.06
s Pty Ltd	7.57
s Pty Ltd	16.80
s Pty Ltd	34.50
s Pty Ltd	6.50
s Pty Ltd	8.50
s Pty Ltd	5.67
s Pty Ltd	1.38
s Pty Ltd	1.90
s Pty Ltd	15.26
ent	960.00
s Pty Ltd	20.32
s Pty Ltd	18.60
s Pty Ltd	19.36
s Pty Ltd	6.38
s Pty Ltd	2.64
s Pty Ltd	7.68
s Pty Ltd	7.32
s Pty Ltd	34.04
s Pty Ltd	1.90
s Pty Ltd	4.65
s Pty Ltd	15.28
s Pty Ltd	71.79
s Pty Ltd	4.65
s Pty Ltd	99.28
s Pty Ltd	63.60
s Pty Ltd	18.60
s Pty Ltd	12.76
s Pty Ltd	252.48
s Pty Ltd	315.20
s Pty Ltd	2.44

s Pty Ltd	1,243.55
s Pty Ltd	27.68
s Pty Ltd	34.80
s Pty Ltd	5.80
s Pty Ltd	13.54
s Pty Ltd	15.79
s Pty Ltd	22.58
s Pty Ltd	9.36
s Pty Ltd	5.41
s Pty Ltd	2.41
s Pty Ltd	302.23
s Pty Ltd	19.56
in Elec & Air	280.70
& Company Pt	1,123.00
& Company Pt	240.00
& Company Pt	1,000.00
& Company Pt	340.00
& Company Pt	340.00
& Company Pt	450.00
s Pty Ltd	633.34
s Pty Ltd	15,000.00
s Pty Ltd	316.67
s Pty Ltd	(1,269.38)
s Pty Ltd	(1,045.18)
s Pty Ltd	21.98
s Pty Ltd	27.02
s Pty Ltd	31.92
s Pty Ltd	0.33
s Pty Ltd	40.32
s Pty Ltd	1,622.49
s Pty Ltd	61.36
s Pty Ltd	40.96
s Pty Ltd	60.69
s Pty Ltd	356.21
s Pty Ltd	374.12
s Pty Ltd	11.34
s Pty Ltd	8.43
s Pty Ltd	960.00
s Pty Ltd	660.44
s Pty Ltd	4.15
s Pty Ltd	120.56
s Pty Ltd	159.00
s Pty Ltd	4.15
s Pty Ltd	28.62
s Pty Ltd	63.43
s Pty Ltd	37.30
s Pty Ltd	91.54
s Pty Ltd	85.13
s Pty Ltd	0.33
s Pty Ltd	13.44
s Pty Ltd	5.84
s Pty Ltd	59.52
s Pty Ltd	13.01
s Pty Ltd	91.54
s Pty Ltd	89.60
s Pty Ltd	1,152.45

s Pty Ltd	340.52
s Pty Ltd	274.62
s Pty Ltd	729.58
s Pty Ltd	212.47
s Pty Ltd	797.76
s Pty Ltd	84.08
s Pty Ltd	200.33
s Pty Ltd	180.23
s Pty Ltd	132.52
s Pty Ltd	166.44
s Pty Ltd	231.84
s Pty Ltd	284.28
s Pty Ltd	284.57
	520.00
	100.00
	115.00
	175.00
	85.00
s Pty Ltd	63.65
s Pty Ltd	63.65
ngineering Pty	220.00
s Pty Ltd	8.72
s Pty Ltd	2.46
s Pty Ltd	340.52
s Pty Ltd	212.47
s Pty Ltd	670.26
s Pty Ltd	91.54
s Pty Ltd	91.54
ngineering Pty	220.00
s Pty Ltd	85.10
s Pty Ltd	15.36
s Pty Ltd	7.04
s Pty Ltd	167.69
s Pty Ltd	66.58
s Pty Ltd	7.32
s Pty Ltd	43.28
s Pty Ltd	31.94
s Pty Ltd	35.78
s Pty Ltd	8.61
s Pty Ltd	7.88
s Pty Ltd	46.96
s Pty Ltd	14.75
s Pty Ltd	1.72
on Engineering	422.50
s Pty Ltd	15.42
s Pty Ltd	4.80
s Pty Ltd	66.60
s Pty Ltd	91.20
	965.00
hine Shop	13.64
hine Shop	200.00
s Pty Ltd	18.64
s Pty Ltd	23.35
s Pty Ltd	2,955.47
s Pty Ltd	1,207.19
s Pty Ltd	186.36

s Pty Ltd	(1,207.19)
s Pty Ltd	5.14
& Company Pt	35.00
& Company Pt	950.00
& Company Pt	1,650.00
s Pty Ltd	0.70
s Pty Ltd	0.16
s Pty Ltd	6.58
s Pty Ltd	161.85
s Pty Ltd	179.36
s Pty Ltd	4.32
s Pty Ltd	47.14
s Pty Ltd	49.85
s Pty Ltd	20.16
s Pty Ltd	135.70
s Pty Ltd	76.70
s Pty Ltd	10.92
s Pty Ltd	5.10
s Pty Ltd	26.16
s Pty Ltd	41.76
s Pty Ltd	125.19
s Pty Ltd	5.10
s Pty Ltd	248.13
s Pty Ltd	20.40
s Pty Ltd	80.48
s Pty Ltd	96.25
s Pty Ltd	20.16
s Pty Ltd	20.12
s Pty Ltd	41.25
s Pty Ltd	32.94
s Pty Ltd	4.62
s Pty Ltd	20.48
s Pty Ltd	50.93
s Pty Ltd	2.76
s Pty Ltd	61.02
s Pty Ltd	27.04
s Pty Ltd	28.02
s Pty Ltd	46.02
s Pty Ltd	151.52
s Pty Ltd	210.48
s Pty Ltd	196.56
s Pty Ltd	277.83
s Pty Ltd	14.60
s Pty Ltd	4.56
s Pty Ltd	0.38
s Pty Ltd	15.48
s Pty Ltd	102.48
s Pty Ltd	79.36
s Pty Ltd	12.90
s Pty Ltd	16.08
s Pty Ltd	16.88
s Pty Ltd	14.44
s Pty Ltd	17.56
s Pty Ltd	15.03
s Pty Ltd	77.70
s Pty Ltd	142.53

s Pty Ltd	52.64
s Pty Ltd	7.00
s Pty Ltd	61.26
s Pty Ltd	10.28
s Pty Ltd	0.38
s Pty Ltd	12.80
s Pty Ltd	12.90
s Pty Ltd	49.97
s Pty Ltd	36.90
s Pty Ltd	41.33
s Pty Ltd	9.10
s Pty Ltd	54.24
s Pty Ltd	1.99
s Pty Ltd	8.51
s Pty Ltd	3,496.08
s Pty Ltd	290.72
s Pty Ltd	302.35
s Pty Ltd	798.62
s Pty Ltd	73.78
s Pty Ltd	121.04
s Pty Ltd	780.62
s Pty Ltd	116.64
s Pty Ltd	288.60
s Pty Ltd	1,624.56
s Pty Ltd	89.69
s Pty Ltd	172.84
s Pty Ltd	76.89
s Pty Ltd	9.93
s Pty Ltd	17.04
s Pty Ltd	77.70
s Pty Ltd	248.30
s Pty Ltd	213.70
s Pty Ltd	1,872.64
s Pty Ltd	3,440.72
s Pty Ltd	514.14
s Pty Ltd	730.36
s Pty Ltd	288.60
s Pty Ltd	172.84
s Pty Ltd	1,624.56
s Pty Ltd	214.12
s Pty Ltd	73.26
s Pty Ltd	2,349.30
s Pty Ltd	842.66
s Pty Ltd	490.80
s Pty Ltd	921.44
s Pty Ltd	97.11
s Pty Ltd	231.38
s Pty Ltd	612.24
s Pty Ltd	232.72
s Pty Ltd	267.78
s Pty Ltd	328.33
s Pty Ltd	328.67
s Pty Ltd	269.07
s Pty Ltd	147.06
s Pty Ltd	90.14
s Pty Ltd	370.50

s Pty Ltd	139.42
s Pty Ltd	203.86
s Pty Ltd	119.78
s Pty Ltd	97.11
s Pty Ltd	1,548.28
s Pty Ltd	57.38
s Pty Ltd	19.73
s Pty Ltd	525.38
	4,126.00
s Pty Ltd	187.99
s Pty Ltd	13,732.99
al Services Pty	18.20
al Services Pty	102.00
al Services Pty	186.80
al Services Pty	242.05
al Services Pty	64.80
rtable Line Bor	6,463.64
s Pty Ltd	66.25
s Pty Ltd	1,188.12
s Pty Ltd	763.88
s Pty Ltd	550.22
s Pty Ltd	408.07
s Pty Ltd	56.37
s Pty Ltd	515.15
s Pty Ltd	10.49
s Pty Ltd	18.36
s Pty Ltd	78.78
s Pty Ltd	0.58
s Pty Ltd	48.42
s Pty Ltd	317.88
s Pty Ltd	6.81
s Pty Ltd	228.92
s Pty Ltd	8.54
s Pty Ltd	529.69
s Pty Ltd	205.38
s Pty Ltd	53.84
	680.00
s Pty Ltd	282.94
s Pty Ltd	396.93
s Pty Ltd	13.36
s Pty Ltd	196.39
s Pty Ltd	394.52
s Pty Ltd	120.24
s Pty Ltd	123.18
s Pty Ltd	92.74
s Pty Ltd	788.82
s Pty Ltd	56.20
Electronics P//	120.00
Electronics P//	60.00
Electronics P//	100.00
s Pty Ltd	(7,307.39)
s Pty Ltd	654.45
s Pty Ltd	118.78
s Pty Ltd	347.01
s Pty Ltd	1,265.95
s Pty Ltd	269.48

s Pty Ltd	261.04
s Pty Ltd	163.44
s Pty Ltd	985.36
s Pty Ltd	230.26
s Pty Ltd	492.54
s Pty Ltd	289.97
s Pty Ltd	1,629.47
s Pty Ltd	250.16
s Pty Ltd	1,207.42
s Pty Ltd	2,020.08
s Pty Ltd	4,319.28
s Pty Ltd	606.85
s Pty Ltd	1,586.37
s Pty Ltd	13,749.37
parens Pty Ltd	560.00
s Pty Ltd	80.00
s Pty Ltd	2,956.03
s Pty Ltd	2,753.39
s Pty Ltd	652.31
s Pty Ltd	4,053.90
s Pty Ltd	8,583.78
s Pty Ltd	6,162.00
al Services Pty	3,111.20
s Pty Ltd	36.44
s Pty Ltd	64.00
s Pty Ltd	461.69
s Pty Ltd	19.16
s Pty Ltd	5,033.31
s Pty Ltd	2,055.89
s Pty Ltd	55.23
ngineering Pty	952.00
s Pty Ltd	85.48
s Pty Ltd	3,548.82
s Pty Ltd	(2,055.89)
s Pty Ltd	63.77
s Pty Ltd	201.31
s Pty Ltd	653.04
s Pty Ltd	809.15
s Pty Ltd	1,432.56
s Pty Ltd	1,154.06
s Pty Ltd	753.47
s Pty Ltd	1,170.48
s Pty Ltd	3,642.03
s Pty Ltd	58.94
s Pty Ltd	29.79
s Pty Ltd	9.85
s Pty Ltd	293.91
s Pty Ltd	4.15
s Pty Ltd	(1,063.86)
s Pty Ltd	57.42
s Pty Ltd	56.87
al Services Pty	17.40
s Pty Ltd	(990.96)
s Pty Ltd	27.18
s Pty Ltd	225.00
s Pty Ltd	346.42

s Pty Ltd	17.16
s Pty Ltd	840.47
al Services Pty	891.80
s Pty Ltd	839.70
s Pty Ltd	292.11
al Services Pty	573.60
al Services Pty	58.94
al Services Pty	61.46
al Services Pty	61.46
al Services Pty	61.46
al Services Pty	61.46
al Services Pty	61.46
al Services Pty	61.46
al Services Pty	61.46
al Services Pty	61.46
al Services Pty	71.06
s Pty Ltd	1,879.56
s Pty Ltd	506.94
al Services Pty	12.96
al Services Pty	47.52
al Services Pty	90.36
al Services Pty	117.00
al Services Pty	19.44
al Services Pty	61.20
al Services Pty	106.08
al Services Pty	81.84
al Services Pty	44.52
al Services Pty	580.80
Contracting Co	8,000.00
s Pty Ltd	140.73
s Pty Ltd	84.69
s Pty Ltd	360.97
s Pty Ltd	2,310.17
s Pty Ltd	55.64
s Pty Ltd	55.64
s Pty Ltd	62.32
s Pty Ltd	55.12
s Pty Ltd	319.56
s Pty Ltd	699.79
s Pty Ltd	598.83
s Pty Ltd	4.23
s Pty Ltd	55.12
s Pty Ltd	196.35
s Pty Ltd	12.38
s Pty Ltd	25.98
s Pty Ltd	354.81
s Pty Ltd	641.48
s Pty Ltd	71.62
s Pty Ltd	94.32
s Pty Ltd	531.77
s Pty Ltd	652.22
al Services Pty	31.20
al Services Pty	21.60
al Services Pty	41.52
al Services Pty	16.92
s Pty Ltd	9.16
s Pty Ltd	34.05

s Pty Ltd	661.75
s Pty Ltd	22.14
s Pty Ltd	116.82
s Pty Ltd	17.86
s Pty Ltd	4,046.02
s Pty Ltd	204.69
s Pty Ltd	107.04
s Pty Ltd	438.74
s Pty Ltd	6.52
s Pty Ltd	91.58
al Services Pty	1,011.12
s Pty Ltd	2,310.17
s Pty Ltd	84.69
s Pty Ltd	33.07
s Pty Ltd	283.38
s Pty Ltd	1,350.11
s Pty Ltd	248.64
s Pty Ltd	822.51
s Pty Ltd	328.31
is and Fastner:	28.41
is and Fastner:	3.18
	350.00
s Pty Ltd	307.59
s Pty Ltd	29.64
s Pty Ltd	377.08
s Pty Ltd	1,063.98
s Pty Ltd	2,297.51
s Pty Ltd	792.05
s Pty Ltd	117.77
s Pty Ltd	822.51
s Pty Ltd	700.00
ig Pty Ltd	1,596.60
al Services Pty	58.97
al Services Pty	74.52
al Services Pty	55.08
al Services Pty	76.46
al Services Pty	51.84
al Services Pty	68.04
al Services Pty	22.25
al Services Pty	38.23
al Services Pty	232.20
al Services Pty	217.08
al Services Pty	67.50
al Services Pty	3,985.74
s Pty Ltd	713.90
s Pty Ltd	140.56
s Pty Ltd	136.05
al Services Pty	184.80
al Services Pty	304.80
al Services Pty	310.80
al Services Pty	277.20
al Services Pty	228.00
al Services Pty	118.08
al Services Pty	304.80
al Services Pty	228.00
al Services Pty	92.40

al Services Pty	310.80
al Services Pty	277.20
s Pty Ltd	809.88
s Pty Ltd	339.53
s Pty Ltd	434.83
s Pty Ltd	512.17
s Pty Ltd	110.08
s Pty Ltd	179.40
s Pty Ltd	22.28
s Pty Ltd	527.92
s Pty Ltd	280.70
s Pty Ltd	22.28
s Pty Ltd	197.98
s Pty Ltd	243.60
s Pty Ltd	723.83
s Pty Ltd	41.67
s Pty Ltd	328.40
s Pty Ltd	247.54
s Pty Ltd	125.01
ig Pty Ltd	1,378.79
s Pty Ltd	327.10
s Pty Ltd	41.71
s Pty Ltd	9.17
s Pty Ltd	202.90
s Pty Ltd	470.70
s Pty Ltd	351.60
s Pty Ltd	250.02
s Pty Ltd	235.86
al Services Pty	44.52
al Services Pty	67.32
al Services Pty	88.80
al Services Pty	871.20
s Pty Ltd	961.02
s Pty Ltd	1,230.24
s Pty Ltd	341.49
s Pty Ltd	1,622.66
s Pty Ltd	106.41
s Pty Ltd	505.69
s Pty Ltd	752.30
s Pty Ltd	497.56
s Pty Ltd	115.16
& Company Pt	1,009.00
s Pty Ltd	1,142.64
s Pty Ltd	116.68
s Pty Ltd	127.15
s Pty Ltd	218.29
	<u>604,029.63</u>
	<u>604,029.63</u>
	604,029.63

thmover Pty Lt	26,368.00
	6,643.00
arthmover Tyr	22,268.88
arthmover Tyr	11,134.15

arthmover Typ	11,134.15
	<u>77,548.18</u>
	<u>77,548.18</u>
	77,548.18

Date	Work Description
24/01/19	SC09 - replace hyd hose
11/08/20	SC09 - brake repairs
23/09/20	SC09 - service & start front engine tune up
23/09/20	SC09 - service
24/09/20	SC09 - front engine tune up & service
24/09/20	SC09 - service
25/09/20	SC09 - seat wiring & pressure sensor
28/09/20	SC09 - remove seat & harness & test batteries
28/09/20	SC09 - repairs
29/09/20	SC09 - jump start machine
13/10/20	SC09 - c/o routers
13/10/20	SC09 - c/o cutting edges
21/10/20	SC09 - repace load counter
30/10/20	SC09 - rotate GET
30/10/20	SC09 - rotate edges & flashing light holder
04/11/20	SC09 - flat batteries
10/11/20	SC09 - mine radio & reversing camera elect fault
13/11/20	SC09 - wash, service & defects
13/11/20	SC09 - service
03/12/20	SC09 - c/o trans hose
08/12/20	SC09 - fan belt repairs
09/12/20	SC09 - rear engine belts & engine bay door
15/12/20	SC09 - repairs
15/12/20	SC09 - lift cylinder hoses
15/12/20	SC09 - blown hoses
14/01/21	SC09 - repair wiring & hose for grease fault
27/01/21	SC09 - service
27/01/21	SC09 - service & defects
28/01/21	SC09 - service
28/01/21	SC09 - service & defects
01/02/21	SC09 - c/o pos 3 tyre, belly plate bolts & apron t
01/02/21	SC09 - pos 3 tyre, apron trunnions & flip routers
01/02/21	SC09 - c/o pos 3 tyre
02/02/21	SC09 - wash rear engine radiator
04/02/21	SC09 - flat tyre
04/02/21	SC09 - pos 3 tyre leak& check o-ring
05/02/21	SC09 - strip, inspect & refit pos 3 tyre
05/02/21	SC09 - pos 3 tyre
05/02/21	SC09 - strip, inspect & refit pos 3 tyre
09/02/21	SC09 - c/o pos 3 tyre & inspect
09/02/21	SC09 - pos 3 tyre
10/02/21	SC09 - pos 3 tyre
12/02/21	SC09 - c/o servo cylinder

15/02/21	SC09 - pos 3 hub
16/02/21	SC09 - remove pos 3 tyre
18/02/21	SC09 - strip & clean final assembly
18/02/21	SC09 - pos 3 hub
18/02/21	SC09 - pos 3 final drive
19/02/21	SC09 - hub
03/03/21	SC09 - pos 3 brake assembly
10/03/21	SC09 - strip final & brakes
10/03/21	SC09 - strip final
11/03/21	SC09 - park brake switch
11/03/21	SC09 - park brake
12/03/21	SC09 - pos 3 assemble & c/o brake
12/03/21	SC09 - pos 3 final & tyre
12/03/21	SC09 - install pos 3 tyre
12/03/21	SC09 - pos 3 hub & tyre
15/03/21	SC09 - check over
18/03/21	SC09 - reassemble spare wheel end
07/04/21	SC09 - repairs
08/04/21	SC09 - remove broken bolt in slack adjuster
08/04/21	SC09 - pos 1 bolt & repair slack adjuster
08/04/21	SC09 - install pos 1 tyre & repair GPS antenna
11/05/21	Rear fan belt came off
12/05/21	Replace front engine belts & idlers
13/05/21	Trans hose oil leak & bowl lift cylinder
17/05/21	Install LH bowl lift cylinder
17/05/21	Cylinder rebuild & install
17/05/21	c/o trans cooler hoses, rebuild LH bowl lift cylin
18/05/21	Fabricate & install brackets for wheel chocks & cr
18/05/21	Wash
19/05/21	Crack repairs
07/06/21	wash, movement checks & samples
07/06/21	wash
08/06/21	repair air box
22/06/21	horn button
28/07/21	flip routers
28/07/21	flip routers
04/08/21	Repairs
10/08/21	Go line checks
19/08/21	swap over GPS screen
23/08/21	GPS fault
24/08/21	install new GPS screen
25/08/21	vibration
02/09/21	mine radio aerial fault
09/09/21	wash

09/09/21	cut out wear strips
10/09/21	replace wear strips & cutting edges
10/09/21	GET
13/09/21	tension rear engine drive belts & lift cylinder
13/09/21	fabricate & install front hand rail
13/09/21	service & defects
13/09/21	service, defects & bowl lift cylinder
16/09/21	bail arm cylinder bearings
16/09/21	R&R new bushes in cylinder
22/09/21	replace bearings in apron bracket
22/09/21	Replace bushes in lift arm bracket
29/09/21	apron lift cylinder & defects
29/09/21	apron cylinder & defects
04/10/21	fit bail arm & cylinder
04/10/21	bail arm & cylinder
13/10/21	brake assembly
13/10/21	pos 1 brake repair
13/10/21	pos 1 brake
14/10/21	pos 1 brake & assemble & install hub
14/10/21	pos 1 brake hub
14/10/21	pos 1 hub
15/10/21	GPS repairs
15/10/21	finish off pos 1 brake
15/10/21	adjust pos 1 brake
25/10/21	remove drive shaft
25/10/21	hydraulic leak
26/10/21	remove power pack & split trans
26/10/21	remove rear transmission
26/10/21	wash, replace push pad & crack repairs
26/10/21	remove power pack & trans
27/10/21	reseal & remove rod & head on bowl lift cylinder
27/10/21	parts
27/10/21	wear strips on rhino hook & R&R pin & bushes lift
27/10/21	reseal lift cylinder & clean up
28/10/21	Steer cylinder reseal/removal
28/10/21	Install & reseal Steer Cylinder
28/10/21	Assist on Job
28/10/21	Steer Cylinder & Bowl Lift
29/10/21	parts
03/11/21	trans & organise parts
08/11/21	fab mounting bracket for engine stand
09/11/21	engine stand modifications
10/11/21	wash
10/11/21	engine stand mods

06/12/21	Order parts
07/12/21	Remove backing and clean
08/12/21	Dissassemble Transmission
09/12/21	Assemble Transmission
10/12/21	Rebuild
24/01/22	Assemble planetary packs
25/01/22	Check over transmission
03/02/22	Remove bal arm and wash
21/02/22	Clean parts and assemble transmission
22/02/22	Reseal transmission, PU parts
23/02/22	Assemble Transmission
24/02/22	Assemble transmission
25/02/22	Assemble transmission
25/02/22	Fit out power pack
01/03/22	Run up rear engine
01/03/22	Pressure Test Transmission
07/03/22	Transmission pressure test, lube, pump, air gauge
10/03/22	Electrical fault
10/03/22	Electrical issues
11/03/22	electrical fault
11/03/22	warning issue
15/03/22	Refit all removed panels+belly guard
15/03/22	Electrical fault
15/03/22	Electrical fault repair
15/03/22	Gps
17/03/22	Steering Hoses
13/04/22	Rectify air leak and damage to mudguard
13/04/22	Bogged and damaged
14/04/22	Recover from pit
14/04/22	Recover from pit
19/04/22	itch Clean Up
20/04/22	Remove P1 guard and support/ remove broken bolts
21/04/22	Repair and re mount trans SOL cover
21/04/22	Roller
22/04/22	Fit parts/ re fit mudguard mount ready for fitting
22/04/22	Repair mud guard mounts
27/04/22	C/O steer housing from under cab to hitch/ mudguard
27/04/22	Hitch Repairs
27/04/22	Fit P1 guard Tyre/ adjust brakes
27/04/22	Hoses/ guards/Tyre
28/04/22	Rebuild Servo Cylinder
29/04/22	Clean up, inspect scraper hitch, rollers
03/05/22	Clean Hitch Cylinder
06/05/22	Clean up Hitch

09/05/22	Rebuild hitch
09/05/22	Assemble hitch
10/05/22	Rebuild Hitch
10/05/22	Hitch Assembly
16/05/22	Rebuild hitch
16/05/22	Hitch assembly
17/05/22	Hitch assembly
17/05/22	Hitch assembly
26/05/22	Rebuild hitch cylinder
26/05/22	Rebuild hitch cylinders
26/05/22	Torque converter parts
27/05/22	Rebuild hitch
27/05/22	Assemble hitch, collect parts
30/05/22	Hitch rebuild
14/06/22	Torque Converter
16/06/22	Tune up rear engine
21/06/22	Rear torque connector.
23/06/22	Reseal hydraulic cylinder, clean and reseal torque
27/06/22	Tone up Front Engine, Belly Guard
27/06/22	Tear Trans Cooler Chang Over
27/06/22	Service & Defects
28/06/22	Belly Guard Install Covers Run & Test
28/06/22	Defects
28/06/22	Service & Defects
12/07/22	Hose replacement on hitch
12/07/22	Hydraulic hose
21/07/22	Seat fault
21/07/22	Seat fault Scraper
27/07/22	Repairs
27/07/22	Oils and air leak
28/07/22	Park brake fault
08/08/22	Seat issues
07/09/22	GPS
08/09/22	GPS issue
08/09/22	GPS Fault
29/09/22	Torque connector assemble
26/10/22	GPS
28/10/22	Indicator and seat repair
02/11/22	Flip GET/ Routers/ stinger and edges
02/11/22	Change out quick release air valve
02/11/22	Wash, rmove and clean flip GET and routers
14/11/22	Defects
30/11/22	Remove 2 way and antenna/ lead and replace
01/12/22	Fit Acuator hose

01/12/22	Oil levels
08/12/22	Fire extinguisher bracket
13/12/22	Steps
19/12/22	Repair mine radio
20/12/22	Pack up hitch for QLD, load onto truck
04/01/23	Hitch components
09/01/23	Take hitch to heywood
16/01/23	Deects heater taps, change out seat, check fluid
19/01/23	Change out rear eng drive belts
24/01/23	Mud guard repairs
24/01/23	P1 Guard repair
25/01/23	Repair mud guard
25/01/23	Guard repair
25/01/23	GET
31/01/23	Broken Guards
02/02/23	Dismantle hitch
02/02/23	Wash hitch and trans set up machine/ drain fluids
02/02/23	Remove bail arm, disassemble tractor/scraper
02/02/23	remove and disassemble hitch
02/02/23	Split machine
02/02/23	Wash
03/02/23	C/O Hitch removal
03/02/23	Hitch removal C/O trans
03/02/23	C/O hitch
06/02/23	Guard removal
06/02/23	Prep hitch remove bush's
06/02/23	Hitch repair
07/02/23	C/O hitch repairs
07/02/23	Hitch cylinder repair
08/02/23	Fabrication L/H mudguard
08/02/23	Prep and fit pump drive and hosing, prep hitch
08/02/23	Refit Gear drive to rear of trans
09/02/23	Hitch/ new hose installation
09/02/23	Remove old and replace new hitch
09/02/23	Hitch repairs
09/02/23	Hitch repairs
10/02/23	Hitch installation
10/02/23	Prep and fit hitch
10/02/23	Hitch install
10/02/23	SC09 spotter
22/02/23	Assemble hitch
22/02/23	Prep hitch/ scraper to be joined
22/02/23	Join tractor and scraper
22/02/23	Prep for joining machine

22/02/23	Join tractor to scraper
23/02/23	Continue putting machine back together
23/02/23	Hitch
23/02/23	Trnsion hitch pins, graese lines C/O
23/02/23	hitch repairs
24/02/23	Hitch repairs
24/02/23	Hitch repairs
27/02/23	Jack up, remove POS1 hose under hitch tec
27/02/23	Hitch repairs
28/02/23	C/O wiper stalk
28/02/23	Fit new hoses
28/02/23	Rear trans C/O
01/03/23	Remove Wheelend and drill holes in Mudguard
01/03/23	Remove P1 axle drain/ drain oils remove wheel end
01/03/23	Hub repair
02/03/23	Paint guard
02/03/23	Install final drive
02/03/23	Install mudguard POS 1
02/03/23	Fit tyre POS 1
02/03/23	Fit threads to diff housing/ studs/ fit bracket
02/03/23	Wheel ends/ tension/ fit axle brake booster grease
02/03/23	Fit mud guard/ back and fit grease pod
02/03/23	Fit tread inserts to diff housing
02/03/23	Fit wheel end, tension bolts
06/03/23	Top up Hyd oil/ trans and diff
07/03/23	Fill diff/ ourge grease sys and fill oils run up-
07/03/23	Shim Hitch- rear horizontal pin/ adjust tyre
07/03/23	Purge grease system
07/03/23	Finish hitch repairs/ wiring/hoses
07/03/23	Complete hitch install- bleed steering/ adjust bra
08/03/23	Mud flaps
08/03/23	Fill P1 oil and top up trans
08/03/23	Rectify brakes- not releasing
29/03/23	C/O park brake solenoid
15/05/23	Jump start rear engine
23/05/23	Check and adjust hitch pressures
23/05/23	Fit external radio speaker
05/06/23	Check ove, jump start rear engine
05/07/23	Isolator maintenance, remove battery and assembly
06/07/23	Remove/ install isolator- ignition
13/07/23	Install isolator and batteries
17/08/23	Replace batteries rear engine
02/10/23	Electrical fault
03/10/23	Joystick elec fault- replace stack

04/10/23	Engine light and check dash cam
09/10/23	replace Ac blower
10/10/23	Hydraulic Fault
11/10/23	Steering Fault
12/10/23	Joystick fault
13/10/23	Joystick change out
17/10/23	Steering fault
18/10/23	Replace trans speed sensors
18/10/23	Inspect steering fault
23/10/23	Replace retarder valve and diff lock valve
26/10/23	Repair bowl lift cylinder retainer/ free up pin
27/10/23	Replace GET
30/10/23	Fabricate plates/ decals
03/11/23	Plant Cert form
17/11/23	Hyd hose
20/11/23	Hyd Hose- Steer hose
23/11/23	Rear decal fabrication and installation
27/11/23	Rear engine, install alternator, belts, etc
01/12/23	Defects, C/O fuel pressure regulator rear engine
06/12/23	Recover scraper Pit 23
07/12/23	trans fault, remove trans screens- inspect
07/12/23	Fault code
08/12/23	Drain trans, pull screens+ filter- metal in filter
14/12/23	transmission Fault
14/12/23	Wash
14/12/23	Trans Fault
14/12/23	Pats List
15/12/23	Wash and move
15/12/23	Order parts SC09 fron trans
18/12/23	Drain Hyd, trans, diff and evac
18/12/23	Remove hitch pump, hyd pumps, drive shaft etc
18/12/23	Remove trans, wash, load, seal diff housing
18/12/23	Remove Transmission
18/12/23	Remove Transmission
19/12/23	Disassemble transmission
20/12/23	Disassemble, clean and inspect
20/12/23	Collect parts/ clean inspect torque converter
20/12/23	Clean/ inspect parts, planterys- part lists
21/12/23	Clean and inspect, replace hoses, drop at WA
21/12/23	Disassemble control valve, rotary sensor valve
21/12/23	Parts list, grease up second hand parts, clean par
04/01/24	Clean and buff hoses, collect parts from William A
04/01/24	Clean gears, assemble transfer gear, sort parts
05/01/24	Clean parts, collect parts from WA, drop off hose

05/01/24	Clean hoses, shafts for assembly
05/01/24	Clean torque con parts for assembly, buff and clea
08/01/24	Assemble fron transmission
09/01/24	Clean parts, assemble transmission
10/01/24	Assemble Transmission
11/01/24	Assemble transmission
22/01/24	Assemble Transimission
23/01/24	Assemble Transmission
24/01/24	Assemble transmission
25/01/24	Assemble/ prepare for and take to transport compan
29/01/24	Remove belly guard- transmission
30/01/24	Clean out diff housing, transmission clean etc
05/02/24	Assist with trans fitment, paperwork
05/02/24	Load transmission and travel to Douglas
05/02/24	Buff, clean Diff housing, install o rings
05/02/24	JHA's install transmission
06/02/24	Install pumps suction lines
06/02/24	Install hyd lines
06/02/24	Filter base hyd lines, connect ET- run and test
06/02/24	Transmission installation
06/02/24	Levels in SC09
07/02/24	Drive Fault
07/02/24	Test Machine, Troubshoot vibration, check retarder
08/02/24	Assist with retarder removal/ wash load parts
08/02/24	Faults- Slip clutch failed
09/02/24	Dissassemble retarder housing, clean
12/02/24	Rear main seal
13/02/24	Clean housing and crank shaft
13/02/24	Install main seal, fly wheel etc
13/02/24	Assist with flywheel install
14/02/24	Clean parts disassemble, assemble, new bearings
15/02/24	Load parts/ wrap and seal
15/02/24	Assemble retarder
15/02/24	Install retarder, housing etc
15/02/24	Assist with fitting retarder
16/02/24	Slip cluth hose
16/02/24	Top up oils, test, install belly guard
21/02/24	Engine fault
22/02/24	Engine fault
27/02/24	Replace dust ejector hose and pit 10 fuel run
05/03/24	Refit Apron lift arm onto trunnion
08/03/24	Rebuild hitch cyclinder
20/03/24	Rear engine belts
20/03/24	Rear engine belts

10/04/24	Replace Trunions and hyd hose
10/04/24	Replace apron trunnions, caps, 2x hyd hoses
15/04/24	Replace blown hose
29/04/24	Replace GPS cradle
19/06/24	Replace radio hand piece
24/06/24	Filter restriction fault
25/06/24	Replace GET2.5
25/06/24	Fit scraper chassis harness
02/07/24	Change rear alternator belt and pulley @ Pit
09/07/24	Engine light - Front air filter
24/07/24	Inspect machine/ order parts
24/07/24	Move to wash bay and wash
25/07/24	Fix GPS not powering up
25/07/24	Inspect for defects/ remove hydraulic hose above h
25/07/24	Replace hyd hose, order parts, replace mud flap,
29/07/24	Front engine exhaust manifold re seal
30/07/24	Exhaust manifold re seal, rocker covers re seal
31/07/24	exhaust manifold re seal
01/08/24	Finish exhaust manifold
12/08/24	Seat repairs
12/08/24	Seat repairs
13/08/24	Turbo drain hose, Repair wiring harness
14/08/24	Fit new boost hose and test
19/09/24	Breakdown in pit, damage to guard and trans line
20/09/24	Recover Scraper, Power trin lines
20/09/24	Defects in pit
23/09/24	Hydraulic hoses and defects
23/09/24	Recover machine from Pit
23/09/24	Fit temp hoses and recover from Pit23
24/09/24	R&R isolate
25/09/24	Tyre removal
25/09/24	Was PS1, move into workshop and jack up
26/09/24	Remove tyreStraighten guard bracket
26/09/24	Remove tyre P1, order parts, check trans
30/09/24	Hyd lines, power train hoses
30/09/24	Remove broken trans lines
01/10/24	Assemble machine, install pipe trans
01/10/24	Fit new pipes, inner guard, finish repairs
02/10/24	Collect parts from WA Hsm
07/10/24	Brake defect
08/10/24	Remove muffler, pre cleaner, c/o run up test
08/10/24	Replace muffler and pre cleaner
10/10/24	Straighten POS1 guard
14/10/24	Repalce leaking trans hose

17/10/24	Seat base, Draft arm pinions, order parts
17/10/24	Defect repairs, tidy workshop
18/10/24	Replace leaking trans hose, front engine, throttle
21/10/24	defects
21/10/24	Chase up belly guards, inspect- bent guards
21/10/24	make new trans hoses and fit
22/10/24	straighten belly plate and fit
22/10/24	RHS steering cylinder
22/10/24	Drill out broken rear belly plate bolts, re thread
23/10/24	Bowl trunions, cpas instal new bolts, torque to sp
23/10/24	Repair seat, finish fitting steer cylinder
23/10/24	Replace side arm trunions and caps, clean up
24/10/24	Install belly guard, steer cylinder pin- return
24/10/24	Belly plate installation
01/11/24	Engine light
11/11/24	Change out rear engine pedal
12/11/24	Inspect diff lock operation
12/11/24	Diff lock
13/11/24	cert forms
15/11/24	Check injector noise test
19/11/24	Inspect seat
20/11/24	Femove seat from machine/ disassemble
20/11/24	Seat repairs
21/11/24	Install seat return to work
21/11/24	Over heating rear engine
22/11/24	Wash out radiators front and rear, check over
03/12/24	Troubleshoot diff lock fault, order parts
04/12/24	Inspect, maintain air leaks, rear engine belts
04/12/24	Diff lock fault and air leak
13/12/24	Inspect diff lock, c/o switch soleinoid, defects
19/12/24	Clean out Radiators, filters
10/01/25	Remove Apron pin
10/01/25	Install apron pin
10/01/25	Replace apron pivot- apron arm pin
15/01/25	Clean out radiators, eplace air cleaners, inspect
15/01/25	Wash radiators/ change filters
22/01/25	Fabrication on body
29/01/25	removed and replaced blown hose
31/01/25	Cutting edges- order parts
31/01/25	GET inspection
31/01/25	GET C/O
04/02/25	Clean Radiators
10/02/25	Lift cylider, pin retainer, rear belts
10/02/25	Replace rear engine bolts

10/02/25	Radio dropping out
11/02/25	Apron cracks
12/02/25	Defects, apron
12/02/25	Apron defects/ wash
13/02/25	Apron repairs, return to work
26/02/25	Blown hose
28/02/25	Defects, adjust brakes, air cleaner
28/02/25	Defects
03/03/25	Wash rear engine/ radiator
13/03/25	Return to work, run up and test
13/03/25	Hydraulic oil leaks, lift cylinder
17/03/25	Check GPS
17/03/25	Checkover
20/03/25	Engine fault- replace air filter
25/03/25	Air con fault
31/03/25	GPS fault
31/03/25	Troubleshoot GPS fault
01/04/25	Troubleshoot/ repair GPS
02/04/25	Weld guard/ install guard
02/04/25	P1 guard repairs
08/04/25	GPS fault
08/04/25	Check GPS
09/04/25	Repair GPS
16/04/25	Hydraulic line repairs
16/04/25	Replace ejector roller
17/04/25	Troubleshoot code, changeout air fcleaners
17/04/25	AC repairs
29/04/25	Troubleshoot engine fault
29/04/25	Change out dust ejector tube, check during break
01/05/25	Adjust Brakes
01/05/25	P1 brake booster, adjust brakes
01/05/25	Replace P4 booster adjust brakes
02/05/25	Inspect fault code- relpace sensor
05/05/25	Clean out Radiator
05/05/25	Breakdown E-stop fault, in pit
06/05/25	Replace seat
07/05/25	Clean out radiators and air cleaners
09/05/25	Pos 2 Guard repairs
12/05/25	Air filters
14/05/25	Clean out radiators and air filters
15/05/25	Inspect scrapers, defects
15/05/25	Replace grease lines
16/05/25	Clean out rear radiator
19/05/25	Air leak- diff lock switch faulty

27/05/25	Air cleaners, check over machine
29/05/25	Derate fault
30/05/25	GPS fault
02/06/25	Fault codes- blocked air filter, replaced tail pip
05/06/25	oil leak fault
06/06/25	Change out G.E.T
06/06/25	G.E.T Stinger
06/06/25	Defect list
10/06/25	Machine defects
10/06/25	Defects/ diff oil/ rollers
11/06/25	Defects/ belt replacement/ pre cleaner replacement
12/06/25	Machine defects. Rollers
12/06/25	Repair signage SME repair bracket
18/06/25	Product link fault
24/06/25	Electrical fault, change cab mounts
24/06/25	Cab mounts- elec fault, vision link fault
14/07/25	Electrical fault
15/07/25	Data link fault
16/07/25	Machine Defects
16/07/25	Machine defects
29/07/25	Remove hitch harness
30/07/25	Hitch Harness
30/07/25	Replace hitch harness, Fit P1 tyre
07/08/25	Trans oil and Pos 4 wheel end oil levels
13/08/25	Washed to do duo cone seals
14/08/25	Remove POS 4 tyre
14/08/25	final drive
14/08/25	Remove wheel spindal, Duo cone seal, clean parts
14/08/25	Assemble wheel end and final drive, Install tyre
14/08/25	Duo cone seal stripped POS 4 final drive
14/08/25	Clean components to re assemble
14/08/25	Re assemble filled oil tested- ok
19/08/25	Electrical Fault
20/08/25	Remove GPS screen to fit to SC18
22/08/25	Insepect rollers
25/08/25	Inspected rollers/ ordered parts
26/08/25	Roller change out
27/08/25	Machine defects- Samples
27/08/25	Finish off sampling oils, replace wiper blades
04/09/25	Machine defects, check over belts, pulley, check
15/09/25	Troubleshoot fuel pressure fault
15/09/25	Electrical fault
16/09/25	Diagnose fault codes
22/09/25	Fit Step

30/09/25	Checkover, fault codes, hyd breather
03/10/25	Check over, C/O Hyd/ trans breather
08/10/25	Hydraulic oil leaks
08/10/25	Oil leak
10/10/25	Change out rear engine fuel pressure sensor
10/10/25	Grease fault
13/10/25	Grease line repairs/ test
14/10/25	grease live fitting
16/10/25	Replace ejector floor roller
22/10/25	Wash machine for repairs
22/10/25	Check over, remove belly plates, oil leaks
23/10/25	Repair front transmission oil leak
23/10/25	replace rear engine belts and tensioner/ trans oil
27/10/25	Change out cooler retarder lines
27/10/25	Door Repairs fabrication/ Bonnet Fabrication
27/10/25	Install belly guard/ fit door
07/11/25	Prep machine for service, organise filters, parts
10/11/25	G.E.T c/o
18/11/25	Cert form check over
21/11/25	Machne defects. Hydraulic oil leaks
21/11/25	Inspection/ clean ari cleaners
24/11/25	Cert form- check over
26/11/25	G.E.T inspection
26/11/25	GET/ machine inspection
01/12/25	Machine defects/ troubleshoot elec fault
01/12/25	Wiring fault
02/12/25	Troubleshoot data link fault
02/12/25	Electrtical fault
03/12/25	Product link fault
03/12/25	Air fault- Troubleshoot
03/12/25	Diagnose electrical fault- tested (ok)
03/12/25	Diagnose and repaired air leak
09/12/25	GPS fault
11/12/25	Air con switch
12/12/25	Start fault
15/12/25	Clean out radiator

Plant No	Site	Work Type	labourHour	Plant Type	Task
SC09	South	Maintena	6.00	Powered	nce Fitter
SC09	South	Maintena	0.50	Powered	nce Fitter
SC09	South	Maintena	9.00	Powered	nce Fitter
SC09	South	Maintena	7.50	Powered	nce Fitter
SC09	South	Maintena	9.00	Powered	nce Fitter
SC09	South	Maintena	8.50	Powered	nce Fitter
SC09	South	Maintena	5.00	Powered	nce Fitter
SC09	South	Maintena	4.00	Powered	nce Fitter
SC09	South	Maintena	2.00	Powered	nce Fitter
SC09	South	Maintena	0.50	Powered	nce Fitter
SC09	South	Maintena	0.50	Powered	nce Fitter
SC09	South	Maintena	0.50	Powered	nce Fitter
SC09	South	Maintena	0.50	Powered	nce Fitter
SC09	South	Maintena	1.50	Powered	nce Fitter
SC09	South	Maintena	2.50	Powered	nce Fitter
SC09	South	Maintena	1.50	Powered	nce Fitter
SC09	South	Maintena	1.00	Powered	nce Fitter
SC09	South	Maintena	6.00	Powered	nce Fitter
SC09	South	Maintena	2.00	Powered	nce Fitter
SC09	South	Maintena	2.00	Powered	nce Fitter
SC09	South	Maintena	0.50	Powered	nce Fitter
SC09	South	Maintena	3.00	Powered	nce Fitter
SC09	South	Maintena	0.50	Powered	nce Fitter
SC09	South	Maintena	1.50	Powered	nce Fitter
SC09	South	Maintena	1.50	Powered	nce Fitter
SC09	South	Maintena	4.00	Powered	nce Fitter
SC09	South	Maintena	6.50	Powered	nce Fitter
SC09	South	Maintena	6.50	Powered	nce Fitter
SC09	South	Maintena	1.50	Powered	nce Fitter
SC09	South	Maintena	1.50	Powered	nce Fitter
SC09	South	Maintena	3.50	Powered	nce Fitter
SC09	South	Maintena	3.50	Powered	nce Fitter
SC09	South	Maintena	1.50	Powered	nce Fitter
SC09	South	Maintena	1.00	Powered	nce Fitter
SC09	South	Maintena	1.00	Powered	nce Fitter
SC09	South	Maintena	2.00	Powered	nce Fitter
SC09	South	Maintena	1.00	Powered	nce Fitter
SC09	South	Maintena	1.00	Powered	nce Fitter
SC09	South	Maintena	1.00	Powered	nce Fitter
SC09	South	Maintena	2.00	Powered	nce Fitter
SC09	South	Maintena	2.50	Powered	nce Fitter
SC09	South	Maintena	1.00	Powered	nce Fitter
SC09	South	Maintena	0.50	Powered	nce Fitter

SC09	South	Maintena	1.50	Powered	nce Fitter
SC09	South	Maintena	1.00	Powered	nce Fitter
SC09	South	Maintena	3.00	Powered	nce Fitter
SC09	South	Maintena	1.00	Powered	nce Fitter
SC09	South	Maintena	3.00	Powered	nce Fitter
SC09	South	Maintena	2.50	Powered	nce Fitter
SC09	South	Maintena	2.50	Powered	nce Fitter
SC09	South	Maintena	4.00	Powered	nce Fitter
SC09	South	Maintena	5.50	Powered	nce Fitter
SC09	South	Maintena	1.00	Powered	nce Fitter
SC09	South	Maintena	2.50	Powered	nce Fitter
SC09	South	Maintena	8.00	Powered	nce Fitter
SC09	South	Maintena	3.00	Powered	nce Fitter
SC09	South	Maintena	1.00	Powered	nce Fitter
SC09	South	Maintena	9.50	Powered	nce Fitter
SC09	South	Maintena	1.00	Powered	nce Fitter
SC09	South	Maintena	4.00	Powered	nce Fitter
SC09	South	Maintena	2.00	Powered	nce Fitter
SC09	South	Maintena	3.00	Powered	nce Fitter
SC09	South	Maintena	5.00	Powered	nce Fitter
SC09	South	Maintena	2.00	Powered	nce Fitter
SC09	Workshop	Maintena	0.50	Powered	Repairs &
SC09	Workshop	Maintena	4.00	Powered	Repairs &
SC09	Workshop	Maintena	3.00	Powered	Repairs &
SC09	Workshop	Maintena	1.00	Powered	Repairs &
SC09	Workshop	Maintena	2.50	Powered	Repairs &
SC09	Workshop	Maintena	8.00	Powered	Repairs &
SC09	Workshop	Maintena	6.75	Powered	Repairs &
SC09	Workshop	Maintena	2.00	Powered	Workshop
SC09	Workshop	Maintena	2.00	Powered	Repairs &
SC09	Workshop	Maintena	2.00	Powered	Workshop
SC09	Workshop	Maintena	0.50	Powered	Workshop
SC09	Workshop	Maintena	3.00	Powered	Repairs &
SC09	Workshop	Maintena	0.50	Powered	Repairs &
SC09	Workshop	Maintena	0.50	Powered	Repairs &
SC09	Workshop	Maintena	0.50	Powered	Repairs &
SC09	Workshop	Labour	5.50	Powered	Repairs &
SC09	Workshop	Maintena	1.00	Powered	Repairs &
SC09	Workshop	Maintena	0.50	Powered	Repairs &
SC09	Workshop	Maintena	2.50	Powered	Repairs &
SC09	Workshop	Maintena	1.00	Powered	Repairs &
SC09	Workshop	Maintena	0.50	Powered	Repairs &
SC09	Workshop	Maintena	0.50	Powered	Repairs &
SC09	Workshop	Maintena	1.00	Powered	Workshop

SC09	Workshop	Maintena	3.50	Powered	Repairs &
SC09	Workshop	Maintena	9.00	Powered	Repairs &
SC09	Workshop	Maintena	0.50	Powered	Repairs &
SC09	Workshop	Maintena	7.50	Powered	Repairs &
SC09	Workshop	Maintena	5.00	Powered	Repairs &
SC09	Workshop	Maintena	4.00	Powered	Repairs &
SC09	Workshop	Maintena	8.50	Powered	Repairs &
SC09	Workshop	Maintena	1.00	Powered	Repairs &
SC09	Workshop	Maintena	2.00	Powered	Repairs &
SC09	Workshop	Maintena	2.00	Powered	Repairs &
SC09	Workshop	Maintena	1.00	Powered	Repairs &
SC09	Workshop	Maintena	6.00	Powered	Repairs &
SC09	Workshop	Maintena	3.50	Powered	Repairs &
SC09	Workshop	Maintena	2.00	Powered	Repairs &
SC09	Workshop	Maintena	1.50	Powered	Repairs &
SC09	South	Maintena	1.25	Powered	nce Fitter
SC09	Workshop	Maintena	3.00	Powered	Repairs &
SC09	Workshop	Maintena	2.00	Powered	Repairs &
SC09	Workshop	Maintena	1.00	Powered	Repairs &
SC09	Workshop	Maintena	3.50	Powered	Repairs &
SC09	Workshop	Maintena	3.50	Powered	Repairs &
SC09	Workshop	Maintena	2.00	Powered	Repairs &
SC09	Workshop	Maintena	3.00	Powered	Repairs &
SC09	Workshop	Maintena	3.00	Powered	Repairs &
SC09	Workshop	Maintena	0.50	Powered	Repairs &
SC09	Workshop	Maintena	1.00	Powered	Repairs &
SC09	Workshop	Maintena	6.50	Powered	Repairs &
SC09	Workshop	Maintena	4.00	Powered	Repairs &
SC09	Workshop	Maintena	8.00	Powered	Repairs &
SC09	Workshop	Maintena	7.50	Powered	Repairs &
SC09	Workshop	Maintena	7.50	Powered	Repairs &
SC09	Workshop	Maintena	3.50	Powered	Workshop
SC09	Workshop	Maintena	6.00	Powered	Repairs &
SC09	Workshop	Maintena	2.00	Powered	Repairs &
SC09	Workshop	Maintena	1.00	Powered	Repairs &
SC09	Workshop	Maintena	2.50	Powered	Repairs &
SC09	Workshop	Maintena	2.00	Powered	Workshop
SC09	Workshop	Maintena	3.00	Powered	Repairs &
SC09	Workshop	Maintena	2.00	Powered	Workshop
SC09	Workshop	Maintena	1.50	Powered	Repairs &
SC09	Workshop	Maintena	2.50	Powered	Repairs &
SC09	Workshop	Maintena	2.00	Powered	Repairs &
SC09	Workshop	Maintena	2.00	Powered	Workshop
SC09	Workshop	Maintena	1.00	Powered	Repairs &

SC09	Workshop	Labour	3.50	Powered	Repairs &
SC09	Workshop	Labour	6.00	Powered	Repairs &
SC09	Workshop	Labour	9.50	Powered	Repairs &
SC09	Workshop	Labour	5.00	Powered	Repairs &
SC09	Workshop	Labour	7.00	Powered	Repairs &
SC09	Workshop	Labour	1.50	Powered	Repairs &
SC09	Workshop	Labour	7.00	Powered	Repairs &
SC09	Workshop	Labour	1.00	Powered	Repairs &
SC09	Workshop	Labour	7.50	Powered	Repairs &
SC09	Workshop	Labour	8.00	Powered	Repairs &
SC09	Workshop	Labour	10.00	Powered	Repairs &
SC09	Workshop	Labour	10.00	Powered	Repairs &
SC09	Workshop	Labour	3.00	Powered	Repairs &
SC09	Workshop	Labour	6.00	Powered	Repairs &
SC09	Workshop	Labour	2.00	Powered	Repairs &
SC09	Workshop	Labour	1.00	Powered	Repairs &
SC09	Workshop	Maintena	4.00	Powered	Repairs &
SC09	Workshop	Maintena	1.50	Powered	Repairs &
SC09	Workshop	Maintena	2.00	Powered	Repairs &
SC09	Workshop	Maintena	3.50	Powered	Repairs &
SC09	Workshop	Maintena	3.00	Powered	Repairs &
SC09	Workshop	Maintena	1.00	Powered	Repairs &
SC09	Workshop	Maintena	4.00	Powered	Repairs &
SC09	Workshop	Maintena	2.50	Powered	Repairs &
SC09	Workshop	Maintena	3.00	Powered	Repairs &
SC09	Workshop	Maintena	4.00	Powered	Repairs &
SC09	Workshop	Maintena	2.00	Powered	Repairs &
SC09	Workshop	Maintena	2.00	Powered	Repairs &
SC09	Workshop	Maintena	1.00	Powered	Repairs &
SC09	Workshop	Maintena	1.00	Powered	Repairs &
SC09	Workshop	Maintena	2.00	Powered	Repairs &
SC09	Workshop	Maintena	3.50	Powered	Repairs &
SC09	Workshop	Maintena	1.00	Powered	Repairs &
SC09	Workshop	Maintena	0.50	Powered	Repairs &
SC09	Workshop	Maintena	1.50	Powered	Repairs &
SC09	Workshop	Maintena	1.50	Powered	Repairs &
SC09	Workshop	Maintena	5.50	Powered	Repairs &
SC09	Workshop	Labour	7.00	Powered	Repairs &
SC09	Workshop	Maintena	2.00	Powered	Repairs &
SC09	Workshop	Maintena	5.50	Powered	Repairs &
SC09	Workshop	Labour	4.00	Powered	Repairs &
SC09	Workshop	Maintena	5.00	Powered	Repairs &
SC09	Workshop	Labour	1.00	Powered	Repairs &
SC09	Workshop	Labour	1.00	Powered	Repairs &

SC09	Workshop	Maintena	3.00	Powered	Repairs &
SC09	Workshop	Maintena	3.50	Powered	Repairs &
SC09	Workshop	Labour	4.50	Powered	Repairs &
SC09	Workshop	Labour	4.50	Powered	Workshop
SC09	Workshop	Maintena	3.50	Powered	Reconditi
SC09	Workshop	Maintena	3.50	Powered	Reconditi
SC09	Workshop	Maintena	2.00	Powered	Repairs &
SC09	Workshop	Maintena	7.50	Powered	Repairs &
SC09	Workshop	Maintena	2.50	Powered	Reconditi
SC09	Workshop	Maintena	2.50	Powered	Repairs &
SC09	Workshop	Maintena	2.00	Powered	Repairs &
SC09	Workshop	Maintena	7.50	Powered	Reconditi
SC09	Workshop	Maintena	3.50	Powered	Repairs &
SC09	Workshop	Maintena	1.00	Powered	Repairs &
SC09	Horsham	Maintena	1.00	Powered	Repairs &
SC09	Workshop	Maintena	3.00	Powered	Repairs &
SC09	Horsham	Maintena	3.50	Powered	Repairs &
SC09	Workshop	Maintena	3.00	Powered	Repairs &
SC09	Workshop	Labour	6.50	Powered	Repairs &
SC09	Workshop	Labour	6.50	Powered	Repairs &
SC09	Workshop	Maintena	2.50	Powered	Repairs &
SC09	Workshop	Labour	2.00	Powered	Repairs &
SC09	Workshop	Labour	3.00	Powered	Repairs &
SC09	Workshop	Maintena	3.50	Powered	Repairs &
SC09	Workshop	Maintena	3.50	Powered	Repairs &
SC09	Workshop	Maintena	3.00	Powered	Repairs &
SC09	Workshop	Maintena	1.00	Powered	Repairs &
SC09	Douglas	Labour	0.40	Powered	Workshop
SC09	Workshop	Maintena	1.50	Powered	Repairs &
SC09	Workshop	Maintena	7.00	Powered	Repairs &
SC09	Workshop	Maintena	2.00	Powered	Repairs &
SC09	Workshop	Maintena	1.50	Powered	Repairs &
SC09	Workshop	Maintena	0.50	Powered	Repairs &
SC09	Workshop	Maintena	1.50	Powered	Repairs &
SC09	Workshop	Maintena	3.50	Powered	Repairs &
SC09	Horsham	Maintena	6.50	Powered	Repairs &
SC09	Workshop	Maintena	1.50	Powered	Repairs &
SC09	Workshop	Maintena	2.00	Powered	Repairs &
SC09	Workshop	Maintena	3.50	Powered	Repairs &
SC09	Workshop	Maintena	2.00	Powered	Repairs &
SC09	Workshop	Maintena	3.00	Powered	Repairs &
SC09	Workshop	Maintena	0.60	Powered	Repairs &
SC09	Workshop	Maintena	1.50	Powered	Repairs &
SC09	Workshop	Maintena	0.50	Powered	Repairs &

SC09	Horsham	Maintena	3.50	Powered	Repairs &
SC09	Horsham	Maintena	4.00	Powered	Repairs &
SC09	Horsham	Maintena	8.50	Powered	Repairs &
SC09	Horsham	Maintena	8.00	Powered	Repairs &
SC09	Workshop	Maintena	10.50	Powered	Repairs &
SC09	Horsham	Maintena	4.00	Powered	Repairs &
SC09	Horsham	Maintena	10.50	Powered	Repairs &
SC09	Horsham	Maintena	10.50	Powered	Repairs &
SC09	Horsham	Maintena	10.50	Powered	Repairs &
SC09	Horsham	Maintena	8.50	Powered	Repairs &
SC09	Workshop	Maintena	6.50	Powered	Repairs &
SC09	Workshop	Maintena	9.00	Powered	Repairs &
SC09	Workshop	Maintena	2.50	Powered	Repairs &
SC09	Workshop	Maintena	1.00	Powered	Repairs &
SC09	Workshop	Maintena	2.00	Powered	Repairs &
SC09	Workshop	Maintena	3.50	Powered	Repairs &
SC09	Workshop	Maintena	2.50	Powered	Repairs &
SC09	Workshop	Maintena	3.50	Powered	Repairs &
SC09	Workshop	Maintena	4.00	Powered	Repairs &
SC09	Workshop	Maintena	1.00	Powered	Repairs &
SC09	Workshop	Maintena	1.00	Powered	Repairs &
SC09	Workshop	Maintena	1.50	Powered	Repairs &
SC09	Workshop	Maintena	7.00	Powered	Repairs &
SC09	Workshop	Maintena	2.00	Powered	Repairs &
SC09	Workshop	Maintena	8.50	Powered	Repairs &
SC09	Workshop	Maintena	3.00	Powered	Repairs &
SC09	Workshop	Maintena	2.00	Powered	Repairs &
SC09	Workshop	Maintena	1.50	Powered	Repairs &
SC09	Workshop	Maintena	3.50	Powered	Repairs &
SC09	Workshop	Maintena	1.00	Powered	Repairs &
SC09	Horsham	Maintena	3.00	Powered	Repairs &
SC09	Horsham	Maintena	1.00	Powered	Repairs &
SC09	Horsham	Maintena	1.00	Powered	Repairs &
SC09	Workshop	Maintena	6.50	Powered	Repairs &
SC09	Workshop	Maintena	1.50	Powered	Repairs &
SC09	Workshop	Maintena	3.00	Powered	Repairs &
SC09	Workshop	Maintena	3.00	Powered	Repairs &
SC09	Workshop	Maintena	1.50	Powered	Repairs &
SC09	Workshop	Maintena	1.00	Powered	Repairs &
SC09	Workshop	Maintena	1.50	Powered	Repairs &
SC09	Workshop	Maintena	1.50	Powered	Repairs &
SC09	Workshop	Maintena	2.00	Powered	Repairs &
SC09	Workshop	Maintena	2.00	Powered	Repairs &
SC09	Workshop	Maintena	3.00	Powered	Repairs &

Date	Work Description	Plant No	Work Type
24/01/19	SC09 - replace hyd hose	SC09	Plant Maintenance Labour
11/08/20	SC09 - brake repairs	SC09	Plant Maintenance Labour
23/09/20	SC09 - service & start front engine tune up	SC09	Plant Maintenance Labour
23/09/20	SC09 - service	SC09	Plant Maintenance Labour
24/09/20	SC09 - front engine tune up & service	SC09	Plant Maintenance Labour
24/09/20	SC09 - service	SC09	Plant Maintenance Labour
25/09/20	SC09 - seat wiring & pressure sensor	SC09	Plant Maintenance Labour
28/09/20	SC09 - remove seat & harness & test batteries	SC09	Plant Maintenance Labour
28/09/20	SC09 - repairs	SC09	Plant Maintenance Labour
29/09/20	SC09 - jump start machine	SC09	Plant Maintenance Labour
13/10/20	SC09 - c/o routers	SC09	Plant Maintenance Labour
13/10/20	SC09 - c/o cutting edges	SC09	Plant Maintenance Labour
21/10/20	SC09 - repace load counter	SC09	Plant Maintenance Labour
30/10/20	SC09 - rotate GET	SC09	Plant Maintenance Labour
30/10/20	SC09 - rotate edges & flashing light holder	SC09	Plant Maintenance Labour
04/11/20	SC09 - flat batteries	SC09	Plant Maintenance Labour
10/11/20	SC09 - mine radio & reversing camera elect fault	SC09	Plant Maintenance Labour
13/11/20	SC09 - wash, service & defects	SC09	Plant Maintenance Labour
13/11/20	SC09 - service	SC09	Plant Maintenance Labour
03/12/20	SC09 - c/o trans hose	SC09	Plant Maintenance Labour
08/12/20	SC09 - fan belt repairs	SC09	Plant Maintenance Labour
09/12/20	SC09 - rear engine belts & engine bay door	SC09	Plant Maintenance Labour
15/12/20	SC09 - repairs	SC09	Plant Maintenance Labour
15/12/20	SC09 - lift cylinder hoses	SC09	Plant Maintenance Labour
15/12/20	SC09 - blown hoses	SC09	Plant Maintenance Labour
14/01/21	SC09 - repair wiring & hose for grease fault	SC09	Plant Maintenance Labour
27/01/21	SC09 - service	SC09	Plant Maintenance Labour
27/01/21	SC09 - service & defects	SC09	Plant Maintenance Labour
28/01/21	SC09 - service	SC09	Plant Maintenance Labour
28/01/21	SC09 - service & defects	SC09	Plant Maintenance Labour
01/02/21	SC09 - c/o pos 3 tyre, belly plate bolts & apron t	SC09	Plant Maintenance Labour
01/02/21	SC09 - pos 3 tyre, apron trunnions & flip routers	SC09	Plant Maintenance Labour
01/02/21	SC09 - c/o pos 3 tyre	SC09	Plant Maintenance Labour
02/02/21	SC09 - wash rear engine radiator	SC09	Plant Maintenance Labour
04/02/21	SC09 - flat tyre	SC09	Plant Maintenance Labour
04/02/21	SC09 - pos 3 tyre leak& check o-ring	SC09	Plant Maintenance Labour
05/02/21	SC09 - strip, inspect & refit pos 3 tyre	SC09	Plant Maintenance Labour
05/02/21	SC09 - pos 3 tyre	SC09	Plant Maintenance Labour
05/02/21	SC09 - strip, inspect & refit pos 3 tyre	SC09	Plant Maintenance Labour
09/02/21	SC09 - c/o pos 3 tyre & inspect	SC09	Plant Maintenance Labour
09/02/21	SC09 - pos 3 tyre	SC09	Plant Maintenance Labour
10/02/21	SC09 - pos 3 tyre	SC09	Plant Maintenance Labour
12/02/21	SC09 - c/o servo cylinder	SC09	Plant Maintenance Labour
15/02/21	SC09 - pos 3 hub	SC09	Plant Maintenance Labour
16/02/21	SC09 - remove pos 3 tyre	SC09	Plant Maintenance Labour
18/02/21	SC09 - strip & clean final assembly	SC09	Plant Maintenance Labour
18/02/21	SC09 - pos 3 hub	SC09	Plant Maintenance Labour
18/02/21	SC09 - pos 3 final drive	SC09	Plant Maintenance Labour
19/02/21	SC09 - hub	SC09	Plant Maintenance Labour
03/03/21	SC09 - pos 3 brake assembly	SC09	Plant Maintenance Labour
10/03/21	SC09 - strip final & brakes	SC09	Plant Maintenance Labour
10/03/21	SC09 - strip final	SC09	Plant Maintenance Labour
11/03/21	SC09 - park brake switch	SC09	Plant Maintenance Labour
11/03/21	SC09 - park brake	SC09	Plant Maintenance Labour
12/03/21	SC09 - pos 3 assemble & c/o brake	SC09	Plant Maintenance Labour
12/03/21	SC09 - pos 3 final & tyre	SC09	Plant Maintenance Labour
12/03/21	SC09 - install pos 3 tyre	SC09	Plant Maintenance Labour
12/03/21	SC09 - pos 3 hub & tyre	SC09	Plant Maintenance Labour
15/03/21	SC09 - check over	SC09	Plant Maintenance Labour
18/03/21	SC09 - reassemble spare wheel end	SC09	Plant Maintenance Labour
07/04/21	SC09 - repairs	SC09	Plant Maintenance Labour
08/04/21	Drive SC09 from Kulwin to WRP	SC09	Plant Maintenance Plant Movement
08/04/21	SC09 - remove broken bolt in slack adjuster	SC09	Plant Maintenance Labour
08/04/21	SC09 - pos 1 bolt & repair slack adjuster	SC09	Plant Maintenance Labour
08/04/21	SC09 - install pos 1 tyre & repair GPS antenna	SC09	Plant Maintenance Labour
30/04/21	Tyre pressures	SC09	MF - Maintenance Fitter

11/05/21	Rear fan belt came off	SC09	MC - Maintenance Co-Ordinator
12/05/21	Replace front engine belts & idlers	SC09	MF - Maintenance Fitter
13/05/21	Trans hose oil leak & bowl lift cylinder	SC09	MF - Maintenance Fitter
17/05/21	Install LH bowl lift cylinder	SC09	MC - Maintenance Co-Ordinator
17/05/21	Cylinder rebuild & install	SC09	MF - Maintenance Fitter
17/05/21	c/o trans cooler hoses, rebuild LH bowl lift cylin	SC09	MF - Maintenance Fitter
18/05/21	Fabricate & install brackets for wheel chocks & cr	SC09	MF - Maintenance Fitter
18/05/21	Wash	SC09	MF - Maintenance Fitter
19/05/21	Crack repairs	SC09	MF - Maintenance Fitter
07/06/21	wash, movement checks & samples	SC09	MF - Maintenance Fitter
07/06/21	wash	SC09	MF - Maintenance Fitter
07/06/21	service	SC09	MF - Maintenance Fitter
08/06/21	repair air box	SC09	MF - Maintenance Fitter
08/06/21	Service	SC09	MF - Maintenance Fitter
09/06/21	service & defects	SC09	MF - Maintenance Fitter
09/06/21	service	SC09	MF - Maintenance Fitter
22/06/21	horn button	SC09	MC - Maintenance Co-Ordinator
23/07/21	service	SC09	MF - Maintenance Fitter
23/07/21	service	SC09	MF - Maintenance Fitter
28/07/21	flip routers	SC09	MF - Maintenance Fitter
28/07/21	flip routers	SC09	MF - Maintenance Fitter
04/08/21	Repairs	SC09	LMF - Labour Maintenance Fitter
10/08/21	replace pos 4 tyre	SC09	MC - Maintenance Co-Ordinator
10/08/21	c/o pos 4 tyre	SC09	MF - Maintenance Fitter
10/08/21	Go line checks	SC09	MF - Maintenance Fitter
19/08/21	swap over GPS screen	SC09	MC - Maintenance Co-Ordinator
23/08/21	GPS repairs	SC09	Plant Maintenance Labour
23/08/21	GPS fault	SC09	MC - Maintenance Co-Ordinator
24/08/21	install new GPS screen	SC09	MC - Maintenance Co-Ordinator
25/08/21	vibration	SC09	MF - Maintenance Fitter
02/09/21	mine radio aerial fault	SC09	MF - Maintenance Fitter
09/09/21	wash	SC09	MF - Maintenance Fitter
09/09/21	cut out wear strips	SC09	MF - Maintenance Fitter
09/09/21	service	SC09	MF - Maintenance Fitter
09/09/21	service	SC09	MF - Maintenance Fitter
10/09/21	service & GET	SC09	MF - Maintenance Fitter
10/09/21	replace wear strips & cutting edges	SC09	MF - Maintenance Fitter
10/09/21	service	SC09	MF - Maintenance Fitter
10/09/21	GET	SC09	MF - Maintenance Fitter
13/09/21	tension rear engine drive belts & lift cylinder	SC09	MF - Maintenance Fitter
13/09/21	fabricate & install front hand rail	SC09	MF - Maintenance Fitter
13/09/21	service & defects	SC09	MF - Maintenance Fitter
13/09/21	service, defects & bowl lift cylinder	SC09	MF - Maintenance Fitter
16/09/21	bail arm cylinder bearings	SC09	MF - Maintenance Fitter
16/09/21	R&R new bushes in cylinder	SC09	MF - Maintenance Fitter
22/09/21	replace bearings in apron bracket	SC09	MC - Maintenance Co-Ordinator
22/09/21	Replace bushes in lift arm bracket	SC09	MF - Maintenance Fitter
29/09/21	apron lift cylinder & defects	SC09	MF - Maintenance Fitter
29/09/21	apron cylinder & defects	SC09	MF - Maintenance Fitter
04/10/21	Bail arm repairs	SC09	Plant Maintenance Labour
04/10/21	fit bail arm & cylinder	SC09	MF - Maintenance Fitter
04/10/21	bail arm & cylinder	SC09	MF - Maintenance Fitter
13/10/21	brake assembly	SC09	Plant Maintenance Labour
13/10/21	pos 1 brake repair	SC09	MC - Maintenance Co-Ordinator
13/10/21	c/o pos 2 tyre	SC09	MF - Maintenance Fitter
13/10/21	pos 1 brake	SC09	MF - Maintenance Fitter
13/10/21	pos 2 tyre	SC09	MF - Maintenance Fitter
14/10/21	pos 1 brake & assemble & install hub	SC09	MC - Maintenance Co-Ordinator
14/10/21	pos 1 brake hub	SC09	MF - Maintenance Fitter
14/10/21	pos 1 hub	SC09	MF - Maintenance Fitter
15/10/21	GPS repairs	SC09	MC - Maintenance Co-Ordinator
15/10/21	finish off pos 1 brake	SC09	MF - Maintenance Fitter
15/10/21	adjust pos 1 brake	SC09	MF - Maintenance Fitter
25/10/21	repairs	SC09	Plant Maintenance Labour
25/10/21	remove drive shaft	SC09	MF - Maintenance Fitter
25/10/21	hydraulic leak	SC09	MF - Maintenance Fitter
26/10/21	remove power pack & split trans	SC09	MF - Maintenance Fitter

26/10/21	remove rear transmission	SC09	MC - Maintenance Co-Ordinator
26/10/21	wash, replace push pad & crack repairs	SC09	MF - Maintenance Fitter
26/10/21	remove power pack & trans	SC09	MF - Maintenance Fitter
27/10/21	reseal & remove rod & head on bowl lift cylinder	SC09	MF - Maintenance Fitter
27/10/21	parts	SC09	MC - Maintenance Co-Ordinator
27/10/21	wear strips on rhino hook & R&R pin & bushes lift	SC09	MF - Maintenance Fitter
27/10/21	reseal lift cylinder & clean up	SC09	MF - Maintenance Fitter
28/10/21	Steer cylinder reseal/removal	SC09	MF - Maintenance Fitter
28/10/21	Install & reseal Steer Cylinder	SC09	MF - Maintenance Fitter
28/10/21	Assist on Job	SC09	MC - Maintenance Co-Ordinator
28/10/21	Steer Cylinder & Bowl Lift	SC09	MF - Maintenance Fitter
29/10/21	parts	SC09	MC - Maintenance Co-Ordinator
03/11/21	trans & organise parts	SC09	MC - Maintenance Co-Ordinator
08/11/21	fab mounting bracket for engine stand	SC09	MF - Maintenance Fitter
09/11/21	demob	SC09	MC - Maintenance Co-Ordinator
09/11/21	engine stand modifications	SC09	MF - Maintenance Fitter
10/11/21	weed & seed & load float	SC09	MF - Maintenance Fitter
10/11/21	get ready to load	SC09	MC - Maintenance Co-Ordinator
10/11/21	wash	SC09	MF - Maintenance Fitter
10/11/21	engine stand mods	SC09	MF - Maintenance Fitter
06/12/21	Order parts	SC09	LMF - Labour Maintenance Fitter
07/12/21	Remove backing and clean	SC09	LMF - Labour Maintenance Fitter
08/12/21	Dissassemble Transmission	SC09	LMF - Labour Maintenance Fitter
09/12/21	Assemble Transmission	SC09	LMF - Labour Maintenance Fitter
10/12/21	Rebuild	SC09	LMF - Labour Maintenance Fitter
24/01/22	Assemble planetary packs	SC09	LMF - Labour Maintenance Fitter
25/01/22	Check over transmission	SC09	LMF - Labour Maintenance Fitter
21/02/22	Clean parts and assemble transmission	SC09	LMF - Labour Maintenance Fitter
22/02/22	Reseal transmission, PU parts	SC09	LMF - Labour Maintenance Fitter
23/02/22	Assemble Transmission	SC09	LMF - Labour Maintenance Fitter
24/02/22	Assemble transmission	SC09	LMF - Labour Maintenance Fitter
25/02/22	Assemble transmission	SC09	LMF - Labour Maintenance Fitter
25/02/22	Fit out power pack	SC09	LMF - Labour Maintenance Fitter
01/03/22	Run up rear engine	SC09	LMF - Labour Maintenance Fitter
01/03/22	Pressure Test Transmission	SC09	LMF - Labour Maintenance Fitter
07/03/22	Transmission pressure test, lube, pump, air gauge	SC09	MF - Maintenance Fitter
10/03/22	Electrical fault	SC09	MF - Maintenance Fitter
10/03/22	Electrical issues	SC09	MC - Maintenance Co-Ordinator
11/03/22	electrical fault	SC09	MF - Maintenance Fitter
11/03/22	warning issue	SC09	MC - Maintenance Co-Ordinator
15/03/22	Refit all removed panels+belly guard	SC09	MF - Maintenance Fitter
15/03/22	Electrical fault	SC09	MF - Maintenance Fitter
15/03/22	Electrical fault repair	SC09	MC - Maintenance Co-Ordinator
15/03/22	Gps	SC09	MC - Maintenance Co-Ordinator
17/03/22	Steering Hoses	SC09	MF - Maintenance Fitter
07/04/22	250hr service	SC09	MF - Maintenance Fitter
07/04/22	Service	SC09	MF - Maintenance Fitter
07/04/22	Service	SC09	MC - Maintenance Co-Ordinator
13/04/22	Rectify air leak and damage to mudguard	SC09	MF - Maintenance Fitter
13/04/22	Bogged and damaged	SC09	MC - Maintenance Co-Ordinator
14/04/22	Recover from pit	SC09	MF - Maintenance Fitter
14/04/22	Recover from pit	SC09	MF - Maintenance Fitter
19/04/22	itch Clean Up	SC09	MF - Maintenance Fitter
20/04/22	Jack up and remove P1 tyre and mud guard	SC09	MF - Maintenance Fitter
20/04/22	Wash/ remove tyre P1	SC09	MF - Maintenance Fitter
20/04/22	Remove P1 guard and support/ remove broken bolts	SC09	MF - Maintenance Fitter
21/04/22	Repair and re mount trans SOL cover	SC09	MF - Maintenance Fitter
21/04/22	Complete service/ C/O Ejector floor roller	SC09	MF - Maintenance Fitter
21/04/22	Roller	SC09	MF - Maintenance Fitter
22/04/22	Fit parts/ re fit mudguard mount ready for fitting	SC09	MF - Maintenance Fitter
22/04/22	Repair mud guard mounts	SC09	MC - Maintenance Co-Ordinator
27/04/22	C/O steer housing from under cab to hitch/ mudguard	SC09	MF - Maintenance Fitter
27/04/22	Hitch Repairs	SC09	LMF - Labour Maintenance Fitter
27/04/22	Fit P1 guard Tyre/ adjust brakes	SC09	MF - Maintenance Fitter
27/04/22	Hoses/ guards/Tyre	SC09	MC - Maintenance Co-Ordinator
28/04/22	Rebuild Servo Cylinder	SC09	LMF - Labour Maintenance Fitter
29/04/22	Clean up, inspect scraper hitch, rollers	SC09	MF - Maintenance Fitter

03/05/22	Clean Hitch Cylinder	SC09	LMF - Labour Maintenance Fitter
06/05/22	Clean up Hitch	SC09	LMF - Labour Maintenance Fitter
09/05/22	Rebuild hitch	SC09	MF - Maintenance Fitter
09/05/22	Assemble hitch	SC09	MF - Maintenance Fitter
10/05/22	Rebuild Hitch	SC09	LMF - Labour Maintenance Fitter
10/05/22	Hitch Assembly	SC09	LMF - Labour Maintenance Fitter
16/05/22	Rebuild hitch	SC09	MF - Maintenance Fitter
16/05/22	Hitch assembly	SC09	MF - Maintenance Fitter
17/05/22	Hitch assembly	SC09	MF - Maintenance Fitter
17/05/22	Hitch assembly	SC09	MF - Maintenance Fitter
26/05/22	Rebuild hitch cylinder	SC09	MF - Maintenance Fitter
26/05/22	Rebuild hitch cylinders	SC09	MF - Maintenance Fitter
26/05/22	Torque converter parts	SC09	MF - Maintenance Fitter
27/05/22	Rebuild hitch	SC09	MF - Maintenance Fitter
27/05/22	Assemble hitch, collect parts	SC09	MF - Maintenance Fitter
30/05/22	Hitch rebuild	SC09	MF - Maintenance Fitter
14/06/22	Torque Converter	SC09	MF - Maintenance Fitter
15/06/22	2000hr service	SC09	MF - Maintenance Fitter
15/06/22	2000hr service	SC09	MF - Maintenance Fitter
16/06/22	2000hr service	SC09	MF - Maintenance Fitter
16/06/22	2000hr service	SC09	MF - Maintenance Fitter
16/06/22	2000hr service	SC09	MF - Maintenance Fitter
16/06/22	Tune up rear engine	SC09	MF - Maintenance Fitter
17/06/22	2000hr service	SC09	MF - Maintenance Fitter
21/06/22	Rear torque connector.	SC09	MF - Maintenance Fitter
23/06/22	Reseal hydraulic cylinder, clean and reseal torque	SC09	MF - Maintenance Fitter
27/06/22	Tone up Front Engine, Belly Guard	SC09	LMF - Labour Maintenance Fitter
27/06/22	Tear Trans Cooler Chang Over	SC09	LMF - Labour Maintenance Fitter
27/06/22	Service & Defects	SC09	MC - Maintenance Co-Ordinator
28/06/22	Belly Guard Install Covers Run & Test	SC09	LMF - Labour Maintenance Fitter
28/06/22	Defects	SC09	LMF - Labour Maintenance Fitter
28/06/22	Service & Defects	SC09	MM - Maintenance Manager
12/07/22	Hose replacement on hitch	SC09	MF - Maintenance Fitter
12/07/22	Hydraulic hose	SC09	MC - Maintenance Co-Ordinator
21/07/22	Seat fault	SC09	MF - Maintenance Fitter
27/07/22	Repairs	SC09	MF - Maintenance Fitter
27/07/22	Oils and air leak	SC09	MF - Maintenance Fitter
28/07/22	Park brake fault	SC09	MF - Maintenance Fitter
08/08/22	Seat issues	SC09	MC - Maintenance Co-Ordinator
07/09/22	GPS	SC09	MC - Maintenance Co-Ordinator
08/09/22	GPS issue	SC09	MC - Maintenance Co-Ordinator
08/09/22	GPS Fault	SC09	MF - Maintenance Fitter
29/09/22	Torque connector assemble	SC09	MF - Maintenance Fitter
26/10/22	GPS	SC09	MF - Maintenance Fitter
28/10/22	Indicator and seat repair	SC09	MF - Maintenance Fitter
02/11/22	Flip GET/ Routers/ stinger and edges	SC09	MF - Maintenance Fitter
02/11/22	Change out quick release air valve	SC09	MF - Maintenance Fitter
02/11/22	Wash, rmove and clean flip GET and routers	SC09	MF - Maintenance Fitter
14/11/22	Defects	SC09	MF - Maintenance Fitter
30/11/22	Remove 2 way and antenna/ lead and replace	SC09	MF - Maintenance Fitter
01/12/22	Fit Acuator hose	SC09	MF - Maintenance Fitter
01/12/22	Oil levels	SC09	MF - Maintenance Fitter
07/12/22	Tyre Change out P1 and P2	SC09	MF - Maintenance Fitter
07/12/22	P1 and P2 Tyres	SC09	MF - Maintenance Fitter
08/12/22	Fire extinguisher bracket	SC09	MF - Maintenance Fitter
13/12/22	Steps	SC09	MF - Maintenance Fitter
19/12/22	Repair mine radio	SC09	MF - Maintenance Fitter
20/12/22	Pack up hitch for QLD, load onto truck	SC09	LMF - Labour Maintenance Fitter
04/01/23	Hitch components	SC09	MF - Maintenance Fitter
09/01/23	Take hitch to heywood	SC09	MF - Maintenance Fitter
13/01/23	250hr service	SC09	MF - Maintenance Fitter
16/01/23	Deects heater taps, change out seat, check fluid	SC09	MF - Maintenance Fitter
16/01/23	Complete service/ C/O seat	SC09	MF - Maintenance Fitter
19/01/23	Change out rear eng drive belts	SC09	MF - Maintenance Fitter
24/01/23	Mud guard repairs	SC09	MF - Maintenance Fitter
24/01/23	P1 Guard repair	SC09	MF - Maintenance Fitter
25/01/23	Repair mud guard	SC09	MF - Maintenance Fitter

25/01/23	Guard repair	SC09	MF - Maintenance Fitter
25/01/23	GET	SC09	MF - Maintenance Fitter
31/01/23	Broken Guards	SC09	MF - Maintenance Fitter
02/02/23	Dismantle hitch	SC09	MF - Maintenance Fitter
02/02/23	Wash hitch and trans set up machine/ drain fluids	SC09	MF - Maintenance Fitter
02/02/23	Remove bail arm, disassemble tractor/scraper	SC09	MF - Maintenance Fitter
02/02/23	remove and disassemble hitch	SC09	MF - Maintenance Fitter
02/02/23	Split machine	SC09	MF - Maintenance Fitter
02/02/23	Wash	SC09	MF - Maintenance Fitter
03/02/23	C/O Hitch removal	SC09	MF - Maintenance Fitter
03/02/23	Hitch removal C/O trans	SC09	MF - Maintenance Fitter
03/02/23	C/O hitch	SC09	MF - Maintenance Fitter
06/02/23	Guard removal	SC09	MF - Maintenance Fitter
06/02/23	Prep hitch remove bush's	SC09	MF - Maintenance Fitter
06/02/23	Hitch repair	SC09	MF - Maintenance Fitter
07/02/23	C/O hitch repairs	SC09	MF - Maintenance Fitter
07/02/23	Hitch cylinder repair	SC09	MF - Maintenance Fitter
08/02/23	Fabrication L/H mudguard	SC09	MF - Maintenance Fitter
08/02/23	Prep and fit pump drive and hosing, prep hitch	SC09	MF - Maintenance Fitter
08/02/23	Refit Gear drive to rear of trans	SC09	MF - Maintenance Fitter
09/02/23	Hitch/ new hose installation	SC09	MF - Maintenance Fitter
09/02/23	Remove old and replace new hitch	SC09	MF - Maintenance Fitter
09/02/23	Hitch repairs	SC09	MF - Maintenance Fitter
09/02/23	Hitch repairs	SC09	MF - Maintenance Fitter
10/02/23	Hitch installation	SC09	MF - Maintenance Fitter
10/02/23	Prep and fit hitch	SC09	MF - Maintenance Fitter
10/02/23	Hitch install	SC09	MF - Maintenance Fitter
10/02/23	SC09 spotter	SC09	MF - Maintenance Fitter
22/02/23	Assemble hitch	SC09	MF - Maintenance Fitter
22/02/23	Prep hitch/ scraper to be joined	SC09	MF - Maintenance Fitter
22/02/23	Join tractor and scraper	SC09	MF - Maintenance Fitter
22/02/23	Prep for joining machine	SC09	MF - Maintenance Fitter
22/02/23	Join tractor to scraper	SC09	MF - Maintenance Fitter
23/02/23	Continue putting machine back together	SC09	MF - Maintenance Fitter
23/02/23	Hitch	SC09	MF - Maintenance Fitter
23/02/23	Trnsion hitch pins, graese lines C/O	SC09	MF - Maintenance Fitter
23/02/23	hitch repairs	SC09	MF - Maintenance Fitter
24/02/23	Hitch repairs	SC09	MF - Maintenance Fitter
24/02/23	Hitch repairs	SC09	MF - Maintenance Fitter
27/02/23	Jack up, remove POS1 hose under hitch tec	SC09	LMF - Labour Maintenance Fitter
27/02/23	Hitch repairs	SC09	MF - Maintenance Fitter
28/02/23	C/O wiper stalk	SC09	MF - Maintenance Fitter
28/02/23	Fit new hoses	SC09	MF - Maintenance Fitter
28/02/23	Rear trans C/O	SC09	MF - Maintenance Fitter
01/03/23	Remove Wheelend and drill holes in Mudguard	SC09	MF - Maintenance Fitter
01/03/23	Remove P1 axle drain/ drain oils remove wheel end	SC09	MF - Maintenance Fitter
01/03/23	Hub repair	SC09	MF - Maintenance Fitter
02/03/23	Paint guard	SC09	MF - Maintenance Fitter
02/03/23	Install final drive	SC09	MF - Maintenance Fitter
02/03/23	Install mudguard POS 1	SC09	MF - Maintenance Fitter
02/03/23	Fit tyre POS 1	SC09	MF - Maintenance Fitter
02/03/23	Fit threads to diff housing/ studs/ fit bracket	SC09	MF - Maintenance Fitter
02/03/23	Wheel ends/ tension/ fit axle brake booster grease	SC09	MF - Maintenance Fitter
02/03/23	Fit mud guard/ back and fit grease pod	SC09	MF - Maintenance Fitter
02/03/23	Fit tread inserts to diff housing	SC09	MF - Maintenance Fitter
02/03/23	Fit wheel end, tension bolts	SC09	MF - Maintenance Fitter
06/03/23	Top up Hyd oil/ trans and diff	SC09	MF - Maintenance Fitter
07/03/23	Fill diff/ ourge grease sys and fill oils run up-	SC09	MF - Maintenance Fitter
07/03/23	Shim Hitch- rear horizontal pin/ adjust tyre	SC09	MF - Maintenance Fitter
07/03/23	Purge grease system	SC09	MF - Maintenance Fitter
07/03/23	Finish hitch repairs/ wiring/hoses	SC09	MF - Maintenance Fitter
07/03/23	Complete hitch install- bleed steering/ adjust bra	SC09	MF - Maintenance Fitter
08/03/23	Mud flaps	SC09	MF - Maintenance Fitter
08/03/23	Fill P1 oil and top up trans	SC09	MF - Maintenance Fitter
08/03/23	Rectify brakes- not releasing	SC09	MF - Maintenance Fitter
29/03/23	C/O park brake solenoid	SC09	MF - Maintenance Fitter
15/05/23	Jump start rear engine	SC09	LMF - Labour Maintenance Fitter

23/05/23	Check and adjust hitch pressures	SC09	MF - Maintenance Fitter
23/05/23	Fit external radio speaker	SC09	MF - Maintenance Fitter
24/05/23	500hr service	SC09	MF - Maintenance Fitter
24/05/23	500hr Service	SC09	MF - Maintenance Fitter
24/05/23	Service	SC09	MF - Maintenance Fitter
05/06/23	Check ove, jump start rear engine	SC09	MF - Maintenance Fitter
05/07/23	Isolator maintenance, remove battery and assembly	SC09	MF - Maintenance Fitter
06/07/23	Remove/ install isolator- ignition	SC09	MF - Maintenance Fitter
13/07/23	Install isolator and batteries	SC09	MF - Maintenance Fitter
17/08/23	Replace batteries rear engine	SC09	MF - Maintenance Fitter
02/10/23	Electrical fault	SC09	MF - Maintenance Fitter
03/10/23	Joystick elec fault- replace stack	SC09	MF - Maintenance Fitter
04/10/23	Engine light and check dash cam	SC09	MF - Maintenance Fitter
09/10/23	replace Ac blower	SC09	MF - Maintenance Fitter
10/10/23	Hydraulic Fault	SC09	MF - Maintenance Fitter
11/10/23	Steering Fault	SC09	MF - Maintenance Fitter
12/10/23	Joystick fault	SC09	MF - Maintenance Fitter
12/10/23	AC service	SC09	MF - Maintenance Fitter
13/10/23	Joystick change out	SC09	MF - Maintenance Fitter
17/10/23	Steering fault	SC09	MF - Maintenance Fitter
18/10/23	Replace trans speed sensors	SC09	MF - Maintenance Fitter
18/10/23	Inspect steering fault	SC09	MF - Maintenance Fitter
23/10/23	Replace retarder valve and diff lock valve	SC09	MF - Maintenance Fitter
26/10/23	Repair bowl lift cylinder retainer/ free up pin	SC09	MF - Maintenance Fitter
27/10/23	Replace GET	SC09	MF - Maintenance Fitter
30/10/23	Fabricate plates/ decals	SC09	MF - Maintenance Fitter
03/11/23	Plant Cert form	SC09	MF - Maintenance Fitter
17/11/23	Hyd hose	SC09	MF - Maintenance Fitter
20/11/23	Hyd Hose- Steer hose	SC09	MF - Maintenance Fitter
22/11/23	250hr service	SC09	MF - Maintenance Fitter
22/11/23	Tyres	SC09	MF - Maintenance Fitter
22/11/23	250hr service	SC09	MF - Maintenance Fitter
22/11/23	Change Pos 1 and 2 tyres	SC09	MF - Maintenance Fitter
23/11/23	Pos 3 and 4 tyres	SC09	MF - Maintenance Fitter
23/11/23	POS 3 and 4 tyre change	SC09	MF - Maintenance Fitter
23/11/23	Rear decal fabrication and installation	SC09	MF - Maintenance Fitter
27/11/23	Rear engine, install alternator, belts, etc	SC09	MF - Maintenance Fitter
01/12/23	Defects, C/O fuel pressure regulator rear engine	SC09	MF - Maintenance Fitter
06/12/23	Recover scraper Pit 23	SC09	MF - Maintenance Fitter
07/12/23	trans fault, remove trans screens- inspect	SC09	MF - Maintenance Fitter
07/12/23	Fault code	SC09	MF - Maintenance Fitter
08/12/23	Drain trans, pull screens+ filter- metal in filter	SC09	MF - Maintenance Fitter
14/12/23	transmission Fault	SC09	MC - Maintenance Co-Ordinator
14/12/23	Wash	SC09	MC - Maintenance Co-Ordinator
14/12/23	Trans Fault	SC09	MF - Maintenance Fitter
14/12/23	Pats List	SC09	MF - Maintenance Fitter
15/12/23	Wash and move	SC09	MC - Maintenance Co-Ordinator
15/12/23	Order parts SC09 fron trans	SC09	MF - Maintenance Fitter
18/12/23	Drain Hyd, trans, diff and evac	SC09	MF - Maintenance Fitter
18/12/23	Remove hitch pump, hyd pumps, drive shaft etc	SC09	MF - Maintenance Fitter
18/12/23	Remove trans, wash, load, seal diff housing	SC09	MF - Maintenance Fitter
18/12/23	Remove Transmission	SC09	MF - Maintenance Fitter
18/12/23	Remove Transmission	SC09	MF - Maintenance Fitter
19/12/23	Disassemble transmission	SC09	MF - Maintenance Fitter
20/12/23	Disassemble, clean and inspect	SC09	MF - Maintenance Fitter
20/12/23	Collect parts/ clean inspect torque converter	SC09	MF - Maintenance Fitter
20/12/23	Clean/ inspect parts, planterys- part lists	SC09	MF - Maintenance Fitter
21/12/23	Clean and inspect, replace hoses, drop at WA	SC09	MF - Maintenance Fitter
21/12/23	Disassemble control valve, rotary sensor valve	SC09	MF - Maintenance Fitter
21/12/23	Parts list, grease up second hand parts, clean par	SC09	MF - Maintenance Fitter
04/01/24	Clean and buff hoses, collect parts from William A	SC09	MF - Maintenance Fitter
04/01/24	Clean gears, assemble transfer gear, sort parts	SC09	MF - Maintenance Fitter
05/01/24	Clean parts, collect parts from WA, drop off hose	SC09	MF - Maintenance Fitter
05/01/24	Clean hoses, shafts for assembly	SC09	MF - Maintenance Fitter
05/01/24	Clean torque con parts for assembly, buff and clea	SC09	MF - Maintenance Fitter
08/01/24	Assemble fron transmission	SC09	MF - Maintenance Fitter
09/01/24	Clean parts, assemble transmission	SC09	MF - Maintenance Fitter

10/01/24	Assemble Transmission	SC09	MF - Maintenance Fitter
11/01/24	Assemble transmission	SC09	MF - Maintenance Fitter
22/01/24	Assemble Transmission	SC09	MF - Maintenance Fitter
23/01/24	Assemble Transmission	SC09	MF - Maintenance Fitter
24/01/24	Assemble transmission	SC09	MF - Maintenance Fitter
25/01/24	Assemble/ prepare for and take to transport compan	SC09	MF - Maintenance Fitter
29/01/24	Remove belly guard- transmission	SC09	MF - Maintenance Fitter
30/01/24	Clean out diff housing, transmission clean etc	SC09	MF - Maintenance Fitter
05/02/24	Assist with trans fitment, paperwork	SC09	MC - Maintenance Co-Ordinator
05/02/24	Load transmission and travel to Douglas	SC09	MF - Maintenance Fitter
05/02/24	Buff, clean Diff housing, install o rings	SC09	MF - Maintenance Fitter
05/02/24	JHA's install transmission	SC09	MF - Maintenance Fitter
06/02/24	Install pumps suction lines	SC09	MF - Maintenance Fitter
06/02/24	Install hyd lines	SC09	MF - Maintenance Fitter
06/02/24	Filter base hyd lines, connect ET- run and test	SC09	MF - Maintenance Fitter
06/02/24	Transmission installation	SC09	MF - Maintenance Fitter
06/02/24	Levels in SC09	SC09	MF - Maintenance Fitter
07/02/24	Drive Fault	SC09	MC - Maintenance Co-Ordinator
07/02/24	Test Machine, Troubleshoot vibration, check retarder	SC09	MF - Maintenance Fitter
08/02/24	Assist with retarder removal/ wash load parts	SC09	MC - Maintenance Co-Ordinator
08/02/24	Faults- Slip clutch failed	SC09	MF - Maintenance Fitter
09/02/24	Dissassemble retarder housing, clean	SC09	MF - Maintenance Fitter
12/02/24	Rear main seal	SC09	MF - Maintenance Fitter
13/02/24	Clean housing and crank shaft	SC09	MF - Maintenance Fitter
13/02/24	Install main seal, fly wheel etc	SC09	MF - Maintenance Fitter
13/02/24	Assist with flywheel install	SC09	MF - Maintenance Fitter
14/02/24	Clean parts disassemble, assemble, new bearings	SC09	MF - Maintenance Fitter
15/02/24	Load parts/ wrap and seal	SC09	MF - Maintenance Fitter
15/02/24	Assemble retarder	SC09	MF - Maintenance Fitter
15/02/24	Install retarder, housing etc	SC09	MF - Maintenance Fitter
15/02/24	Assist with fitting retarder	SC09	MF - Maintenance Fitter
16/02/24	Slip clutch hose	SC09	MF - Maintenance Fitter
16/02/24	Top up oils, test, install belly guard	SC09	MF - Maintenance Fitter
21/02/24	Engine fault	SC09	MC - Maintenance Co-Ordinator
22/02/24	Engine fault	SC09	MC - Maintenance Co-Ordinator
27/02/24	Replace dust ejector hose and pit 10 fuel run	SC09	MC - Maintenance Co-Ordinator
05/03/24	Refit Apron lift arm onto trunnion	SC09	MC - Maintenance Co-Ordinator
08/03/24	Rebuild hitch cyclinder	SC09	MF - Maintenance Fitter
20/03/24	Rear engine belts	SC09	MF - Maintenance Fitter
20/03/24	Rear engine belts	SC09	MF - Maintenance Fitter
05/04/24	1000hr service	SC09	MF - Maintenance Fitter
05/04/24	1000hr service	SC09	MC - Maintenance Co-Ordinator
10/04/24	Replace Trunions and hyd hose	SC09	MF - Maintenance Fitter
10/04/24	Replace apron trunnions, caps, 2x hyd hoses	SC09	MF - Maintenance Fitter
15/04/24	Replace blown hose	SC09	MC - Maintenance Co-Ordinator
29/04/24	Replace GPS cradle	SC09	MC - Maintenance Co-Ordinator
14/06/24	250hr service	SC09	MF - Maintenance Fitter
14/06/24	service	SC09	MF - Maintenance Fitter
19/06/24	Replace radio hand piece	SC09	MF - Maintenance Fitter
24/06/24	Filter restriction fault	SC09	MF - Maintenance Fitter
25/06/24	Replace GET2.5	SC09	MF - Maintenance Fitter
25/06/24	Fit scraper chassis harness	SC09	MF - Maintenance Fitter
02/07/24	Change rear alternator belt and pulley @ Pit	SC09	MF - Maintenance Fitter
09/07/24	Engine light - Front air filter	SC09	MF - Maintenance Fitter
24/07/24	Inspect machine/ order parts	SC09	MF - Maintenance Fitter
24/07/24	Move to wash bay and wash	SC09	MF - Maintenance Fitter
25/07/24	Fix GPS not powering up	SC09	MF - Maintenance Fitter
25/07/24	Inspect for defects/ remove hydraulic hose above h	SC09	MF - Maintenance Fitter
25/07/24	Replace hyd hose, order parts, replace mud flap,	SC09	MF - Maintenance Fitter
29/07/24	Front engine exhaust manifold re seal	SC09	MF - Maintenance Fitter
30/07/24	Exhaust manifold re seal, rocker covers re seal	SC09	MF - Maintenance Fitter
31/07/24	exhaust manifold re seal	SC09	MF - Maintenance Fitter
01/08/24	Finish exhaust manifold	SC09	MF - Maintenance Fitter
12/08/24	Seat repairs	SC09	MC - Maintenance Co-Ordinator
12/08/24	Seat repairs	SC09	MF - Maintenance Fitter
13/08/24	Turbo drain hose, Repair wiring harness	SC09	MC - Maintenance Co-Ordinator
14/08/24	Fit new boost hose and test	SC09	MF - Maintenance Fitter

19/09/24	Breakdown in pit, damage to guard and trans line	SC09	MF - Maintenance Fitter
20/09/24	Recover Scraper, Power trin lines	SC09	MF - Maintenance Fitter
20/09/24	Defects in pit	SC09	MF - Maintenance Fitter
23/09/24	Hydraulic hoses and defects	SC09	MF - Maintenance Fitter
23/09/24	Recover machine from Pit	SC09	MF - Maintenance Fitter
23/09/24	Fit temp hoses and recover from Pit23	SC09	MF - Maintenance Fitter
24/09/24	R&R isolate	SC09	MF - Maintenance Fitter
25/09/24	Tyre removal	SC09	MF - Maintenance Fitter
25/09/24	Was PS1, move into workshop and jack up	SC09	MF - Maintenance Fitter
26/09/24	Remove tyreStraighten guard bracket	SC09	MF - Maintenance Fitter
26/09/24	Remove tyre P1, order parts, check trans	SC09	MF - Maintenance Fitter
30/09/24	Hyd lines, power train hoses	SC09	MF - Maintenance Fitter
30/09/24	Remove broken trans lines	SC09	MF - Maintenance Fitter
01/10/24	Assemble machine, install pipe trans	SC09	MF - Maintenance Fitter
01/10/24	Fit new pipes, inner guard, finish repairs	SC09	MF - Maintenance Fitter
02/10/24	Collect parts from WA Hsm	SC09	MF - Maintenance Fitter
07/10/24	Brake defect	SC09	MF - Maintenance Fitter
08/10/24	Remove muffler, pre cleaner, c/o run up test	SC09	MF - Maintenance Fitter
08/10/24	Replace muffler and pre cleaner	SC09	MF - Maintenance Fitter
10/10/24	Straighten POS1 guard	SC09	MF - Maintenance Fitter
14/10/24	Repalce leaking trans hose	SC09	MF - Maintenance Fitter
17/10/24	Seat base, Draft arm pinions, order parts	SC09	MF - Maintenance Fitter
17/10/24	Defect repairs, tidy workshop	SC09	MF - Maintenance Fitter
18/10/24	Replace leaking trans hose, front engine, throttle	SC09	MF - Maintenance Fitter
21/10/24	defects	SC09	MF - Maintenance Fitter
21/10/24	Chase up belly guards, inspect- bent guards	SC09	MF - Maintenance Fitter
21/10/24	make new trans hoses and fit	SC09	MF - Maintenance Fitter
22/10/24	straighten belly plate and fit	SC09	MF - Maintenance Fitter
22/10/24	RHS steering cylinder	SC09	MF - Maintenance Fitter
22/10/24	Drill out broken rear belly plate bolts, re thread	SC09	MF - Maintenance Fitter
23/10/24	Bowl trunions, cpas instal new bolts, torque to sp	SC09	MF - Maintenance Fitter
23/10/24	Repair seat, finish fitting steer cylinder	SC09	MF - Maintenance Fitter
23/10/24	Replace side arm trunions and caps, clean up	SC09	MF - Maintenance Fitter
24/10/24	Install belly guard, steer cylinder pin- return	SC09	MF - Maintenance Fitter
24/10/24	Belly plate installation	SC09	MF - Maintenance Fitter
01/11/24	Engine light	SC09	MF - Maintenance Fitter
06/11/24	500hr service	SC09	MF - Maintenance Fitter
06/11/24	500hr service	SC09	MF - Maintenance Fitter
06/11/24	500hr service	SC09	MF - Maintenance Fitter
11/11/24	Change out rear engine pedal	SC09	MF - Maintenance Fitter
12/11/24	Inspect diff lock operation	SC09	MF - Maintenance Fitter
12/11/24	Diff lock	SC09	MF - Maintenance Fitter
13/11/24	cert forms	SC09	MF - Maintenance Fitter
15/11/24	Check injector noise test	SC09	MF - Maintenance Fitter
19/11/24	Inspect seat	SC09	MF - Maintenance Fitter
20/11/24	Femove seat from machine/ disassemble	SC09	MF - Maintenance Fitter
20/11/24	Seat repairs	SC09	MF - Maintenance Fitter
21/11/24	Install seat return to work	SC09	MF - Maintenance Fitter
21/11/24	Over heating rear engine	SC09	MF - Maintenance Fitter
22/11/24	Wash out radiators front and rear, check over	SC09	MF - Maintenance Fitter
03/12/24	Troubleshoot diff lock fault, order parts	SC09	MF - Maintenance Fitter
04/12/24	Inspect, maintain air leaks, rear engine belts	SC09	MF - Maintenance Fitter
04/12/24	Diff lock fault and air leak	SC09	MF - Maintenance Fitter
13/12/24	Inspect diff lock, c/o switch soleinoid, defects	SC09	MF - Maintenance Fitter
19/12/24	Clean out Radiators, filters	SC09	MF - Maintenance Fitter
10/01/25	Remove Apron pin	SC09	MF - Maintenance Fitter
10/01/25	Install apron pin	SC09	MF - Maintenance Fitter
10/01/25	Replace apron pivot- apron arm pin	SC09	MF - Maintenance Fitter
15/01/25	Clean out radiators, eplace air cleaners, inspect	SC09	MF - Maintenance Fitter
15/01/25	Wash radiators/ change filters	SC09	MF - Maintenance Fitter
17/01/25	Perform 250 hr service	SC09	MF - Maintenance Fitter
17/01/25	250hr service	SC09	MF - Maintenance Fitter
22/01/25	Fabrication on body	SC09	MF - Maintenance Fitter
29/01/25	removed and replaced blown hose	SC09	MF - Maintenance Fitter
31/01/25	Cutting edges- order parts	SC09	MF - Maintenance Fitter
31/01/25	GET inspection	SC09	MF - Maintenance Fitter
31/01/25	GET C/O	SC09	MF - Maintenance Fitter

04/02/25	Clean Radiators	SC09	MF - Maintenance Fitter
10/02/25	Lift cylinder, pin retainer, rear belts	SC09	MF - Maintenance Fitter
10/02/25	Replace rear engine bolts	SC09	MF - Maintenance Fitter
10/02/25	Radio dropping out	SC09	MF - Maintenance Fitter
11/02/25	Apron cracks	SC09	MF - Maintenance Fitter
12/02/25	Defects, apron	SC09	MF - Maintenance Fitter
12/02/25	Apron defects/ wash	SC09	MF - Maintenance Fitter
13/02/25	Apron repairs, return to work	SC09	MF - Maintenance Fitter
26/02/25	Blown hose	SC09	MF - Maintenance Fitter
28/02/25	Defects, adjust brakes, air cleaner	SC09	MF - Maintenance Fitter
28/02/25	Defects	SC09	MF - Maintenance Fitter
03/03/25	Wash rear engine/ radiator	SC09	MF - Maintenance Fitter
12/03/25	Perform 2000hr service	SC09	MF - Maintenance Fitter
12/03/25	Start 2000hr service	SC09	MF - Maintenance Fitter
13/03/25	Return to work, run up and test	SC09	MF - Maintenance Fitter
13/03/25	Hydraulic oil leaks, lift cylinder	SC09	MF - Maintenance Fitter
14/03/25	Perform 2000hr service	SC09	MF - Maintenance Fitter
14/03/25	Service	SC09	MF - Maintenance Fitter
17/03/25	Check GPS	SC09	MF - Maintenance Fitter
17/03/25	Checkover	SC09	MF - Maintenance Fitter
20/03/25	Engine fault- replace air filter	SC09	MF - Maintenance Fitter
25/03/25	Air con fault	SC09	MF - Maintenance Fitter
31/03/25	GPS fault	SC09	MF - Maintenance Fitter
31/03/25	Troubleshoot GPS fault	SC09	MF - Maintenance Fitter
01/04/25	Troubleshoot/ repair GPS	SC09	MF - Maintenance Fitter
02/04/25	Weld guard/ install guard	SC09	MF - Maintenance Fitter
02/04/25	P1 guard repairs	SC09	MF - Maintenance Fitter
08/04/25	GPS fault	SC09	MF - Maintenance Fitter
08/04/25	Check GPS	SC09	MF - Maintenance Fitter
09/04/25	Repair GPS	SC09	MF - Maintenance Fitter
16/04/25	Hydraulic line repairs	SC09	MF - Maintenance Fitter
16/04/25	Replace ejector roller	SC09	MF - Maintenance Fitter
17/04/25	Troubleshoot code, changeout air cleaners	SC09	MF - Maintenance Fitter
17/04/25	AC repairs	SC09	MF - Maintenance Fitter
29/04/25	Troubleshoot engine fault	SC09	MF - Maintenance Fitter
29/04/25	Change out dust ejector tube, check during break	SC09	MF - Maintenance Fitter
01/05/25	Adjust Brakes	SC09	MF - Maintenance Fitter
01/05/25	P1 brake booster, adjust brakes	SC09	MF - Maintenance Fitter
01/05/25	Replace P4 booster adjust brakes	SC09	MF - Maintenance Fitter
02/05/25	Inspect fault code- replace sensor	SC09	MF - Maintenance Fitter
05/05/25	Clean out Radiator	SC09	MF - Maintenance Fitter
05/05/25	Breakdown E-stop fault, in pit	SC09	MF - Maintenance Fitter
06/05/25	Perform 250hr service	SC09	MF - Maintenance Fitter
06/05/25	250hr service	SC09	MF - Maintenance Fitter
06/05/25	Replace seat	SC09	MF - Maintenance Fitter
07/05/25	Clean out radiators and air cleaners	SC09	MF - Maintenance Fitter
09/05/25	Pos 2 Guard repairs	SC09	MF - Maintenance Fitter
12/05/25	Air filters	SC09	MF - Maintenance Fitter
14/05/25	Clean out radiators and air filters	SC09	MF - Maintenance Fitter
15/05/25	Inspect scrapers, defects	SC09	MF - Maintenance Fitter
15/05/25	Replace grease lines	SC09	MF - Maintenance Fitter
16/05/25	Clean out rear radiator	SC09	MF - Maintenance Fitter
19/05/25	Air leak- diff lock switch faulty	SC09	MF - Maintenance Fitter
27/05/25	Air cleaners, check over machine	SC09	MF - Maintenance Fitter
29/05/25	Derate fault	SC09	MF - Maintenance Fitter
30/05/25	GPS fault	SC09	MF - Maintenance Fitter
02/06/25	Fault codes- blocked air filter, replaced tail pip	SC09	MF - Maintenance Fitter
05/06/25	oil leak fault	SC09	MF - Maintenance Fitter
06/06/25	Change out G.E.T	SC09	MF - Maintenance Fitter
06/06/25	G.E.T Stinger	SC09	MF - Maintenance Fitter
06/06/25	Defect list	SC09	MF - Maintenance Fitter
10/06/25	Machine defects	SC09	MF - Maintenance Fitter
10/06/25	Defects/ diff oil/ rollers	SC09	MF - Maintenance Fitter
11/06/25	Defects/ belt replacement/ pre cleaner replacement	SC09	MF - Maintenance Fitter
12/06/25	Machine defects. Rollers	SC09	MF - Maintenance Fitter
12/06/25	Repair signage SME repair bracket	SC09	MF - Maintenance Fitter
18/06/25	Product link fault	SC09	MF - Maintenance Fitter

24/06/25	Electrical fault, change cab mounts	SC09	MF - Maintenance Fitter
24/06/25	Cab mounts- elec fault, vision link fault	SC09	MF - Maintenance Fitter
14/07/25	Electrical fault	SC09	MF - Maintenance Fitter
15/07/25	Data link fault	SC09	MF - Maintenance Fitter
16/07/25	Machine Defects	SC09	MC - Maintenance Co-Ordinator
16/07/25	Machine defects	SC09	MF - Maintenance Fitter
29/07/25	Remove POS 1 and JHA	SC09	MF - Maintenance Fitter
29/07/25	Remove hitch harness	SC09	MF - Maintenance Fitter
30/07/25	Hitch Harness	SC09	MF - Maintenance Fitter
30/07/25	Install POS 1 and JHA CCM	SC09	MF - Maintenance Fitter
30/07/25	Replace hitch harness, Fit P1 tyre	SC09	MF - Maintenance Fitter
07/08/25	Trans oil and Pos 4 wheel end oil levels	SC09	MF - Maintenance Fitter
13/08/25	Washed to do duo cone seals	SC09	MF - Maintenance Fitter
14/08/25	Remove POS 4 tyre	SC09	MF - Maintenance Fitter
14/08/25	final drive	SC09	MF - Maintenance Fitter
14/08/25	Remove wheel spindal, Duo cone seal, clean parts	SC09	MF - Maintenance Fitter
14/08/25	Assemble wheel end and final drive, Install tyre	SC09	MF - Maintenance Fitter
14/08/25	Duo cone seal stripped POS 4 final drive	SC09	MF - Maintenance Fitter
14/08/25	Clean components to re assemble	SC09	MF - Maintenance Fitter
14/08/25	Re assemble filled oil tested- ok	SC09	MF - Maintenance Fitter
19/08/25	Electrical Fault	SC09	MF - Maintenance Fitter
20/08/25	Remove GPS screen to fit to SC18	SC09	MF - Maintenance Fitter
22/08/25	Insepect rollers	SC09	MF - Maintenance Fitter
25/08/25	Inspected rollers/ ordered parts	SC09	MF - Maintenance Fitter
26/08/25	Perform 500hr service	SC09	MF - Maintenance Fitter
26/08/25	Service	SC09	MF - Maintenance Fitter
26/08/25	Roller change out	SC09	MF - Maintenance Fitter
27/08/25	Machine defects- Samples	SC09	MF - Maintenance Fitter
27/08/25	Finish off sampling oils, replace wiper blades	SC09	MF - Maintenance Fitter
04/09/25	Machine defects, check over belts, pulley, check	SC09	MF - Maintenance Fitter
15/09/25	Troubleshoot fuel pressure fault	SC09	MF - Maintenance Fitter
15/09/25	Electrical fault	SC09	MF - Maintenance Fitter
16/09/25	Diagnose fault codes	SC09	MF - Maintenance Fitter
22/09/25	Fit Step	SC09	MF - Maintenance Fitter
30/09/25	Checkover, fault codes, hyd breather	SC09	MF - Maintenance Fitter
03/10/25	Check over, C/O Hyd/ trans breather	SC09	MF - Maintenance Fitter
08/10/25	Hydraulic oil leaks	SC09	MF - Maintenance Fitter
08/10/25	Oil leak	SC09	MF - Maintenance Fitter
10/10/25	Change out rear engine fuel pressure sensor	SC09	MF - Maintenance Fitter
10/10/25	Grease fault	SC09	MF - Maintenance Fitter
13/10/25	Grease line repairs/ test	SC09	MF - Maintenance Fitter
14/10/25	grease live fitting	SC09	MF - Maintenance Fitter
16/10/25	Replace ejector floor roller	SC09	MF - Maintenance Fitter
22/10/25	Wash machine for repairs	SC09	MF - Maintenance Fitter
22/10/25	Check over, remove belly plates, oil leaks	SC09	MF - Maintenance Fitter
23/10/25	Repair front transmission oil leak	SC09	MF - Maintenance Fitter
23/10/25	replace rear engine belts and tensioner/ trans oil	SC09	MF - Maintenance Fitter
27/10/25	Change out cooler retarder lines	SC09	MF - Maintenance Fitter
27/10/25	Door Repairs fabrication/ Bonnet Fabrication	SC09	MF - Maintenance Fitter
27/10/25	Install belly guard/ fit door	SC09	MF - Maintenance Fitter
07/11/25	Prep machine for service, organise filters, parts	SC09	MF - Maintenance Fitter
10/11/25	Perform 250hr service	SC09	MF - Maintenance Fitter
10/11/25	G.E.T c/o	SC09	MF - Maintenance Fitter
10/11/25	250hr service	SC09	MF - Maintenance Fitter
10/11/25	250 hr service	SC09	MF - Maintenance Fitter
18/11/25	Cert form check over	SC09	MF - Maintenance Fitter
21/11/25	Machne defects. Hydraulic oil leaks	SC09	MF - Maintenance Fitter
21/11/25	Inspection/ clean ari cleaners	SC09	MF - Maintenance Fitter
24/11/25	Cert form- check over	SC09	MF - Maintenance Fitter
26/11/25	G.E.T inspection	SC09	MF - Maintenance Fitter
26/11/25	GET/ machine inspection	SC09	MF - Maintenance Fitter
01/12/25	Machine defects/ troubleshoot elec fault	SC09	MF - Maintenance Fitter
01/12/25	Wiring fault	SC09	MF - Maintenance Fitter
02/12/25	Troubleshoot data link fault	SC09	MF - Maintenance Fitter
02/12/25	Elecrtical fault	SC09	MF - Maintenance Fitter
03/12/25	Product link fault	SC09	MF - Maintenance Fitter
03/12/25	Air fault- Troubleshoot	SC09	MF - Maintenance Fitter

03/12/25	Diagnose electrical fault- tested (ok)	SC09	MF - Maintenance Fitter
03/12/25	Diagnose and repaired air leak	SC09	MF - Maintenance Fitter
09/12/25	GPS fault	SC09	MF - Maintenance Fitter
11/12/25	Air con switch	SC09	MF - Maintenance Fitter
12/12/25	Start fault	SC09	MF - Maintenance Fitter
15/12/25	Clean out radiator	SC09	MF - Maintenance Fitter
	SC09- Start fault		
	SC09- Replace battery		
	SC09- Starter Motor		
	SC09- Clean out radiators		
	SC09- Change out Batteries		
	SC09- Air con fan speed switch		
	SC09- Change oil front and rear, front diff lock		
	SC09- G.E.T/ Rotate Stinger		
	SC09 CAT 627G Scraper - Service Schedule Step 1000 (308)		
	SC09- fault codes/ repair guards POS 1 and 2		
	SC09 CAT 627G Scraper - Service Schedule Step 1250 (459)		
	SC09- Inspect and maintain radio		
	SC09- Wipers		
	SC09- Inspect and maintain air con		
	SC09- inspect and maintain clutch		
	SC09- change out ejector roller		
	SC09- Fuel hose inspect and maintain		
	SC09- Radio bracket fabricate and install		
	SC09- Wash and demobe ready for off site		

3609

Accident Prevention
 Read and understand safety warning in the operation and maintenance manual
 Have you completed a take 2?
 Have your job circumstances change since completing your take 2?

627 Scraper 250 Hour Service Sheet

Date:	10/11/25	Name:	Diont PJ Dave
Service Type:	250 Hour	Tractor Serial No.	DBD00838
Machine Hours:	18,751 HRS.	Trailer Serial No.	DBZ00838
<input checked="" type="checkbox"/>	Machine has been cleaned prior to commencement of service?		
<input checked="" type="checkbox"/>	Machine has been positioned on flat level ground		
<input checked="" type="checkbox"/>	All implements have been lowered		
<input checked="" type="checkbox"/>	Machine has been isolated and locked out		

Tractor

Compartment	Oil Type	Amounts (Litres)
Engine	15W-40	38 Litres
Filter List	Qty	Part Number
Engine Oil Filter	1	1R-1808
Primary Air Filter	1	6I-2507
Fuel Filter	1	1R-0762
Fuel Water Separator	1	326-1643
Cab Air Filter	1	268-6704
Cab Air Filter	1	259-3222
Scheduled Oil Sample	2	SOS003

Trailer

Compartment	Oil Type	Amount (Litres)
Engine	15W-40	30 Litres
Filter List	Qty	Part Number
Engine Oil Filter	1	1R-1808
Primary Air Filter	1	6I-0274
Fuel Filter	1	1R-0762
Fuel Water Separator	1	326-1644
Scheduled Oil Sample	2	SOS003

Note: The electronic copy of this document is controlled. To ensure that other copies of this document are current, check the revision number and date against the compliance management database, Qudos

Prepared By: Troy Slorach Date: 31/08/2020 Approved By: Troy Slorach Date: 31/08/2020
 Rev. No: 1 Date Implemented: 31/08/2020

250HR LUBE SERVICE - TRACTOR		INITIALS
SAMPLE:	Engine	Pm
	Transmission	Pm
CHANGE:		
	Engine oil	Pm
	Engine oil filter	Pm
	Primary air filter	Pm
	Fuel filter	Pm
	Cab air conditioner filters	Pm
	Fuel water separator	Pm
CLEAN:		
	Transmission screens	Pm
	Radiator and air conditioner condenser	Pm
	Batteries, terminals and battery box	Pm
	Air conditioner evaporator	Pm
	Torque converter scavenge screen	Pm
	Drain water from air tanks	Pm
	Drain water and sediment from fuel tank	Pm
CHECK:		
	Coolant level	Pm
	Hydraulic oil level	Pm
	Differential oil level	Pm
	Final drive oil levels	
	Transmission oil levels	Pm

MAGNETIC PLUGS (If applicable) :						
OK - OK	P- PASTE		P1	P2	P3	P4
HP - HEAVY PASTE	LF - LIGHT FLAKES	HF - HEAVY FLAKES	OK.	OK.	OK.	OK.

Note: The electronic copy of this document is controlled. To ensure that other copies of this document are current, check the revision number and date against the compliance management database, Qudos

Prepared By: Troy Slorach Date: 31/08/2020 Approved By: Troy Slorach Date: 31/08/2020
 Rev. No: 1 Date Implemented: 31/08/2020



GREASE:		INITIALS
	Check cushion hitch accumulator pressure	Pm
	Fill bulk grease tank	Pm
	Ejector floor rollers	Pm
	Slack adjuster and brake S cams	Pm
	All pins receiving grease	Pm
250HR LUBE SERVICE - TRAILER		
SAMPLE:		
	Engine	Pm
	Transmission	Pm
CHANGE:		
	Engine oil	Pm
	Engine oil filters	Pm
	Primary air filters	Pm
	Fuel filters	Pm
CLEAN:		
	Transmission screens	Pm
	Primary fuel screen	Pm
	Radiator air conditioner condenser	Pm
	Batteries and terminals	Pm
	Torque converter scavenge screen	Pm
	Drop box scavenge screen	Pm
	Drain water from air tanks	Pm
	Drain water and sediment from fuel tank	Pm
CHECK:		
	Coolant level	Pm
	Differential oil level	Pm
	Final drive oil level	Pm
	Transmission oil level	Pm

Note: The electronic copy of this document is controlled. To ensure that other copies of this document are current, check the revision number and date against the compliance management database, Qudos

Prepared By: Troy Slorach Date: 31/08/2020 Approved By: Troy Slorach Date: 31/08/2020
Rev. No: 1 Date Implemented: 31/08/2020

GREASE:	INITIALS
Rear brake actuators and S cams	M
All pins receiving grease	M

250 HR MECHANICAL SERVICE

1. Machine is not safe, defect must be repaired
2. Defect found and recorded, machine safe to operate
3. Defect found and repaired
4. OK
5. Not applicable

CHECK:	1	2	3	4	5
Air conditioner – condition and operation				✓	
Check and clear ECM faults				/	
Hydraulic pump bolt torque				/	
Steering pump mount bolt torque				/	
Engine mount bolt torque				/	
No visible leaks				/	
Check cabin, dash screws, pedal rubber etc				/	
Steering (cylinders, valve and joints)				/	
Induction system for leaks and clamps for tightness				/	
All hoses for general condition and chaffing				/	
Fuel system for loose bolts and fittings				/	
Fuel line pipe support clamps				/	
Hydraulic system for damaged lines and loose fittings				/	
Engine mounts				/	
Transmission and diff mount bolts				/	
All panels and guards				/	
Exhaust leaks				/	
Frame for cracks – record on inspection sheet				/	
Retarder lever free play				/	
Remove covers and inspect brake linings				/	
Inspect fan and jockey pulley bearings				/	
Condition and tension of V belts / multi rib belts				/	
Radiator for debris (wash if necessary)				/	

Note: The electronic copy of this document is controlled. To ensure that other copies of this document are current, check the revision number and date against the compliance management database, Qudos

Prepared By: Troy Slorach Date: 31/08/2020 Approved By: Troy Slorach Date: 31/08/2020
 Rev. No: 1 Date Implemented: 31/08/2020



CHECK:	1	2	3	4	5
Cooling system hoses for condition and clamps for tightness				/	
Battery hold down clamps				/	
All points are receiving grease				/	
Check system voltages				/	

CHECK: Tyre pressures					
P1	RADIAL	75PSI	P2	RADIAL	75PSI
SPEC:	NYLON	70PSI	SPEC:	NYLON	70PSI
P1	RADIAL	75	P2	RADIAL	75
ACTUAL:	NYLON		ACTUAL:	NYLON	
P3	RADIAL	70PSI	P4	RADIAL	70PSI
SPEC:	NYLON	70PSI	SPEC:	NYLON	70PSI
P3	RADIAL	75	P4	RADIAL	75
ACTUAL:	NYLON		ACTUAL:	NYLON	

SAFETY CHECK TO BE CARRIED OUT EVERY SERVICE					
<p>NOTE: Boxes A - F are to be initialled by person carrying out safety checks. Every person carrying out these checks must also sign off Safety Check Sheet before the end of each shift.</p>					
<p>KEY:</p> <ol style="list-style-type: none"> Machine is not safe, defect must be repaired Defect found and recorded, machine safe to operate Defect found and repaired OK Not applicable 					
CHECK:	1	2	3	4	5
Service brake operation stall test				/	
Emergency brake				/	
Park brake operation				/	
Retarder operation				/	
Steering operation				/	
Seats – suspension adjustment/condition				/	

Note: The electronic copy of this document is controlled. To ensure that other copies of this document are current, check the revision number and date against the compliance management database, Qudos

Prepared By: Troy Slorach Date: 31/08/2020 Approved By: Troy Slorach Date: 31/08/2020
 Rev. No: 1 Date Implemented: 31/08/2020



CHECK:	1	2	3	4	5
Seat belt – retainers and operation				✓	
Doors				✓	
Windows				✓	
Mirrors				✓	
Cab conditions				✓	
Horns – air and electric				✓	
Wipers				✓	
Washer bottle full				✓	
Gauges				✓	
Audible alarm and warning lights				✓	
Lights				✓	
Reverse alarm				✓	
Operation of emergency stops				✓	
Two way radio operation				✓	
Grab rails				✓	
Steps				✓	
Fire extinguishers – check condition and last service date:				✓	
Fire suppression bottle charge date and condition				✓	
Tyre condition				✓	
Wheel nuts				✓	
Fuel leaks				✓	
Pin retainers				✓	
Accumulation of fuel, oil, grease etc. that may cause fire hazard				✓	

Note: The electronic copy of this document is controlled. To ensure that other copies of this document are current, check the revision number and date against the compliance management database, Qudos

Prepared By: Troy Slorach Date: 31/08/2020 Approved By: Troy Slorach Date: 31/08/2020
Rev. No: 1 Date Implemented: 31/08/2020

