

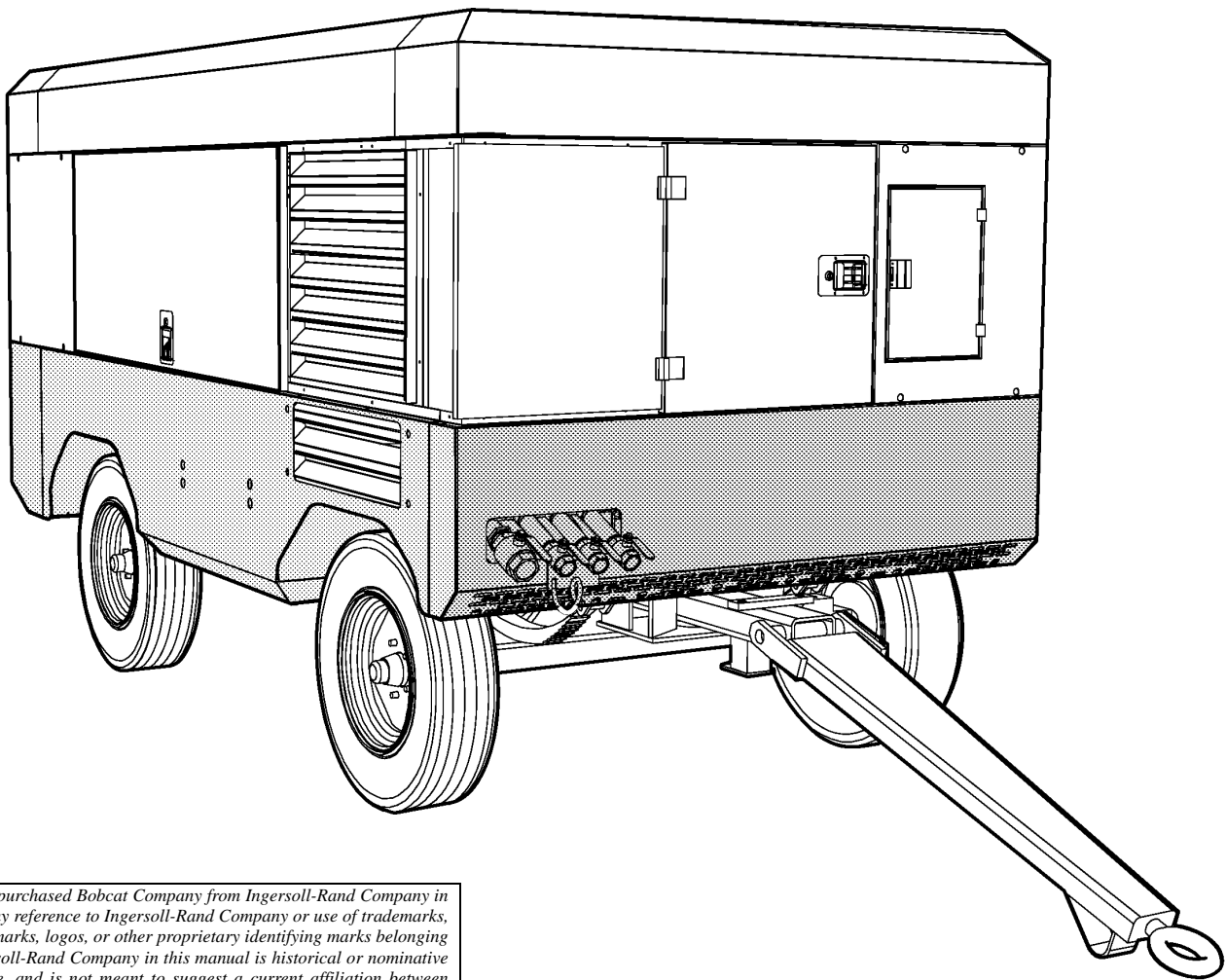

Ingersoll-Rand®

9/230, 9/270, 9/300, 12/235, 17/235, 21/215
9/230HA, 9/270HA, 9/300HA, 12/235HA, 17/235HA, 21/215HA

OPERATION AND MAINTENANCE MANUAL



Doosan purchased Bobcat Company from Ingersoll-Rand Company in 2007. Any reference to Ingersoll-Rand Company or use of trademarks, service marks, logos, or other proprietary identifying marks belonging to Ingersoll-Rand Company in this manual is historical or nominative in nature, and is not meant to suggest a current affiliation between Ingersoll-Rand Company and Doosan Company or the products of either.



This manual contains important safety information and must be made available to personnel who operate and maintain this machine.

IR 9/230, 9/270,
9/300, 12/335

SERIAL No : 892000 →

IR 17/235,
21/215

SERIAL No : 881000 →

C.C.N. : 22163448 GB
DATE : MARCH 2003
Revised (10-12)

Machine models represented in this manual may be used in various locations world-wide. Machines sold and shipped into European Union Territories require that the machine display the EC Mark and conform to various directives. In such cases, the design specification of this machine has been certified as complying with EC directives. Any modification to any part is absolutely prohibited and would result in the CE Certification and marking being rendered invalid. A declaration of that conformity follows:



DECLARATION OF CONFORMITY WITH EC DIRECTIVES

98/37/EC, 93/68/EEC, 89/336/EEC, 2000/14/EC

We

Ingersoll-Rand Company
 Portable Compressor Division
 P.O. Box 868
 501 Sanford Avenue
 Mocksville, North Carolina 27028

Represented in EC by:

Ingersoll-Rand Company Limited
 Standard Products Division
 Swan Lane
 Hindley Green
 Wigan WN2 4EZ
 United Kingdom

Declare that, under our sole responsibility for manufacture and supply, the product(s)

9/230, 9/270, 9/300, 12/235, 17/235, 21/215

to which this declaration relates, is (are) in conformity with the provisions of the above directives using the following principal standards

EN29001 : EN292, EN60204-1, EN1012-1, PN8NTC2, EN50081 EN50082

Issued at Mocksville on
 1-1-2003

Ric Lunsford
 Manager of quality control

CONFORMITY WITH NOISE DIRECTIVE 2000/14/EC

Ingersoll-Rand Company Limited declare that the following Portable Compressors have been manufactured in conformity with the directive as shown

Directive	Machine Type	kW	Serial number range	Mean measured value	Guaranteed Level	Notified body
2000/14/EC Annex VI Part I	9/230	224	892000-899999	100.3 L _{WA}	102 L _{WA}	A V Technology Stockport UK Nr 1067
	9/270					
	12/235					
2000/14/EC Annex VI Part I	9/300	255	881000-889999	100.3 L _{WA}	102 L _{WA}	A V Technology Stockport UK Nr 1067
	17/235					
	21/215					

Issued at Mocksville
 1st Declaration 18-02-03

Quality assurance manager

EC Pressure Equipment Directive and Related Regulations

We declare that this product has been assessed according to the Pressure Equipment Directive (97/23/EC) and, in accordance with the terms of this Directive, has been excluded from the scope of this Directive. It may carry "CE" marking in compliance with other applicable EC Directives.

CONTENTS		ABBREVIATIONS & SYMBOLS	
1	CONTENTS	####	Contact Ingersoll–Rand for serial number
2	FOREWORD	->####	Up to Serial No.
		####->	From Serial No.
4	WARRANTY	*	Not illustrated
11	ISO SYMBOLS	†	Option
14	SAFETY	WDG	Generator option
16	GENERAL INFORMATION Dimensions Data	AR	As required
19	OPERATING INSTRUCTIONS Commissioning Prior to starting Starting Stopping Emergency stopping Re-starting Monitoring during operation Decommissioning	BR	Brazil
28	MAINTENANCE Routine maintenance Lubrication Speed & pressure regulation Torque settings table Compressor lubrication	CN	China
40	MACHINE SYSTEMS Electrical system Piping & instrumentation system	DE	Germany
45	FAULT FINDING	DK	Denmark
47	OPTIONS	ES	Spain
49	PARTS ORDERING	FI	Finland
		FR	France
		GB	Great Britain (English)
		HA	High ambient machine
		IT	Italy
		NL	Holland
		NO	Norway
		PT	Portugal
		SE	Sweden
		US	United States
		S.R.G.	Site running gear
		H.R.G.	High speed running gear

2 FOREWORD

The contents of this manual are considered to be proprietary and confidential to Ingersoll–Rand and should not be reproduced without the prior written permission of Ingersoll–Rand.

Nothing contained in this document is intended to extend any promise, warranty or representation, expressed or implied, regarding the Ingersoll–Rand products described herein. Any such warranties or other terms and conditions of sale of products shall be in accordance with the standard terms and conditions of sale for such products, which are available upon request.

This manual contains instructions and technical data to cover all routine operation and scheduled maintenance tasks by operation and maintenance staff. Major overhauls are outside the scope of this manual and should be referred to an authorised Ingersoll–Rand service department.

The design specification of this machine has been certified as complying with EC directives. As a result:

(a) Any machine modifications are strictly prohibited, and will invalidate EC certification.

(b) This machine may be used in USA / Canada, when configured with components bearing the appropriate certification. (Where ASME certification is valid).

All components, accessories, pipes and connectors added to the compressed air system should be:

- . of good quality, procured from a reputable manufacturer and, wherever possible, be of a type approved by Ingersoll–Rand.
- . clearly rated for a pressure at least equal to the machine maximum allowable working pressure.
- . compatible with the compressor lubricant/coolant.
- . accompanied with instructions for safe installation, operation and maintenance.

Details of approved equipment are available from Ingersoll–Rand Service departments.

The use of repair parts / lubricants / fluids other than those included within the Ingersoll–Rand approved parts list may create hazardous conditions over which Ingersoll–Rand has no control. Therefore Ingersoll–Rand cannot be held responsible for equipment in which non–approved repair parts are installed.

Ingersoll–Rand reserves the right to make changes and improvements to products without notice and without incurring any obligation to make such changes or add such improvements to products sold previously.

The intended uses of this machine are outlined below and examples of unapproved usage are also given, however Ingersoll–Rand cannot anticipate every application or work situation that may arise.

IF IN DOUBT CONSULT SUPERVISION.

This machine has been designed and supplied for use only in the following specified conditions and applications:

- . Compression of normal ambient air containing no known or detectable additional gases, vapours, or particles
- . Operation within the ambient temperature range specified in the *GENERAL INFORMATION* section of this manual.

The use of the machine in any of the situation types listed in table 1:-

- a) Is not approved by Ingersoll-Rand,
- b) May impair the safety of users and other persons, and
- c) May prejudice any claims made against Ingersoll-Rand.

TABLE 1
Use of the machine to produce compressed air for: a) direct human consumption b) indirect human consumption, without suitable filtration and purity checks.
Use of the machine outside the ambient temperature range specified in the <i>GENERAL INFORMATION SECTION</i> of this manual.
Use of the machine where there is any actual or foreseeable risk of hazardous levels of flammable gases or vapours.
Use of the machine fitted with non Ingersoll-Rand approved components / lubricants / fluids.
Use of the machine with safety or control components missing or disabled.

The company accepts no responsibility for errors in translation of this manual from the original English version.

© COPYRIGHT 2003
INGERSOLL-RAND COMPANY

4 WARRANTY

Ingersoll-Rand, through its distributor, warrants that each item of equipment manufactured by it and delivered hereunder to the initial user will be free of defects in material and workmanship for a period of three (3) months from initial operation or six (6) months from the date of shipment to the initial user, whichever occurs first.

With respect to the following types of equipment, the warranty period enumerated below will apply in lieu of the foregoing warranty period.

- A. **Aftercoolers** – The earlier of nine (9) months from date of shipment to or six (6) months from start up by initial user.
- B. **Portable Compressors, Portable Generator Sets – 9 Kva through to 550 Kva, Portable Light Towers and Air Dryers** – The earlier of twelve (12) months from shipment to or the accumulation of 2,000 hours of service by the initial user.

2.5 Kva Through to 8 Kva – The earlier of twelve (12) months from shipment to or the accumulation of 2,000 hours of operation by the initial user.

Ingersoll-Rand will provide a new part or repaired part, at its sole discretion, in place of any part which is found to be defective in material or workmanship during the period described above. Labor cost to replace the part is the responsibility of the initial user.

- C. **Portable Compressor Air Ends** – The earlier of twenty-four (24) months from shipment to or the accumulation of 4,000 hours of service by the initial user. For Air Ends, the warranty against defects will include replacement of the complete Air End, provided the original Air End is returned assembled and all original seals are intact.
- C1. **Portable Compressor Airend Limited Extended Warranty** – The earlier of sixty (60) months from shipment to or the accumulation of 10,000 hours of operation by the initial user. This extended warranty is limited to defects in design or defective material or workmanship in rotors, housings, bearings and gears and provided all the following conditions are met:

The original air end is returned assembled and all original seals are intact.

Continued use of genuine Ingersoll-Rand parts, fluids, oils and filters.

Maintenance is performed at prescribed intervals by authorized and properly trained service engineers.

- D. **Generator Alternator – 9 Kva through to 550 Kva.** The earlier of twenty-four (24) months from shipment to or the accumulation of 4,000 hours of operation by the initial user.
2.5 Kva Through to 8 Kva – The earlier of twelve (12) months from shipment to or the accumulation of 2,000 hours of operation by the initial user.
- E. **Portable Light Tower Alternator** – The earlier of twelve (12) months from shipment to or the accumulation of 2,000 hours of operation by the initial user. Light Source model only, the earlier of twenty-four (24) months from shipment to or the accumulation of 4,000 hours of operation by the initial user.
- F. **Ingersoll-Rand Engines** – The earlier of twenty-four (24) months from shipment to or the accumulation of 4,000 hours of operation by the initial user.

- G. **Ingersoll-Rand Platinum Drive Train Limited Extended Warranty** – Platinum drive train refers to the Ingersoll-Rand Engine and Airend combination. The earlier of sixty (60) months from shipment to, or the accumulation of 10,000 hours of operation by the initial user. The starter, alternator, fuel injection system and all electrical components are excluded from this extended warranty. The airend seal and drive coupling are included in the warranty but airend drive belts are excluded. This limited extended warranty is automatically available when meeting the following conditions are met:

1. The original airend is returned assembled and unopened.
2. Continued use of genuine Ingersoll-Rand parts, fluids, oil and filters.
3. Maintenance is performed at prescribed intervals by authorized and properly trained service engineers.

Ingersoll-Rand shall be provided with such information as it requires to confirm that these conditions have been complied with.

- H1. **Construction Tools, (Portable Power range only)** – Twelve (12) months from shipment to initial user. Ingersoll-Rand will provide a new part or repaired part, at its sole discretion, in place of any part which is found to be defective in material or workmanship during the period described above. Labor cost to replace the part is the responsibility of the initial user.
- H2. **Construction Tools Limited Extended Warranty, (Portable Power range only)** – Thirty-six (36) months from shipment to initial user. This extended warranty is automatically available only when the tool is registered with Ingersoll-Rand by completing and submitting the Warranty Registration form. Ingersoll-Rand will provide a new part or repaired part, at its sole discretion, in place of any part which is found to be defective in material or workmanship during the period described above. Labor cost to replace the part is the responsibility of the initial user.
- I. **Spare Parts** – Six (6) months from date of shipment to the initial user.

Ingersoll-Rand will provide a new part or repaired part, at its sole discretion, in place of any part that is found to be defective in material and workmanship during the period described above. Such parts will be repaired or replaced without charge to the initial user during normal working hours at the place of business of an Ingersoll-Rand distributor authorized to sell the type of equipment involved or other establishment authorized by Ingersoll-Rand. User must present proof of purchase at the time of exercising warranty.

The above warranties do not apply to failures occurring as a result of abuse; misuse, negligent repairs, corrosion, erosion and normal wear and tear, alterations or modifications made to the product without express written consent of Ingersoll-Rand; or failure to follow the recommended operating practices and maintenance procedures as provided in the product's operating and maintenance publications.

Accessories or equipment furnished by Ingersoll-Rand, but manufactured by others, including, but not limited to, engines, tires, batteries, engine electrical equipment, hydraulic transmissions, carriers, shall carry only the manufacturers warranty, which Ingersoll-Rand can lawfully assign to the initial user.

THE ABOVE WARRANTIES ARE IN LIEU OF ALL OTHER WARRANTIES EXPRESSED OR IMPLIED, (EXCEPT THAT OF TITLE), AND THERE ARE NO WARRANTIES OF MERCHANTABILITY OR OF FITNESS FOR A PARTICULAR PURPOSE.

GENERAL WARRANTY INFORMATION – ESA

			COMMENTS
PORTABLE COMPRESSOR	PACKAGE	12 MONTHS / 2,000 HOURS	COVERS CONTROLS, SWITCHES, SHEET METAL, RADIATOR, OIL COOLER, RECEIVER, PIPEWORK, ELECTRICAL CIRCUIT ETC.
	AIREND	24 MONTHS / 4,000 HOURS	60 MONTHS / 10,000 HOURS. EXTENDED LIMITED WARRANTY AVAILABLE ON MAJOR COMPONENTS. REFER TO OPERATOR'S MANUAL.
	ENGINE	SEE BELOW	

2.5kVA – 8kVA GENERATORS	PACKAGE	12 MONTHS / 2,000 HOURS	CONTACT IR NETWORK FOR WARRANTY (PARTS ONLY NO LABOUR).
	ALTERNATOR	12 MONTHS / 2,000 HOURS	CONTACT IR NETWORK FOR WARRANTY (PARTS ONLY NO LABOUR).
	ENGINE	SEE BELOW	

9kVA – 550kVA GENERATORS	PACKAGE	12 MONTHS / 2,000 HOURS	COVERS CONTROLS, SWITCHES, SHEET METAL, ELECTRICAL CIRCUIT ETC.
	ALTERNATOR	24 MONTHS / 4,000 HOURS	CONTACT IR NETWORK FOR WARRANTY.
	ENGINE	SEE BELOW	

LIGHT TOWER	PACKAGE	12 MONTHS / 2,000 HOURS	COVERS CONTROLS, SWITCHES, SHEET METAL, ELECTRICAL CIRCUIT ETC.
	ALTERNATOR	12 MONTHS / 2,000 HOURS	EXTENDED WARRANTY OF 24 MONTHS / 4,000 HRS. FOR LIGHTSOURCE INTRODUCED 8/16/99.
	ENGINE	SEE BELOW	

ENGINES			
	MONTHS	HOURS	COMMENTS
CATERPILLAR	12	UNLIMITED	EXTENDED WARRANTY PROVIDED VIA ENGINE SUPPLIER'S OWN APPROVED NETWORK AT TIME OF PURCHASE.
CUMMINS	24	2,000	EXTENDED WARRANTY PROVIDED VIA ENGINE SUPPLIER'S OWN APPROVED NETWORK AT TIME OF PURCHASE.
PERKINS	12	UNLIMITED	IF UNDER 500 HOURS IN FIRST YEAR THEN BELOW APPLIES.
	24	1,000	ALL COMPONENTS COVERED EXCLUDING INJECTORS.
JOHN DEERE (IN COMPRESSORS) (IN GENERATORS)	24	2,000	5 YRS/5,000 HRS USING OEM FLUIDS AND FILTERS WITH \$250 DEDUCTABLE
	24	2,000	24 MONTHS / 4,000 HRS. AVAILABLE FROM IR WITH USE OF GENUINE IR PARTS AND OILS AT PRESCRIBED SERVICE INTERVALS. CONTACT IR NETWORK.
DEUTZ	0 – 12	UNLIMITED	ALL COMPONENTS COVERED.
	13 – 24	UNLIMITED	MAJOR COMPONENTS COVERED. FURTHER EXTENDED WARRANTY ON MAJOR COMPONENTS PROVIDED VIA ENGINE SUPPLIER'S OWN APPROVED NETWORK AT TIME OF PURCHASE.
INGERSOLL-RAND	24	4,000	EXTENDED WARRANTY OF 60 MONTHS / 10,000 HRS. WHEN USING GENUINE INGERSOLL-RAND FLUIDS AND PARTS ON MAJOR COMPONENTS.

6

WARRANTY

KUBOTA (North America only)	24	2,000	EXTENDED WARRANTY OF 36 MONTHS / 3,000 HRS. ON MAJOR COMPONENTS, PARTS ONLY, AVAILABLE FROM KUBOTA.
(Western Europe and Oceania)	24	2,000	NO EXTENDED WARRANTY AVAILABLE.
(Central and South America, Asia, Middle East and Africa)	12	1,000	NO EXTENDED WARRANTY AVAILABLE.
MITSUBISHI	24	2,000	2YRS / 4,000 HRS USING IR FLUIDS AND FILTERS
VOLVO	24	2,000	2YRS / 4,000 HRS USING IR FLUIDS AND FILTERS

PARTS			
	MONTHS	HOURS	COMMENTS
INGERSOLL-RAND	6	UNLIMITED	PARTS ONLY AVAILABLE FROM IR NETWORK.

AIREND EXCHANGE			
	MONTHS	HOURS	COMMENTS
AIREND	12	2,000	24 MONTHS / 4,000 HRS. AVAILABLE FROM IR NETWORK.

CONSTRUCTION TOOLS			
	MONTHS	HOURS	COMMENTS
CONSTRUCTION TOOLS	12	N/A	OPTIONAL 36 MONTHS EXTENDED WARRANTY AVAILABLE FROM IR. ALL WARRANTY COVERS PARTS ONLY REPLACEMENT.

**NOTE: Actual warranty times may change.
Consult the Manufacturer's warranty policy as shipped with each new product.**

Extended Limited Airend Warranty

Ingersoll–Rand Portable Compressor Division is pleased to announce the availability of extended limited airend warranty. Announcement of the extended warranty coincides with the introduction of Pro–Tec™ Compressor Fluid. Pro–Tec™ Compressor Fluid is an amber coloured fluid specially formulated for Portable Compressors and is being provided as the factory filled fluid for all machines except ¹ XHP650/900/1070

All machines have the standard airend warranty, – *The earlier of 24 months from shipment to, or the accumulation of 4000 hours of service by the initial user.*

The warranty against defects will include replacement of the complete Airend, provided the original Airend is returned assembled and unopened.

The optional limited warranty is the earlier of 60 months from shipment to, or the accumulation of 10,000 hours of service. The optional warranty is limited to defects in major components (rotors, housings, gears and bearings), and is automatically available when the following conditions are met:

1. The original airend is returned assembled and unopened.
2. Submissions of proof that Ingersoll–Rand fluid, filters and separators have been used. Refer to the Operation and Parts manual for the correct fluids, filters and separator elements required.
3. Submissions of proof that maintenance intervals have been followed.

WARRANTY	TIME	*BARE AIREND	**AIREND COMPONENTS
STANDARD	2YRS / 4,000HRS	100% PARTS & LABOUR	100% PARTS & LABOUR
OPTIONAL	5YRS / 10,000HRS	100% PARTS & LABOUR	0%

*BARE AIREND – pertains to major airend parts (rotors, housings, gears and bearings).

**AIREND COMPONENTS – pertains to auxiliary attachments to the bare airend (seals, pumps, valves, tubes, hoses, fittings and filter housing).

Pro–Tec™ and XHP505 Compressor Fluids are available from your local Ingersoll–Rand branch or distributor.

For units operating within the USA & Canada, call the Mocksville Product Support Department on 1–800–633–5206

¹ XHP650/900/1070/1170 will continue to use XHP505 and will have the extended warranty when above conditions are met.

WARRANTY REGISTRATION**FOR UNITS SOURCED FROM HORWICH, UK****Complete Machine Registration**

To initiate the machine warranty, fill out the "Warranty Registration" form 85040285 supplied as part of the machine documentation, keep a copy for your records and mail the original to:

**Ingersoll Rand European Sales Ltd
Portable Power Business
Swan Lane
Hindley Green
Wigan
Lancashire
WN2 4EZ
U.K.**

Attn: Customer Service Department

Note: Completion of this form validates the warranty.

Engine Registration:

I-R powered machines do not require separate engine registration.

Deutz require a separate engine registration form to be completed and mailed direct to their Cologne office. The form is supplied as part of the machine documentation for Deutz powered machines.

Caterpillar, Cummins and Perkins do not require a separate registration form but they stipulate that any new engine should be registered with their local dealer to initiate warranty.

You **MUST** provide proof of the "in-service" date when requesting engine warranty repairs.

WARRANTY REGISTRATION

FOR UNITS SOURCED FROM MOCKSVILLE, USA

Complete Machine Registration

Machines shipped to locations within the United States do not require a warranty registration unless the machine status changes (i.e. change of ownership).

Machines shipped outside the United States require notification be made to initiate the machine warranty.

Fill out the Warranty Registration Form in this section, keep a copy for your records and mail form to:

Ingersoll-Rand Company
P.O. Box 868
Mocksville, North Carolina 27028
Attn: Warranty Department

Note: Completion of this form validates the warranty.

Engine Registration:

I-R powered machines do not require separate engine registration.

John Deere requires a separate engine registration be completed and mailed direct to John Deere.

Separate engine registration material is included with this literature package for John Deere powered machines.

All other engine manufacturers do not require a separate engine registration.

You **MUST** present proof of in-service date at time of requesting engine warranty service.

**PORTABLE POWER
EXTENDED WARRANTY REGISTRATION FORM****Customer Details**

Company Name : _____

Contact Name : _____

Signature : _____

Company Address : _____

Post / Zip Code : _____

Country : _____

Phone Number : _____

Fax Number : _____

e-mail : _____

Service Provider Details

Service Provider / Distributor : _____

Branch Office : _____

Machine Details

Product Type : _____

Model : _____

Serial Number : _____

Engine Serial Number : _____

Engine Model Number : _____











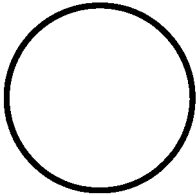
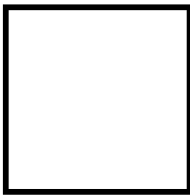

Airend Serial Number : _____

Alternator Serial Number : _____

Date of start up : _____

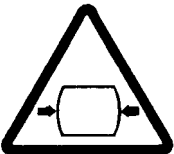
SAMPLE

GRAPHIC FORM AND MEANING OF ISO SYMBOLS

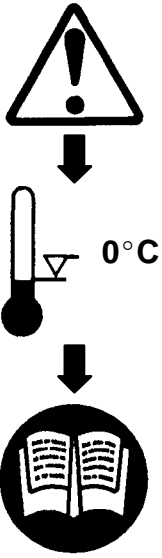
		
Prohibition / Mandatory	Information / Instructions	Warning
 <p>WARNING: Electrical shock risk.</p>	 <p>WARNING – Pressurised component or system.</p>	 <p>WARNING – Hot surface.</p>
 <p>WARNING – Pressure control.</p>	 <p>WARNING – Corrosion risk.</p>	 <p>WARNING – Air/gas flow or Air discharge.</p>
 <p>WARNING – Pressurised vessel.</p>	 <p>WARNING – Hot and harmful exhaust gas.</p>	 <p>WARNING – Maintain correct tyre pressure. (Refer to the GENERAL INFORMATION section of this manual).</p>
 <p>WARNING – Flammable liquid.</p>	 <p>WARNING – Before connecting the tow bar or commencing to tow consult the operation and maintenance manual.</p>	 <p>WARNING – For operating temperature below 0°C, consult the operation and maintenance manual.</p>

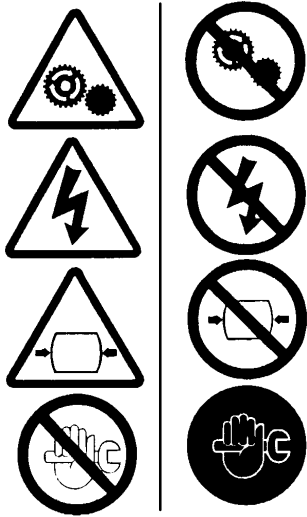

WARNING – Do not undertake any maintenance on this machine until the electrical supply is disconnected and the air pressure is totally relieved.



WARNING – Consult the operation and maintenance manual before commencing any maintenance.



Do not breathe the compressed air from this machine.



Do not remove the Operating and Maintenance manual and manual holder from this machine.



Do not stack.



Do not operate the machine without the guard being fitted.



Do not stand on any service valve or other parts of the pressure system.



Do not operate with the doors or enclosure open.



Do not use fork lift truck from this side.



Do not exceed the trailer speed limit.



No naked lights.



Do not open the service valve before the airhose is attached.



Use fork lift truck from this side only.

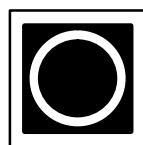

Emergency stop.



Tie down point



Lifting point.



On (power).

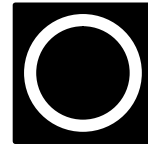

Off (power).



Read the Operation and Maintenance manual before operation or maintenance of this machine is undertaken.

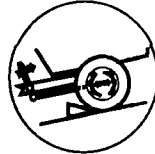

When parking use prop stand, handbrake and wheel chocks.



Compressor oil filling

WARNINGS

Warnings call attention to instructions which must be followed precisely to avoid injury or death.

CAUTIONS

Cautions call attention to instructions which must be followed precisely to avoid damaging the product, process or its surroundings.

NOTES

Notes are used for supplementary information.

General Information

Ensure that the operator reads and *understands* the decals and consults the manuals before maintenance or operation.

Ensure that the Operation and Maintenance manual, and the manual holder, are not removed permanently from the machine.

Ensure that maintenance personnel are adequately trained, competent and have read the Maintenance Manuals.

Make sure that all protective covers are in place and that the canopy/doors are closed during operation.

The specification of this machine is such that the machine is not suitable for use in flammable gas risk areas. If such an application is required then all local regulations, codes of practice and site rules must be observed. To ensure that the machine can operate in a safe and reliable manner, additional equipment such as gas detection, exhaust spark arrestors, and intake (*shut-off*) valves may be required, dependant on local regulations or the degree of risk involved.

A weekly visual check must be made on all fasteners/fixing screws securing mechanical parts. In particular, safety-related parts such as coupling hitch, drawbar components, road-wheels, and lifting bail should be checked for total security.

All components which are loose, damaged or unserviceable, must be rectified without delay.

Compressed air

Compressed air can be dangerous if incorrectly handled. Before doing any work on the unit, ensure that all pressure is vented from the system and that the machine cannot be started accidentally.

Ensure that the machine is operating at the rated pressure and that the rated pressure is known to all relevant personnel.

All air pressure equipment installed in or connected to the machine must have safe working pressure ratings of at least the machine rated pressure.

If more than one compressor is connected to one common downstream plant, effective check valves and isolation valves must be fitted and controlled by work procedures, so that one machine cannot accidentally be pressurised / over pressurised by another.

Compressed air must not be used for a direct feed to any form of breathing apparatus or mask.

The discharged air contains a very small percentage of compressor lubricating oil and care should be taken to ensure that downstream equipment is compatible.

If the discharged air is to be ultimately released into a confined space, adequate ventilation must be provided.

When using compressed air always use appropriate personal protective equipment.

All pressure containing parts, especially flexible hoses and their couplings, must be regularly inspected, be free from defects and be replaced according to the Manual instructions.

Avoid bodily contact with compressed air.

The safety valve located in the separator tank must be checked periodically for correct operation.

Materials

The following substances *may* be produced during the operation of this machine:

- . brake lining dust
- . engine exhaust fumes

AVOID INHALATION

Ensure that adequate ventilation of the cooling system and exhaust gases is maintained at all times.

The following substances are used in the manufacture of this machine and *may* be hazardous to health if used incorrectly:

- . anti-freeze
- . compressor lubricant
- . engine lubricant
- . preservative grease
- . rust preventative
- . diesel fuel
- . battery electrolyte

AVOID INGESTION, SKIN CONTACT AND INHALATION OF FUMES

Should compressor lubricant come into contact with the eyes, then irrigate with water for at least 5 minutes.

Should compressor lubricant come into contact with the skin, then wash off immediately.

Consult a physician if large amounts of compressor lubricant are ingested.

Consult a physician if compressor lubricant is inhaled.

Never give fluids or induce vomiting if the patient is unconscious or having convulsions.

Safety data sheets for compressor and engine lubricants should be obtained from the lubricant supplier.

Battery

Batteries contain corrosive liquid and produce explosive gas. Do not expose to naked lights. Always wear personal protective clothing when handling. When starting the machine from a slave battery ensure that the correct polarity is observed and that connections are secure.

DO NOT ATTEMPT TO SLAVE START A FROZEN BATTERY SINCE THIS MAY CAUSE IT TO EXPLODE.

Radiator

Hot engine coolant and steam can cause injury. Ensure that the radiator filler cap is removed with due care and attention.

Engine starting fluid (ether)

Use and recharge system only with suppliers instructions and replacement parts.

Some machines are fitted with an ether cold starting aid.

Do **NOT** use on engines which are provided with inlet heaters.

AVOID INGESTION, INHALATION, HOT SURFACES AND NAKED LIGHTS

Transport

When loading or transporting machines ensure that the specified lifting and tie down points are used.

When loading or transporting machines ensure that the towing vehicle, its size, weight, towing hitch and electrical supply are all suitable to provide safe and stable towing at speeds either, up to the legal maximum for the country in which it is being towed or, as specified for the machine model if lower than the legal maximum.

Before towing the machine, ensure that:-

- . the tyres and towing hitch are in a serviceable condition.
- . the canopy is secure.
- . all ancillary equipment is stored in a safe and secure manner.

When parking always use the handbrake and, if necessary, suitable wheel chocks.

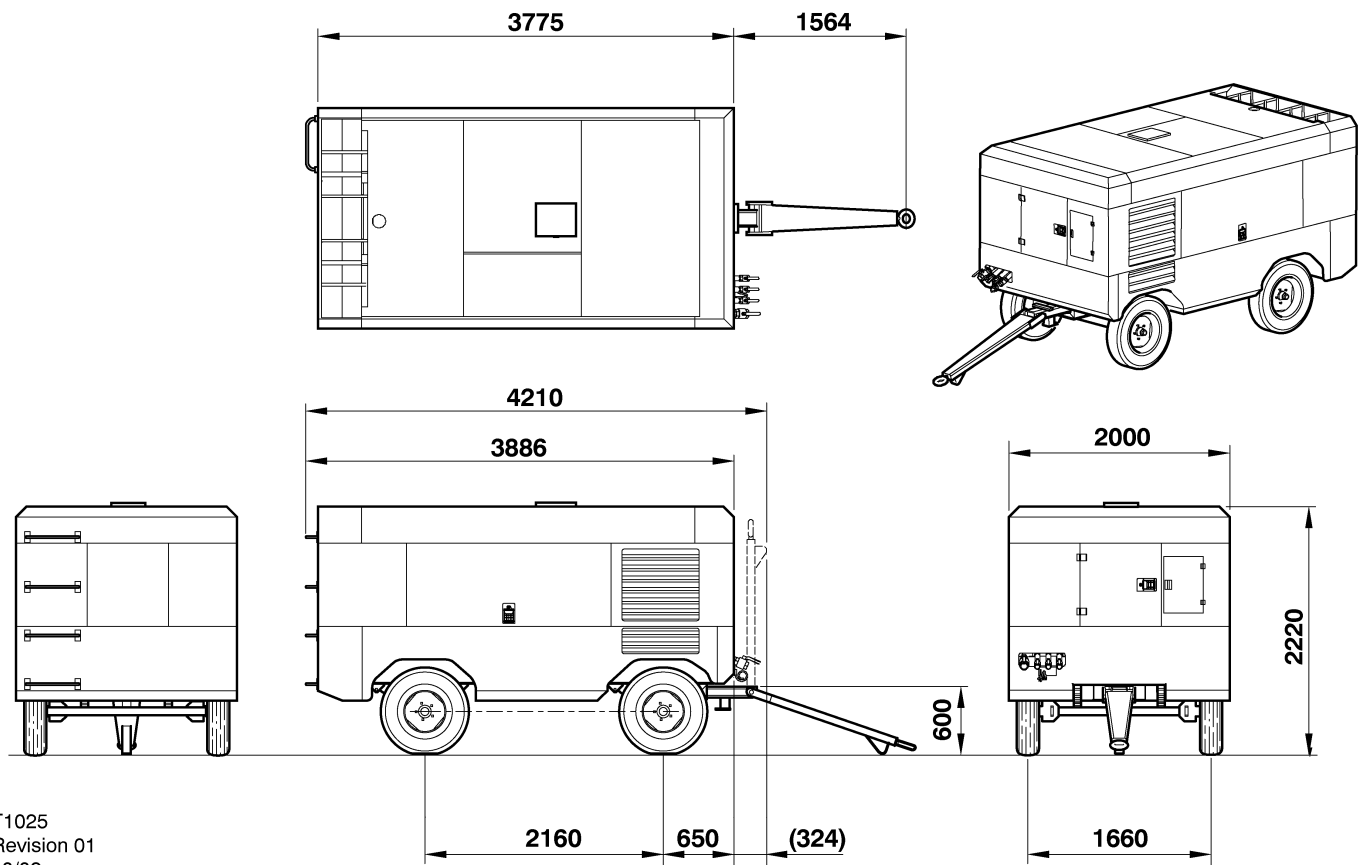

T1025
Revision 01
10/02

'CE'

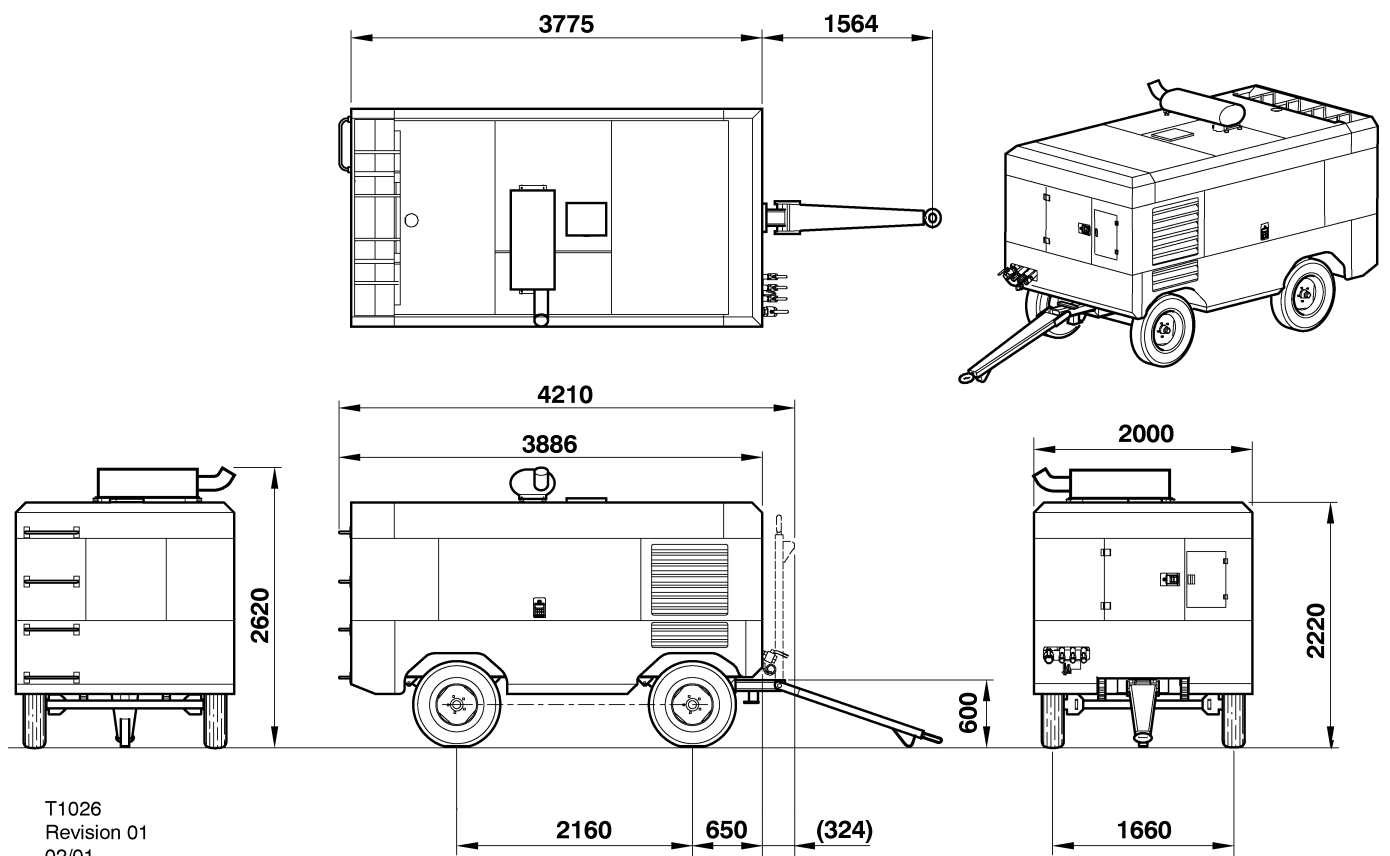

T1026
Revision 01
02/01

'HA'

MODEL		9/235	12/235	9/270	9/300	21/215	17/235
COMPRESSOR							
Actual free air delivery.	m ³ /min/ cfm	23,3/ 825	23,3/ 825	25,6/ 900	29,9/ 1060	21,5/ 750	23,3/ 825
Normal operating discharge pressure.	psi/bar/ kPa	125/8,6/ 860	175/12/ 1200	125/8,6/ 860	125/8,6/ 860	300/21/ 2100	250/17,2/ 1724
Maximum allowable pressure	psi/bar/ kPa	145/10/ 1000	190/13,1/ 1310	145/10/ 1000	145/10/ 1000	350/24/ 2400	350/24/ 2400
Safety valve setting	psi/bar/ kPa	217/15/ 1500	217/15/ 1500	217/15/ 1500	217/15/ 1500	362/25/ 2500	362/25/ 2500
Maximum pressure ratio (absolute)		8:1	8:1	8:1	8:1	18:9:1	18:9:1
Operating ambient temperature range	°C	-10/+50	-10/+50	-10/+50	-10/+50	-10/+50	-10/+50
Maximum discharge temperature	°C	120	120	120	120	120	120
COMPRESSOR							
Cooling system.		Oil Injection					
Oil capacity.	Litre	70	70	70	70	75	75
Maximum oil system temperature	°C	120	120	120	120	120	120
Maximum oil system pressure	psi/bar/ kPa	217/15/ 1500	217/15/ 1500	217/15/ 1500	217/15/ 1500	362/25/ 2500	362/25/ 2500
LUBRICATING OIL SPECIFICATION (for the specified ambient temperatures).		SEE NOTE – 1					
ENGINE							
Type/model.		9/235 IR 6IRQ9AE	12/235 IR 6IRQ9AE	9/270 IR 6IRQ9AE	9/300 IR 6IRQ9AE	21/215 IR 6IRQ9AE	17/235 IR 6IRQ9AE
Number of cylinders / Displacement	/Litre	6/8,9	6/8,9	6/8,9	6/8,9	6/8,9	6/8,9
Oil capacity.	Litre	24	24	24	24	24	24
Speed at full load.	Rev min ⁻¹	1800	1800	1800	1800	1800	1800
Speed at idle.	Rev min ⁻¹	1200	1200	1200	1200	1300	1300
Electrical system.	V DC	24	24	24	24	24	24
Power available at rated speed	KW	224	224	224	255	255	255
Fuel tank capacity.	Litre	550	550	550	550	550	550
Coolant capacity	Litre	48	48	48	48	48	48
Max. gross weight	kg	4820	4820	4820	4820	4820	4820
Shipping weight	kg	4340	4340	4340	4340	4340	4340

NOTE – 1**ABOVE –23°C**

Recommended: Pro-Tec™
Approved: SAE 10W, API CF-4/CG-4

BELOW –23°C

Mandatory: IR Performance 500

Ingersoll-Rand Pro-Tec™ compressor fluid is factory-fitted, for use at all ambient temperatures above –23°C.

NOTE: Warranty may be extended only by continuous use of Pro-Tec™ and Ingersoll-Rand oil filters and separators.

No other oil/fluids are compatible with Pro-Tec™

No other oils/fluids should be mixed with Pro-Tec™ because the resulting mixture could cause damage to the airend.

In the event that Pro-Tec™ is not available and / or the end user needs to use an approved single grade engine oil, the complete system including separator / receiver, cooler and pipework must be flushed clear of the first fill fluid and new Ingersoll-Rand oil filters installed. When this has been completed, the following oils are approved:

- a) for ambient temperatures above –23°C,
SAE 10W, API CF-4/CG-4
- b) for ambient temperatures below –23°C,
I-R Performance 500 only.

SOUND LEVEL DATA ('W' model)

A) To Pneurop code PN8NTC2.
Equivalent continuous sound pressure level.*

Rated load 83 dB(A) Estimated
(Operator position :–1m from machine)

B) In compliance with 86/188/EEC.

Average sound pressure level at 10m
to 79/113/EEC.* 72dB(A)

(*Machine only :– at maximum load in open site conditions)

C) US EPA 76dB(A)

Shipping weight. 4340 kg

Maximum weight. 4820 kg

Maximum horizontal towing force. 4714 kgf Estimated

WHEELS AND TYRES – SITE RUNNING GEAR

Number of wheels. 4

Tyre size. 750x16x6PR

Tyre pressure. 3,5 bar (50 lbf in⁻²)

TOWING SPEED

Maximum towing speed 30 km h⁻¹
(20 mile h⁻¹)

Further information may be obtained by request through Ingersoll-Rand customer services department.

COMMISSIONING

Upon receipt of the unit, and prior to putting it into service, it is important to adhere strictly to the instructions given below in *PRIOR TO STARTING*.

Ensure that the operator reads and *understands* the decals and consults the manuals before maintenance or operation.

Ensure that the position of the *emergency stop* device is known and recognised by its markings. Ensure that it is functioning correctly and that the method of operation is known.

Before towing the unit, ensure that the tyre pressures are correct (refer to the *GENERAL INFORMATION* section of this manual) and that the handbrake is functioning correctly (refer to the *MAINTENANCE* section of this manual). Before towing the unit during the hours of darkness, ensure that the lights are functioning correctly (where fitted).

Ensure that all transport and packing materials are discarded.

Ensure that the correct fork lift truck slots or marked lifting / tie down points are used whenever the machine is lifted or transported.

When selecting the working position of the machine ensure that there is sufficient clearance for ventilation and exhaust requirements, observing any specified minimum dimensions (to walls, floors etc.).

Adequate clearance needs to be allowed around and above the machine to permit safe access for specified maintenance tasks.

Ensure that the machine is positioned securely and on a stable foundation. Any risk of movement should be removed by suitable means, especially to avoid strain on any rigid discharge piping.

Attach the battery cables to the battery(s) ensuring that they are tightened securely. Attach the negative cable before attaching the positive cable

WARNING: All air pressure equipment installed in or connected to the machine must have safe working pressure ratings of at least the machine rated pressure, and materials compatible with the compressor lubricant (refer to the *GENERAL INFORMATION* section).

WARNING: If more than one compressor is connected to one common downstream plant, effective check valves and isolation valves must be fitted and controlled by work procedures, so that one machine cannot accidentally be pressurised / over pressurised by another.

WARNING: If flexible discharge hoses are to carry more than 7 bar pressure then it is recommended that safety retaining wires are used on the hoses.

20 OPERATING INSTRUCTIONS

PRIOR TO STARTING

1. Place the unit in a position that is as level as possible. The design of the unit permits a 15 degree lengthways and sideways limit on out of level operation. It is the engine, not the compressor, that is the limiting factor.

When the unit has to be operated out of level, it is important to keep the engine oil level near the high level mark (with the unit level).

CAUTION: Do not overfill either the engine or the compressor with oil.

2. Check the engine lubrication oil in accordance with the operating instructions in the *Engine Operator's Manual*.

3. Check the compressor oil level in the sight glass located on the separator tank.

4. Check the diesel fuel level. A good rule is to top up at the end of each working day. This prevents condensation from occurring in the tank.

CAUTION: Use only a No. 2-D diesel fuel oil with a minimum octane number of 45 and a sulphur content not greater than 0,5%.

CAUTION: When refuelling:—

- switch off the engine.
- do not smoke.
- extinguish all naked lights.
- do not allow the fuel to come into contact with hot surfaces.
- wear personal protective equipment.

5. Drain fuel filter water separator of water ensuring that any released fuel is safely contained.

6. Check the radiator coolant level (with the unit level).

7. Open the service valve(s) to ensure that all pressure is relieved from the system. Close the service valve(s).

8. **CAUTION:** Do not operate the machine with the canopy/doors in the open position as this may cause overheating and operators to be exposed to high noise levels.

9. Check the emergency stop. Rotate knob as indicated to release.

10. Close the manual relief valve inside the service door near the emergency stop.

When starting or operating the machine in temperatures below or approaching 0°C, ensure that the operation of the regulation system, the unloader valve, the safety valve, and the engine are not impaired by ice or snow, and that all inlet and outlet pipes and ducts are clear of ice and snow.

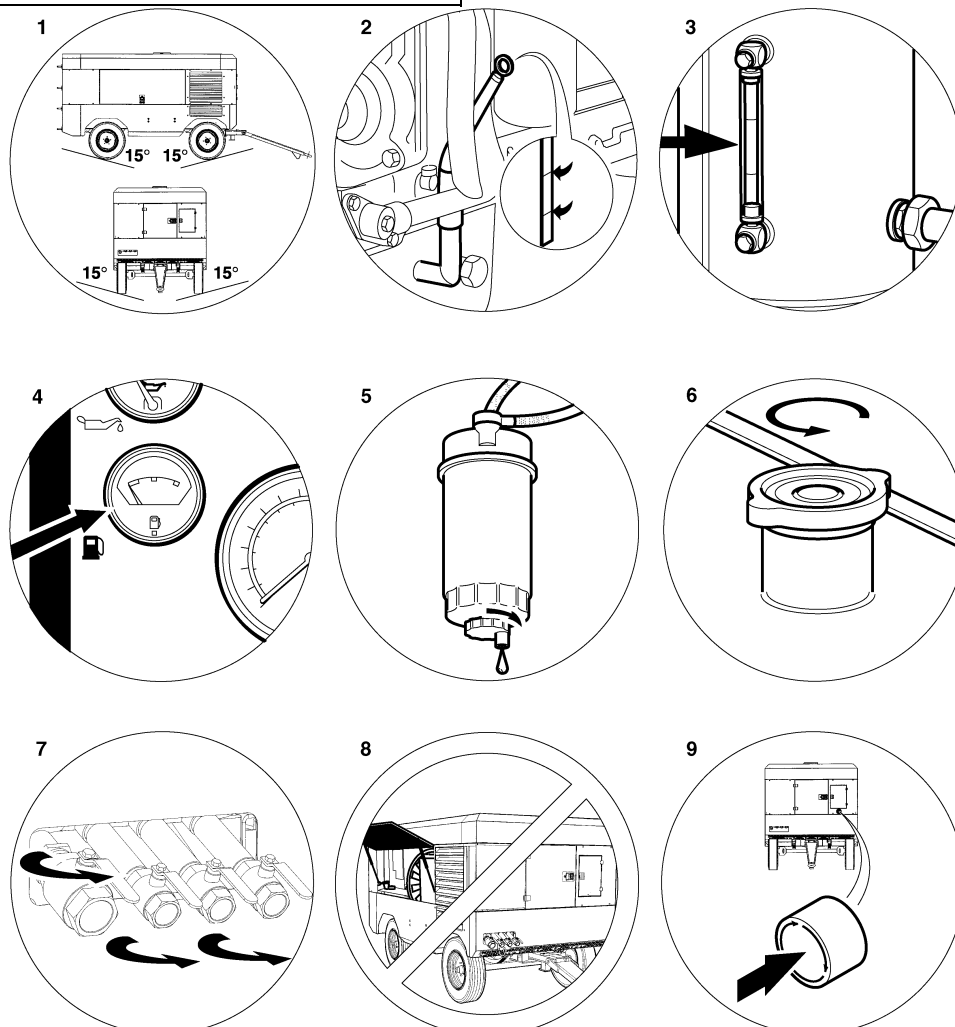

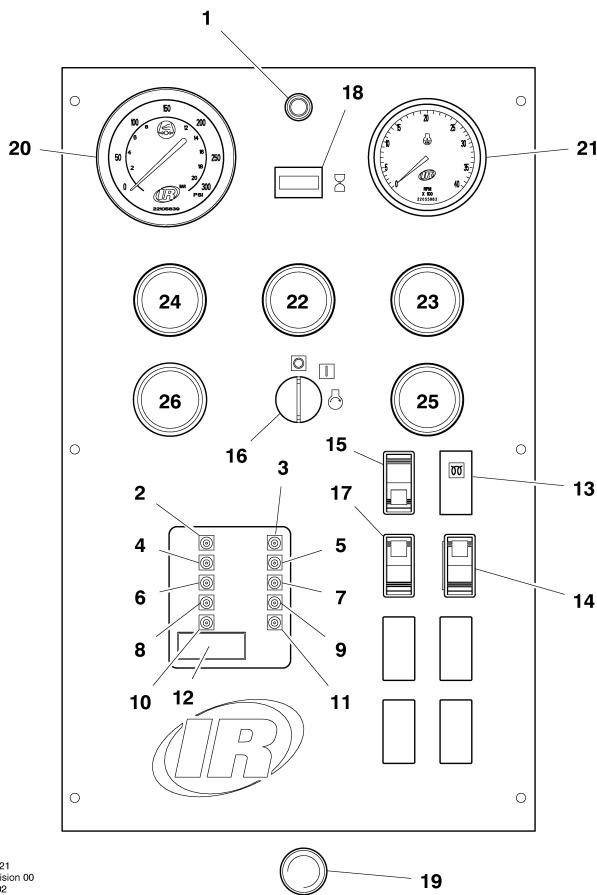

T1021
Revision 00
10/02

OPERATING CONTROLS AND INSTRUMENTS



The operating controls and instruments are arranged on the control panel as shown above. A description of each panel device is as follows:

1. **Panel Light:** Illuminates the instrument control panel controlled by Switch 14.
2. **High Compressor Temp:** Fault indicator lamp. Indicates shutdown due to high compressor temperature.
3. **Low Radiator Coolant Level:** Alarm indicator lamp. Indicates engine coolant needs service.
4. **Low Engine Oil Pressure:** Fault indicator lamp. Indicates shutdown due to low engine oil pressure.
5. **Restricted Air Filter:** Alarm indicator lamp. Indicates engine/compressor air inlet filters need service.
6. **High Engine Coolant Temp:** Fault indicator lamp. Indicates shutdown due to high engine water temperature.



7. **Restricted IQ Air Filters:** Fault indicator lamp. Indicates shutdown due to high pressure in "IQ" air filters (if equipped).
8. **Low Fuel Level:** Fault indicator lamp. Indicates shutdown due to low fuel level. Lamp blinks at low fuel warning.
9. **Compressor Malfunction:** Fault indicator lamp. Indicates shutdown due to compressor system fault. Refer to Fault Code List.
10. **Low Battery Voltage:** Alarm indicator lamp. Indicates battery or charging system requires service.
11. **Engine Malfunction:** Engine Fault code. Refer to service card or engine manual for codes and service requirements.
12. **Malfunction Code (4 Digit):** Compressor or engine fault. Refer to manual for list of codes and service requirements.
13. **Inlet Heater / Wait to Start Lamp:** Indicates engine manifold pre heater is energized. Wait until lamp extinguishes before engaging starter.
14. **Panel Light Switch:** Controls panel lamp # 1.
15. **Service Air Switch:** Momentary contact switch. Allows engine to warm up at low compressor pressure.
16. **ON/OFF Start Switch:** Main Power Control Switch.
17. **Heater Switch:** ON/OFF Power Switch for regulation and IQ heaters. Prevents freeze up in cold weather.
18. **Hourmeter:** Indicates machine operating hours.
19. **E-STOP:** Emergency Stop Push Button (ESA units only). Push to stop, turn to release.
20. **Discharge Air Pressure Gage:** Indicates pressure in receiver tank, normally from 0 psi(kPa) to the rated pressure of the machine.
21. **Engine Tachometer:** Indicates engine speed in RPM from 0 when stopped to full speed.
22. **Fuel Level Gage:** Indicate fuel level in tank.
23. **Engine Water Temp Gage**
24. **Compressor Oil Temp Gage**
25. **Engine Oil Pressure Gage**
26. **Battery Voltage Gage**

Wedge Diagnostic Display Codes

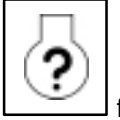

If the  fault indicator lamp is illuminated, refer to the  Alert/Shutdown list below.

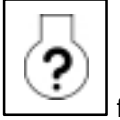

If the  fault indicator lamp is illuminated, refer to the  Engine diagnostic list below.



ALERT/SHUTDOWN CONDITIONS Version: 1.40

	ALERT		SHUTDOWN		
	CODE	LIGHT BLINKS	CODE	LIGHT STEADY	DELAY (sec)
Engine Speed < Min. RPM			1	CPRSR Malfunction.	30
Engine Speed > Max. RPM			2	CPRSR Malfunction.	30
Engine Crank Time Exceeded			3	CPRSR Malfunction.	0
Engine Oil Temperature > 252 deg. F	5	CPRSR Malfunction.			
Intake Manifold Temperature > 180 deg. F	6	CPRSR Malfunction.			
Water In Fuel	8	CPRSR Malfunction.			
Engine Not Responding To Throttle command	10	CPRSR Malfunction.			
Engine Shut Itself Down: reason unknown	29	CPRSR Malfunction.			
Low AE Oil Pressure (HP 1600 Only)			31	CPRSR Malfunction.	20
Disch. Temp (RT2) Sensor Fault			32	CPRSR Malfunction.	10
Sep. Tank Pressure (PT1) Sensor Fault	33	CPRSR Malfunction.			
Seperator Tank Pressure >20 PSI During Start Attempt (Engine Will Not Crank)			34	CPRSR Malfunction.	0
Machine Over Pressure			35	CPRSR Malfunction.	1
Safety Valve Open			36	CPRSR Malfunction.	2

	ALERT		SHUTDOWN		
	CODE	LIGHT BLINKS	CODE	LIGHT STEADY	DELAY (sec)
Seperator Tank Temp > (247 deg.F)			50	CPRSR Malfunction.	3
Machine ID Not Valid			51	CPRSR Malfunction.	0
Sep. Tank Temp (RT1) Sensor Fault			53	CPRSR Malfunction.	10
Reg. System Pressure (PT2) Sensor Fault	54	CPRSR Malfunction.			
Estop Button Pushed	55	CPRSR Malfunction.	55	CPRSR Malfunction.	3
Minimum Pressure Not Met	56	CPRSR Malfunction.			
Engine Not Going To Max RPM Prior To Load	57	CPRSR Malfunction.			
Serial Comm. Problem	70	CPRSR Malfunction.			
CAN Bus Problem	71	CPRSR Malfunction.			
Dedicated Lights:					
Low Fuel Level		Fuel Level		Fuel Level	3
Air Filter Restriction		Soiled Filter			
Low Battery Voltage		Battery Charging Condition			
Engine Oil Pressure <18 PSI		Low Engine Oil Pressure			
Low Coolant Level		Engine Coolant Level			
Engine Coolant Temperature > = 215 deg. F		High Engine Temp.			
Engine Coolant Temperature > = 220 deg. F				High Engine Temp.	10
IQ Filter Restriction				IQ Filt. Rest	3
High Discharge Temp. (RT2>247 deg. F)				High Comp Temp.	3

IR ENGINE MODEL 6IRQ9AE

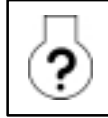

ENGINE DIAGNOSTIC CODES

Displayed Code	FMI*	Definition
111	12	Engine Control Module – Critical internal failure
115	2	Engine Speed/Position Sensor Circuit – lost both of two signals from the magnetic pickup sensor
121	10	Engine Speed/Position Sensor Circuit – lost one of two signals from the magnetic pickup sensor
122	3	Intake Manifold Pressure Sensor #1 Circuit – shorted high
123	4	Intake Manifold Pressure Sensor #1 Circuit – shorted low
131	3	Accelerator Pedal Position Sensor Circuit – shorted high
132	4	Accelerator Pedal Position Sensor Circuit – shorted low
133	3	Remote Accelerator Pedal Position Sensor Circuit – shorted high
134	4	Remote Accelerator Pedal Position Sensor Circuit – shorted high
135	3	Engine Oil Pressure Sensor Circuit – shorted high
141	4	Engine Oil Pressure Sensor Circuit – shorted low
143	18	Engine Oil Pressure Low – Warning
144	3	Engine Coolant Temperature Sensor Circuit – shorted high
145	4	Engine Coolant Temperature Sensor Circuit – shorted low
146	16	Engine Coolant Temperature High – Warning
147	8	Accelerator Pedal Position Sensor Circuit – low frequency
148	8	Accelerator Pedal Position Sensor Circuit – high frequency
151	0	Engine Coolant Temperature High – Critical
153	3	Intake Manifold Temperature Sensor #1 Circuit – shorted high
154	4	Intake Manifold Temperature Sensor #1 Circuit – shorted low
155	0	Intake Manifold Temperature #1 High – Critical
184	2	Engine Control Module Identification Input State Error
211	11	Additional OEM/Vehicle Diagnostic Codes have been logged. Check other ECM's for DTC's.
221	3	Ambient Air Pressure Sensor Circuit – shorted high
222	4	Ambient Air Pressure Sensor Circuit – shorted low
234	0	Engine Speed High – Critical
235	1	Engine Coolant Level Low – Critical
241	2	Vehicle Speed Sensor Circuit – data incorrect
242	10	Vehicle Speed Sensor Circuit – tampering has been detected
243	4	Engine Brake Driver #1 Circuit – shorted low
245	4	Fan Clutch Circuit – shorted low
263	3	Fuel Temperature Sensor Circuit – shorted high
265	4	Fuel Temperature Sensor Circuit – shorted low
268	2	Fuel Pressure Sensor Circuit – data incorrect
271	4	High Fuel Pressure Solenoid Valve #1 Circuit – shorted low
272	3	High Fuel Pressure Solenoid Valve #1 Circuit – shorted high
273	4	High Fuel Pressure Solenoid Valve #2 Circuit – shorted low
274	3	High Fuel Pressure Solenoid Valve #2 Circuit – shorted high
275	7	Fuel Pumping Element #1 (Front) –mechanically stuck
276	3	Fuel Injection Control Valve Circuit – shorted high

* FMI (Failure Mode Indicator) – Requires engine diagnostic tool to display.

Displayed Code	FMI*	Definition
277	7	Fuel Injection Control Valve – mechanically stuck
278	11	Fuel Priming Pump Control Circuit – shorted high/low
279	4	Fuel Injection Control Valve Circuit – shorted low
281	7	High Fuel Pressure Solenoid Valve #1 – mechanically stuck
282	7	High Fuel Pressure Solenoid Valve #2 – mechanically stuck
283	3	Engine Speed/Position Sensor #1 (Crankshaft) Supply Voltage Circuit – shorted high
284	4	Engine Speed/Position Sensor #1 (Crankshaft) Supply Voltage Circuit – shorted low
285	9	SAE J1939 Multiplexing PGN Timeout Error
286	13	SAE J1939 Multiplexing Configuration Error
287	2	SAE J1939 Multiplexing Accelerator Pedal Sensor System Error
288	19	SAE J1939 Multiplexing Remote Throttle Data Error
296	14	Auxiliary Pressure Sensor Input # 2 Engine Protection – Critical
297	3	Auxiliary Pressure Sensor Input # 2 Circuit – shorted high
298	4	Auxiliary Pressure Sensor Input # 2 Circuit – shorted low
319	2	Real Time Clock – Power Interrupt
328	7	Fuel Pumping Element #2 (Rear) – mechanically stuck
329	14	Fuel System Leakage error
349	16	Transmission Output Shaft (Tailshaft) Speed High – Warning
352	4	Sensor Supply Voltage #1 Circuit – shorted low
381	11	Intake Air Heater (Relay Enable) #1 Circuit – data incorrect
382	11	Intake Air Heater (Relay Enable) #2 Circuit – data incorrect
385	3	OEM Sensor Supply Voltage Circuit – shorted high
386	3	Sensor Supply Voltage #1 Circuit – shorted high
387	3	Accelerator Pedal Position Sensor Supply Voltage Circuit – shorted high
415	1	Engine Oil Pressure Low – Critical
418	15	Water in Fuel Indicator High – Maintenance
422	2	Engine Coolant Level Sensor Circuit – data incorrect
429	4	Water in Fuel Sensor Circuit – shorted low
431	2	Accelerator Pedal Idle Validation Circuit – data incorrect
432	13	Accelerator Pedal Idle Validation Circuit – out of calibration
433	2	Intake Manifold Pressure Sensor Circuit – data incorrect
434	2	Power Lost without Ignition Off
441	18	Battery #1 Voltage Low – Warning
442	0	Battery #1 Voltage High – Warning
443	4	Accelerator Pedal Position Sensor Supply Voltage Circuit – shorted low
444	18	OEM Sensor Supply Voltage Low – Warning
449	16	Fuel Pressure High – Warning

* FMI (Failure Mode Indicator) – Requires engine diagnostic tool to display.

Displayed Code	FMI*	Definition
451	3	Injector Metering Rail #1 Pressure Sensor Circuit – shorted high
452	4	Injector Metering Rail #1 Pressure Sensor Circuit – shorted low
488	0	Intake Manifold Temperature High – Warning
489	1	Transmission Output Shaft (Tailshaft) Speed Low – Warning
493	13	Fuel Pump Calibration Trim Circuit Error
497	2	Multiple Unit Synchronization Switch Circuit – data incorrect
515	3	Accelerator Pedal Frequency Position Sensor Supply Circuit – shorted high
516	4	Accelerator Pedal Frequency Position Sensor Supply Circuit – shorted low
524	2	OEM Alternate Droop Switch Validation – data incorrect
527	3	Auxiliary Input/Output #2 Circuit – shorted high
528	2	OEM Alternate torque validation switch – data incorrect
529	3	Auxiliary Input/Output #3 Circuit – shorted high
539	11	Injector Control Valve Electronic Filter (Transorb) Error
551	4	Accelerator Pedal Idle Validation Circuit – shorted low
599	14	OEM Commanded Dual Output Shutdown
611	31	Engine Hot Shutdown

* FMI (Failure Mode Indicator) – Requires engine diagnostic tool to display.

STARTING THE MACHINE

Ensure emergency stop button is reset.

WARNING: Under no circumstances should volatile fluids such as ether be used for starting this machine.

All normal starting functions are incorporated in the key operated switch.

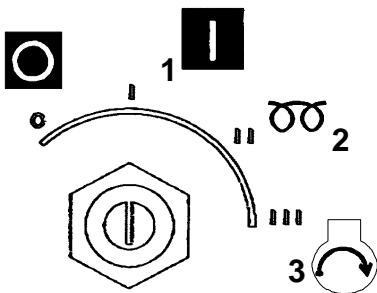

Turn the keyswitch to position 1;

- The auxiliary start compressor will operate to close the inlet valve.
- The wedge controller will execute a lamp test.
- The low engine oil pressure and low battery lamps will flash indicating proper communication between wedge and engine ECM.

Inlet heater / Wait to start light

- Turn the key switch to on position 1 until the inlet heater warning light 13 extinguishes.

NOTE: Position 2 is not used

- Turn the key switch to crank position 3 (engine start position).
- Release to on position 1 when the engine starts. The engine will now be running at a reduced speed.
- During warm up, the engine will idle at 1500RPM. After warm up the engine will idle at a lower speed.

NOTE: In order to allow the machine to start at a reduced load, a valve, which is operated by a service air switch located on the instrument panel, is incorporated in the regulation system. (The valve automatically returns to the start position when the machine is switched off and air pressure relieved from the system).

- Allow the engine to reach its operating temperature – then press the pressure control button 15.
- At this point in the operation of the machine it is safe to apply *full load* to the engine.

CAUTION: If the engine does not start, repeat the above procedure after waiting for a minimum of one minute.

If the engine fails to start, refer to the *MAINTENANCE* section of this manual, and to the *ENGINE MANUFACTURER'S MANUAL*.

STOPPING THE MACHINE

- Close the service valve.
- Allow the machine to run unloaded for a short period of time to reduce the engine temperature.
- Turn the ON/OFF start switch to the 0 (off) position.

NOTE: As soon as the engine stops, the automatic blowdown valve will relieve all pressure from the system, except for the discharge pipe / manifold area. This area should be depressurised by opening the discharge valve, keeping clear of any airflow from it.

If the automatic blowdown valve fails to operate, then pressure must be relieved from the system by means of the service valve(s).

WARNING: When relieving system pressure by means of the service valve(s), a small amount of pressure will remain in the system. No maintenance work should be carried out whilst this situation exists. This pressure may be relieved by *slowly* operating the manual *blowdown* valve.

CAUTION: Never allow the machine to stand idle with pressure in the system.

EMERGENCY STOPPING

In the event that the unit has to be stopped in an emergency, **PRESS THE EMERGENCY STOP SWITCH ON THE FRONT OF THE MACHINE AND ENSURE THAT IT ENGAGES IN DEPRESSED POSITION. (IF FITTED)**

If the unit is not fitted with an emergency stop switch, rotate the start switch to the (0) off position.

RE-STARTING AFTER AN EMERGENCY

Disengage emergency stop control from engaged (depressed) position. (IF FITTED)

If the machine has been switched off because of a machine malfunction, then identify and correct the fault before attempting to re-start.

If the machine has been switched off for reasons of safety, then ensure that the machine can be operated safely before re-starting.

Refer to the *PRIOR TO STARTING* and *STARTING THE UNIT* instructions earlier in this section before re-starting the machine.

MONITORING DURING OPERATION

Should any of the safety shut-down conditions occur, the unit will stop.

Refer to the wedge diagnostic display codes table for a listing of shutdown conditions.

CAUTION: To ensure an adequate flow of oil to the compressor at low temperature, never allow the discharge pressure to fall below 3,5 bar.

DECOMMISSIONING

When the machine is to be permanently decommissioned or dismantled, it is important to ensure that all hazard risks are either eliminated or notified to the recipient of the machine. In particular:–

- . Do not destroy batteries or components containing asbestos without containing the materials safely.
- . Do not dispose of any pressure vessel that is not clearly marked with its relevant data plate information or rendered unusable by drilling, cutting etc.
- . Do not allow lubricants or coolants to be released into land surfaces or drains.
- . Do not dispose of a complete machine without documentation relating to instructions for its use.

MAINTENANCE							
	Initial 500 miles /850 km	Daily	Weekly	Monthly	3 Monthly. 500 hrs.	6 Monthly. 1000 hrs	12 Monthly. 2000 hrs
Compressor Oil Level		C					
Engine Oil Level		C					
*Radiator Coolant Level		C					
Gauges/Lamps		C					
*Air Cleaner Service Indicators		C					
Fuel Tank (Fill at end of day)		C				D	
*Fuel/Water Separator Drain		C					
Oil Leaks		C					
Fuel Leaks		C					
Drain Water From Fuel Filters		D					
Coolant Leaks		C					
Radiator Filler Cap		C					
Air Cleaner Precleaner Dumps			C				
Fan/Alternator Belts			C				
Battery Connections/Electrolyte			C				
Tire Pressure and Surface			C				
*Wheel Lug Nuts				C			
Hoses (Oil, Air, Intake, etc.)				C			
Automatic Shutdown System				C			
Air Cleaner System				C			
Compressor heat exchanger exterior				C			
* Engine heat exchanger exterior				C			
Fasteners, Guards					C		
Air Cleaner Elements						R/WI	

*Disregard if not appropriate for this particular machine.

(1) or 3000 miles/5000km whichever is the sooner

(2) or as defined by local or national legislation

C = Check (adjust, clean or replace as necessary)

CBT =check before towing.

CR = Check and report

D = Drain

G = Grease

R=Replace

T = Test

W I =or when indicated if earlier.

Refer to specific sections of the operator's manual for more information.

	Initial 500 miles /850 km	Daily	Weekly	Monthly	3 Monthly. 500 hrs.	6 Monthly. 1000 hrs	12 Monthly. 1500 hrs	12 Monthly. 2000 hrs
*Fuel/Water Separator Element					R			
Compressor Oil Filter Element					R			
Compressor Oil						R		
Engine Oil Change					R			
Engine Oil Filter					R			
*Water Pump Grease.						R		
*Wheels (Bearings, Seals, etc.)								C
*Engine Coolant						C		R
Fuel Filter Element					R			
*Injection Nozzle Check							C	
Shutdown Switch Settings								T
Scavenger Orifice & Related Parts								C
Oil Separator Element								R
*Feed Pump Strainer Cleaning.								C
*Valve Clearance Check								C
Lights (running, brake, & turn)		CBT						
Pintle Eye Bolts		CBT						
*Brakes		CBT			C			
*Brake linkage	C							
Emergency stop		T						
Fasteners		C						
Running gear linkage				G				
Safety valve					C			
Running gear bolts(1)					C			

*Disregard if not appropriate for this particular machine.

(1) or 3000 miles/5000km whichever is the sooner

(2) or as defined by local or national legislation

C = Check (adjust, clean or replace as necessary)

CBT =check before towing.

CR = Check and report

D = Drain

G = Grease

R=Replace

T = Test

W I =or when indicated if earlier.

Refer to specific sections of the operator's manual for more information.

30

MAINTENANCE

	Initial 500 miles /850 km	Daily	Weekly	Monthly	3 Monthly. 500 hrs.	6 Monthly. 1000 hrs	12 Monthly. 2000 hrs
Scavenge line						C	
Pressure system						C	
Engine breather element							C
Separator tank (2) exterior							CR
Lubricator (Fill)		C					

	2 Yrs	4 Yrs	6 Yrs				
Safety valve	C						
Hoses		R					
Separator tank (2) interior			C				

*Disregard if not appropriate for this particular machine.

(1) or 3000 miles/5000km whichever is the sooner

(2) or as defined by local or national legislation

C = Check (adjust, clean or replace as necessary)

CBT =check before towing.

CR = Check and report

D = Drain

G = Grease

R=Replace

T = Test

W I =or when indicated if earlier.

Refer to specific sections of the operator's manual for more information.

ROUTINE MAINTENANCE

This section refers to the various components which require periodic maintenance and replacement.

The *SERVICE/MAINTENANCE CHART* indicates the various components' descriptions and the intervals when maintenance has to take place. Oil capacities, etc., can be found in the *GENERAL INFORMATION* section of this manual.

For any specification or specific requirement on service or preventative maintenance for the engine, refer to the *Engine Manufacturer's Manual*.

Compressed air can be dangerous if incorrectly handled. Before doing any work on the unit, ensure that all pressure is vented from the system and that the machine cannot be started accidentally.

If the automatic blowdown fails to operate, then pressure must be gradually relieved by operating the manual blowdown valve. Suitable personal protective equipment should be worn.

Ensure that maintenance personnel are adequately trained, competent and have read the Maintenance Manuals.

Prior to attempting any maintenance work, ensure that:–

- all air pressure is fully discharged and isolated from the system. If the automatic blowdown valve is used for this purpose, then allow enough time for it to complete the operation.

NOTE: Pressure will always remain in the part of the system between the minimum pressure valve and the discharge valve after operation of the auto blowdown valve.

THIS PRESSURE MUST BE RELIEVED BY CAREFULLY:

- (a) DISCONNECTING ANY DOWNSTREAM EQUIPMENT.
 - (b) OPENING THE DISCHARGE VALVE TO ATMOSPHERE.
- (USE HEARING PROTECTION IF NECESSARY).

- the machine cannot be started accidentally or otherwise, by posting warning signs and/or fitting appropriate anti-start devices.

- all residual electrical power sources (mains and battery) are isolated.

Prior to opening or removing panels or covers to work *inside* a machine, ensure that:–

- anyone entering the machine is aware of the reduced level of protection and the additional hazards, including hot surfaces and intermittently moving parts.

- the machine cannot be started accidentally or otherwise, by posting warning signs and/or fitting appropriate anti-start devices.

Prior to attempting any maintenance work on a *running* machine, ensure that:–

- the work carried out is limited to only those tasks which require the machine to run.

- the work carried out with safety protection devices disabled or removed is limited to only those tasks which require the machine to be running with safety protection devices disabled or removed.

- all hazards present are known (e.g. pressurised components, electrically live components, removed panels, covers and guards, extreme temperatures, inflow and outflow of air, intermittently moving parts, safety valve discharge etc.).

- appropriate personal protective equipment is worn.

- loose clothing, jewellery, long hair etc. is made safe.

- warning signs indicating that *Maintenance Work is in Progress* are posted in a position that can be clearly seen.

Upon completion of maintenance tasks and prior to returning the machine into service, ensure that:–

- the machine is suitably tested.

- all guards and safety protection devices are refitted.

- all panels are replaced, canopy and doors closed.

- hazardous materials are effectively contained and disposed of.

PROTECTIVE SHUTDOWN SYSTEM

Refer to the Wedge diagnostic display codes table for a listing of shutdown conditions.

Low engine fuel level switch.

At three month intervals, test the low engine fuel level switch circuit as follows:

- Start the machine.

Note: Do not press the load button.

- Disconnect the switch, the machine should shutdown.

- Re-connect the switch.

At twelve month intervals, test the low engine fuel level switch by removing and operating the float manually.

CAUTION: Never remove or replace switches when the machine is running.

SCAVENGE LINE

The scavenge line runs from the combined orifice/drop tube in the separator tank, to the orifice fitting located in the airend.

Examine the orifice, check valve and hoses at every service or in the event of oil carryover into the discharge air.

It is good preventative maintenance to check that the scavenge line and tube are clear of any obstruction each time the compressor lubricant is changed as any blockage will result in oil carryover into the discharge air.

COMPRESSOR OIL FILTER

Refer to the *MAINTENANCE CHART* in this section for the recommended servicing intervals.

Removal

WARNING: Do not remove the filter(s) without first making sure that the machine is stopped and the system has been completely relieved of all air pressure. (Refer to *STOPPING THE UNIT* in the *OPERATING INSTRUCTIONS* section of this manual).

Clean the exterior of the filter housing and remove the *spin-on* element by turning it in a counter-clockwise direction.

Inspection

Examine the filter element.

CAUTION: *If there is any indication of the formation of varnishes, shellacs or lacquers on the filter element, it is a warning that the compressor lubricating and cooling oil has deteriorated and that it should be changed immediately. Refer to LUBRICATION later in this section.*

Reassembly

Clean the filter gasket contact area and install the new element by screwing in a clockwise direction until the gasket makes contact with the filter housing. Tighten a further $1/2$ to $3/4$ of a revolution.

CAUTION: *Start the machine (refer to PRIOR TO STARTING and STARTING THE UNIT in the OPERATING INSTRUCTIONS section of this manual) and check for leakage before the machine is put back into service.*

COMPRESSOR OIL SEPARATOR ELEMENT

Refer to the *SERVICE / MAINTENANCE CHART* in this section for service intervals.

Removal

WARNING: *Do not remove the filter(s) without first making sure that the machine is stopped and the system has been completely relieved of all air pressure. (Refer to STOPPING THE UNIT in the OPERATING INSTRUCTIONS section of this manual).*

Disconnect all hoses and tubes from the separator tank cover plate. Remove the drop-tube from the separator tank cover plate and then remove the cover plate. Remove the separator element.

Inspection

Examine the filter element. Examine all hoses and tubes, and replace if necessary.

Reassembly

Thoroughly clean the orifice/drop tube and filter gasket contact area before reassembly. Install the new element.

WARNING
Do not remove the staple from the anti-static gasket on the separator element since it serves to ground any possible static build-up. Do not use gasket sealant since this will affect electrical conductance.

Reposition the cover plate, taking care not to damage the gasket, and replace the cover plate screws tightening in a *criss-cross* pattern to the recommended torque (refer to the *TORQUE SETTING TABLE* later in this section).

Replace the drop-tube and reconnect all hoses and tubes to the separator tank cover plate.

Replace the compressor oil (refer to *LUBRICATION* later in this section).

CAUTION: *Start the machine (refer to PRIOR TO STARTING and STARTING THE UNIT in the OPERATING INSTRUCTIONS section of this manual) and check for leakage before the machine is put back into service.*

COMPRESSOR OIL COOLER AND ENGINE RADIATOR AIR CHARGE COOLER

When grease, oil and dirt accumulate on the exterior surfaces of the oil cooler and radiator, the efficiency is impaired. It is recommended that each month the oil cooler and radiator be cleaned by directing a jet of compressed air, (carrying if possible a non-flammable cleaning solvent) over the exterior core of the cooler/radiator. This should remove any accumulation of oil, grease and dirt from the exterior core of the cooler so that the entire cooling area can radiate the heat of the lubricating and cooling oil/water into the air stream.

WARNING: *Hot engine coolant and steam can cause injury. When adding coolant or antifreeze solution to the engine radiator, stop the engine at least one minute prior to releasing the radiator filler cap. Using a cloth to protect the hand, slowly release the filler cap, absorbing any released fluid with the cloth. Do not remove the filler cap until all excess fluid is released and the engine cooling system fully depressurised.*

WARNING: *Follow the instructions provided by the antifreeze supplier when adding or draining the antifreeze solution. It is advisable to wear personal protective equipment to prevent skin and eye contact with the antifreeze solution.*

AIR FILTER ELEMENT

The air filter should be inspected regularly (refer to the *SERVICE/MAINTENANCE CHART*) and the element replaced when the restriction indicator lamp illuminates. The dust collector box(es) should be cleaned daily (more frequently in dusty operating conditions) and not allowed to become more than half full.

The safety element should be renewed every 3000 hours or every third change of the main element, whichever comes first.

Removal

CAUTION: *Never remove and replace element(s) when the machine is running.*

Clean the exterior of the filter housing and remove the filter element by releasing the nut.

If the safety element is to be renewed, thoroughly clean the interior of the filter housing prior to removing the safety element.

Inspection

Check for cracks, holes or any other damage to the element by holding it up to a light source, or by passing a lamp inside.

CAUTION: If inspection reveals damage to the main element, the safety element **must** be replaced.

Check the seal at the end of the element and replace if any sign of damage is evident.

Reassembly

Assemble the new element into the filter housing ensuring that the seal seats properly.

Secure the element in the housing by hand tightening the nut.

Assemble the dust collector box parts, ensuring that they are correctly positioned.

Before restarting the machine, check that all clamps are tight.

NOTE: In the event that a new filter element is not readily available, the element can be re-used after cleaning. In this case the following procedure must be carried out:

Clean the element by directing a jet of clean, dry compressed air, no more than 5 bar, at an angle of 45 degrees to the outside of the element. Carefully blow any dust from each fold of the element.

Compressed air cleaning is only recommended when a new element is not available.

CAUTION: Safety elements must not be cleaned and re-used.

VENTILATION

Always check that the air inlets and outlets are clear of debris etc.

CAUTION: NEVER clean by blowing air inwards.

COOLING FAN DRIVE

Periodically check that the fan mounting bolt in the fan hub has not loosened. If, for any reason, it becomes necessary to remove the fan or re-tighten the fan mounting bolt, apply a good grade of commercially available thread locking compound to the bolt threads and tighten to the torque value shown in the *TORQUE SETTING TABLE* later in this section.

The fan belt(s) should be checked regularly for wear and correct tensioning.

FUEL SYSTEM

The fuel tank should be filled daily or every eight hours. To minimise condensation in the fuel tank(s), it is advisable to top up after the machine is shut down or at the end of each working day. At six month intervals drain any sediment or condensate that may have accumulated in the tank(s).

FUEL FILTER WATER SEPARATOR

The fuel filter water separator contains a filter element which should be replaced at regular intervals (see the *SERVICE/MAINTENANCE CHART*).

CHARGE COOLER PIPEWORK:-

Inspect all hoses and clips on the charge cooler pipe work.

Engine damage will occur if the charge cooling system leaks.

HOSES

All components of the engine cooling air intake system should be checked periodically to keep the engine at peak efficiency.

At the recommended intervals, (see the *SERVICE/MAINTENANCE CHART*), inspect all of the intake lines to the air filter, and all flexible hoses used for air lines, oil lines and fuel lines.

Periodically inspect all pipework for cracks, leaks, etc. and replace immediately if damaged.

ELECTRICAL SYSTEM

WARNING: Always disconnect the battery cables before performing any maintenance or service.

Inspect the safety shutdown system switches and the instrument panel relay contacts for evidence of arcing and pitting. Clean where necessary.

Check the mechanical action of the components.

Check the security of electrical terminals on the switches and relays i.e. nuts or screws loose, which may cause local hot spot oxidation.

Inspect the components and wiring for signs of overheating i.e. discolouration, charring of cables, deformation of parts, acrid smells and blistered paint.

BATTERY

Keep the battery terminals and cable clamps clean and lightly coated with petroleum jelly to prevent corrosion.

The retaining clamp should be kept tight enough to prevent the battery from moving.

PRESSURE SYSTEM

At 3 month intervals it is necessary to inspect the external surfaces of the system (from the airtank through to the discharge valve(s)) including hoses, tubes, tube fittings and the separator tank, for visible signs of impact damage, excessive corrosion, abrasion, tightness and chafing. Any suspect parts should be replaced before the machine is put back into service.

TYRES/TYRE PRESSURE

See the *GENERAL INFORMATION* section of this manual.

RUNNING GEAR/WHEELS

Check the wheel nut torque 20 miles (30 kilometres) after refitting the wheels. Refer to the *TORQUE SETTING TABLE* later in this section.

The bolts securing the running gear to the chassis should be checked periodically for tightness (refer to the *SERVICE/MAINTENANCE CHART* for frequency) and re-tightened where necessary. Refer to the *TORQUE SETTING TABLE* later in this section.

LUBRICATION

The engine is initially supplied with engine oil sufficient for a nominal period of operation (for more information, consult The *Engine Manufacturer's Manual*).

CAUTION: Always check the oil levels before a new machine is put into service.

If, for any reason, the unit has been drained, it must be re-filled with new oil before it is put into operation.

ENGINE LUBRICATING OIL

The engine oil should be changed at the engine manufacturer's recommended intervals. Refer to the *SERVICE / MAINTENANCE CHART*.

ENGINE LUBRICATING OIL SPECIFICATION

Refer to the *Engine Manufacturer's Manual or Lubrication Specification list*.

ENGINE OIL FILTER ELEMENT

The engine oil filter element should be changed at the engine manufacturer's recommended intervals. Refer to the *SERVICE / MAINTENANCE CHART*.

COMPRESSOR LUBRICATING OIL

Refer to the *SERVICE/MAINTENANCE CHART* in this section for service intervals.

NOTE: If the machine has been operating under adverse conditions, or has suffered long shutdown periods, then more frequent service intervals will be required.

WARNING: DO NOT, under any circumstances, remove any drain plugs or the oil filler plug from the compressor lubricating and cooling system without first making sure that the machine is stopped and the system has been completely relieved of all air pressure (refer to STOPPING THE UNIT in the OPERATING INSTRUCTIONS section of this manual).

Completely drain the receiver/separator system including the piping and oil cooler by removing the drain plug(s) and collecting the used oil in a suitable container.

Replace the drain plug(s) ensuring that each one is secure.

NOTE: If the oil is drained immediately after the machine has been running, then most of the sediment will be in suspension and will therefore drain more readily.

CAUTION: Some oil mixtures are incompatible and result in the formation of varnishes, shellacs or lacquers which may be insoluble.

NOTE: Always specify INGERSOLL-RAND Pro-Tec™ oil for use at all ambient temperatures above -23°C.

RUNNING GEAR WHEEL BEARINGS

Wheel bearings should be packed with grease every 6 months. The type of grease used should conform to specification *MIL-G-10924*.

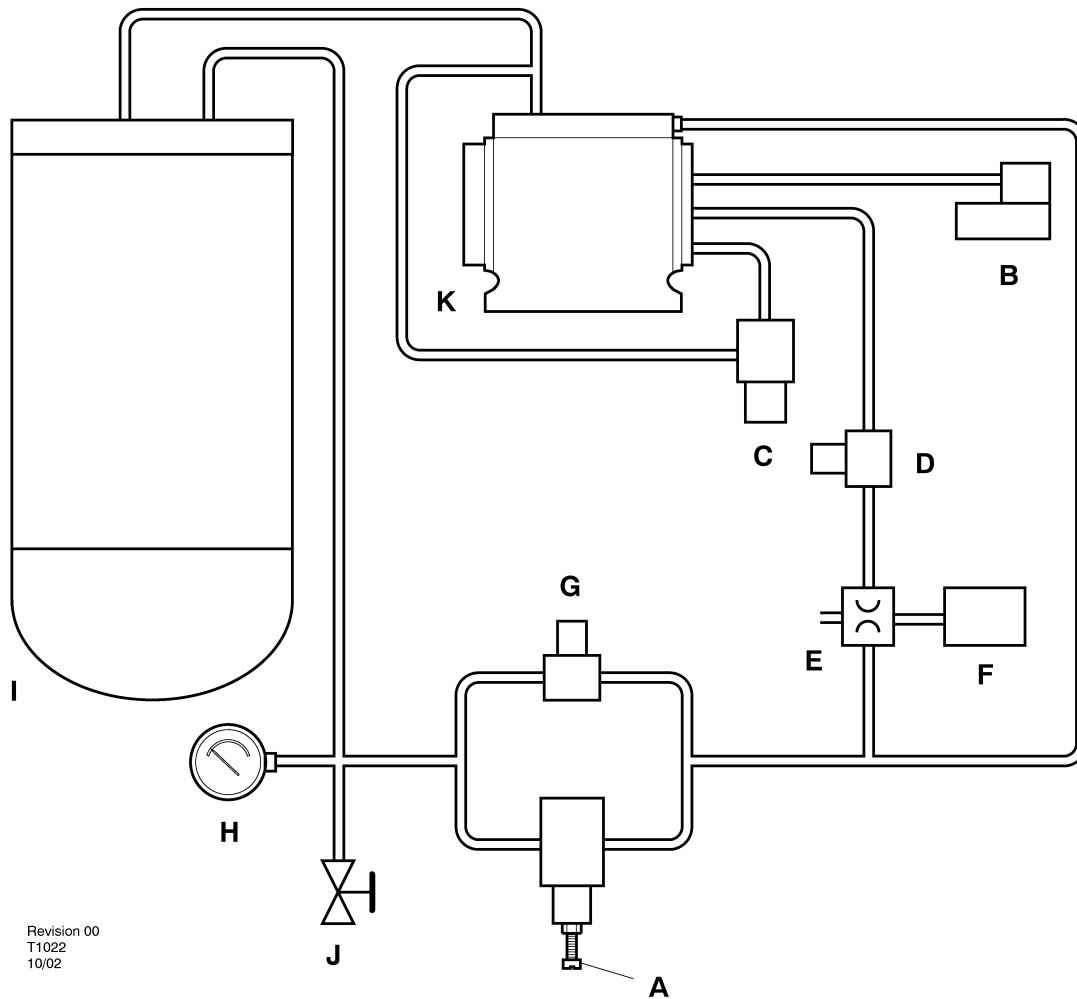

Revision 00
T11022
10/02

9/230 9/230HA 9/270 9/270HA 9/300 9/300HA 12/235 12/235HA

KEY

A Adjusting screw	E Orifice	I Separator tank
B Mini compressor	F Regulation pressure transducer	J Manual blowdown valve
C Auto blowdown valve	G Start/Run solenoid	K Unloader
D Unloader solenoid	H Panel pressure gauge	

SPEED AND PRESSURE REGULATION ADJUSTMENT

Normally, regulation requires no adjusting, but if correct adjustment is lost, proceed as follows:

Refer to the diagram above.

A: Adjusting screw

Start the machine (Refer to *STARTING INSTRUCTIONS* in the *OPERATING INSTRUCTIONS* section of this manual).

Adjust the service valve on the outside of the machine to maintain normal operating discharge pressure (refer to *GENERAL INFORMATION*) and full speed position. If the tachometer moves away from the full speed position before normal operating discharge pressure is attained, then turn the adjusting screw 'A' clockwise to increase the pressure. Optimum adjustment is achieved when the throttle just moves from its full speed position and the pressure increases slightly.

Close the service valve. The engine will slow to idle speed.

CAUTION: Never allow the idle pressure to exceed maximum allowable pressure (refer to *GENERAL INFORMATION*).

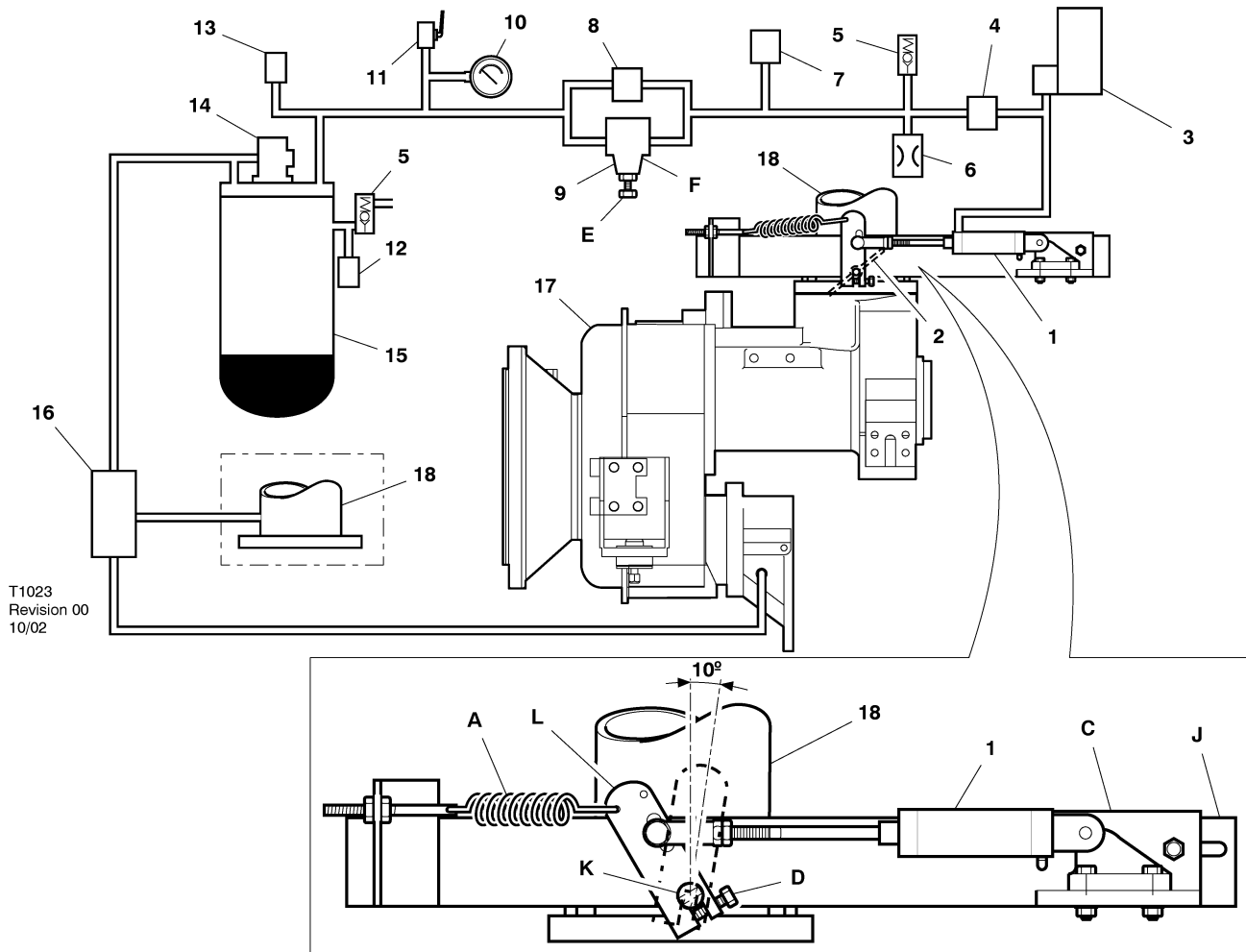

T1023
Revision 00
10/02

17/235 21/215 XHP750

KEY

1	Air cylinder	7	Regulation pressure transducer	13	Pressure transducer
2	Butterfly valve	8	Start/Run solenoid	14	Minimum pressure valve
3	Mini compressor	9	Pressure regulator	15	Separator tank
4	Unloader Solenoid	10	Panel pressure gauge	16	Auto blowdown valve
5	Relief valve	11	Manual blowdown valve	17	HR2 Airend
6	Orifice	12	Temperature sensor	18	Air inlet

SPEED AND PRESSURE REGULATION ADJUSTMENT 17/235 21/215 RHP750

Normally, regulation requires no adjusting, but if correct adjustment is lost, proceed as follows:

Refer to the diagram above.

With the unit stopped, disconnect ballast spring 'A' from the butterfly lever. Loosen the two screws securing bracket 'C' to main bracket 'J'.

Loosen screw 'D' and rotate the butterfly valve pivot shaft 'K' fully clockwise until the valve is closed. Position lever 'L' approximately 10° after vertical and tighten screw 'D'.

Keep the butterfly lever in the closed position and with the the air cylinder fully contracted tighten the screws holding bracket 'C' to the main bracket 'J'.

Allow the cylinder to return to its extended position and reconnect the ballast spring 'A'.

IMPORTANT: Ensure all components are aligned and move freely.

Start engine: Note receiver pressure. Warm up pressure should be 3,5–5,0 bar (50–70 p.s.i.).

To increase the warm up pressure, turn the air cylinder rod in an anti-clockwise direction to open the butterfly valve.

To reduce warm up pressure, turn air cylinder rod in clockwise direction to close butterfly valve.

When the engine is warmed up, press the service air switch on the control panel to commence normal regulation.

Set pressure by adjusting the screw 'E' on the pressure regulator 'F'. Turn the screw clockwise to increase pressure and anticlockwise to reduce pressure.

TORQUE VALUES

TABLE 1 INCH FASTENERS

CAPSCREW OR NUT THREAD SIZE AND PITCH	NOMINAL DESIGN TORQUE			
	8AE J249 GRADE 5 (HEAD MARKING)		8AE J249 GRADE 8 (HEAD MARKING)	
	(Nm.)	(FT-LBF)	(Nm.)	(FT-LBF)
1/4 – 20	11	8	16	12
5/16 – 18	24	17	33	25
3/8 – 16	42	31	59	44
7/16 – 14	67	49	95	70
1/2 – 13	102	75	144	106
9/16 – 12	148	109	208	154
5/8 – 11	203	150	287	212
3/4 – 10	361	266	509	376

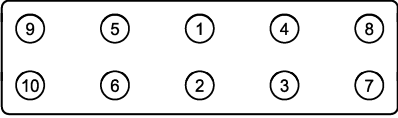

TYPICAL RECTANGULAR TORQUE PATTERN

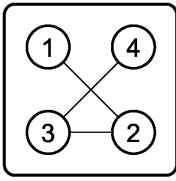

TYPICAL SQUARE TORQUE PATTERN

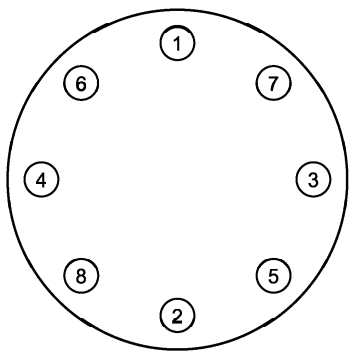

TYPICAL CIRCULAR TORQUE PATTERN

TABLE 2 METRIC FASTENERS

CAPSCREW OR NUT THREAD SIZE AND PITCH	NOMINAL DESIGN TORQUE					
	PROPERTY GRADE 8.8 (HEAD MARKING)		PROPERTY GRADE 10.9 (HEAD MARKING)		PROPERTY GRADE 12.9 (HEAD MARKING)	
	(Nm.)	(FT-LBF)	(Nm.)	(FT-LBF)	(Nm.)	(FT-LBF)
M6 X 1.0	11	8	15	11	18	13
M8 X 1.25	26	19	36	27	43	31
M10 X 1.5	52	38	72	53	84	62
M12 X 1.75	91	67	126	93	147	109
M14 X 2	145	107	200	148	234	173
M16 X 2	226	166	313	231	365	270
M20 X 2.5	441	325	610	450	713	526

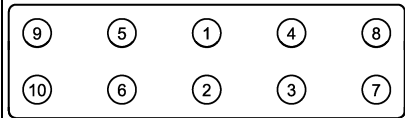

TYPICAL RECTANGULAR TORQUE PATTERN

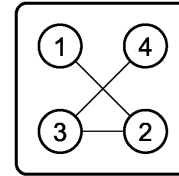

TYPICAL SQUARE TORQUE PATTERN

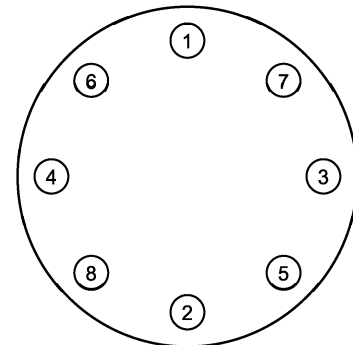

TYPICAL CIRCULAR TORQUE PATTERN

COMPRESSOR LUBRICATION

Portable Compressor Fluid Chart

Refer to these charts for correct compressor fluid required. Note that the selection of fluid is dependent on the design operating pressure of the machine and the ambient temperature expected to be encountered before the next oil change.

Design Operating Pressure	Ambient Temperature	Specification
100 psi to 300 psi	-10°F to 125°F (-23°C to 52°C)	IR Pro-Tec™ Mil -PRF 2104G SAE 10W
100 psi to 300 psi	-40°F to 125°F (-40°C to 52°C)	IR Performance 500 Mil-L-46167
350 psi	-10°F to 125°F (-23°C to 52°C) 65°F to 125°F (18°C to 52°C) -40°F to 65°F (-40°C to 18°C)	IR XHP 505 IR XHP1001 IR Performance 500 Mil-L-46167
500 psi	50°F to 125°F (10°C to 52°C) 10°F to 65°F (-12°C to 18°C) below 10°F (-12°C)	IR XHP1001 IR XHP 505 Consult Factory

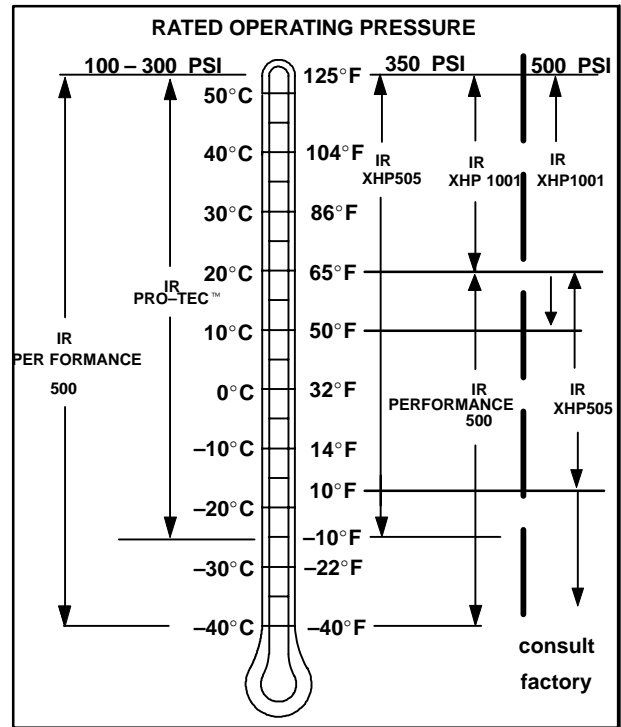

Recommended Ingersoll-Rand Fluids – Use of these fluids with original IR filters can extend airend warranty. Refer to operator's manual warranty section for details or contact your IR representative.

Compressor Recommended Fluid	1 Gal.	5 Gal.	55 Gal.	275 Gal. Tote	Europe	
					20 Litre	208 Litre
Pro-Tec™	36899698	36899706	36899714	36899722	89292973	89292981
XHP 505	NA	54418835	54418843	54418827	—	—
Performance 500	35382928	35382936	35382944	NA	—	—
XHP1001	NA	35612738	35300516	NA	—	—
Engine Oil	54480918	36875938	36866903	NA	89311716	89311724

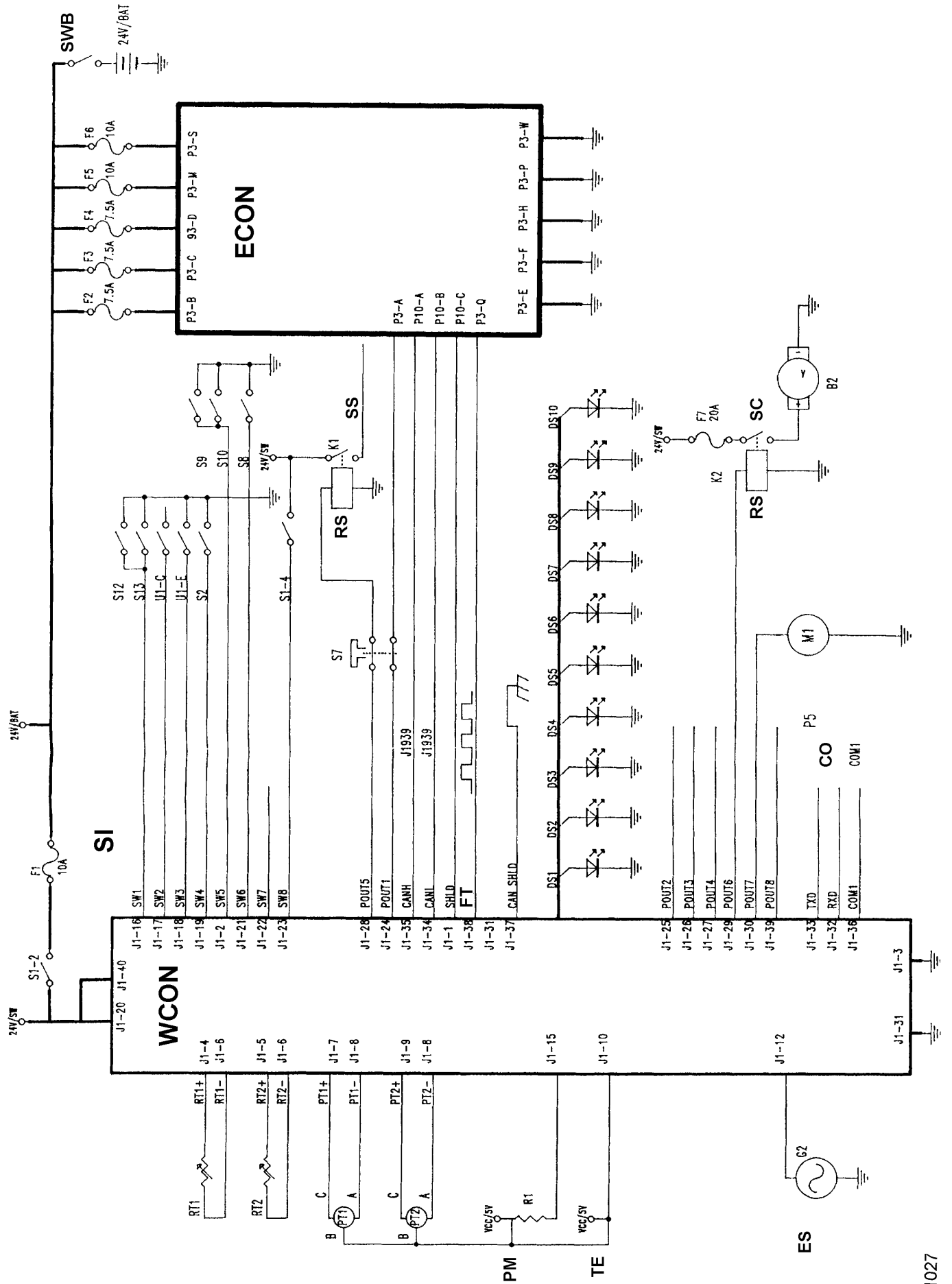

KEY

BAT	Battery	PT1	Pressure transducer, separator tank. 0–225 PSIG – 9/235, 9/270, 9/300, 12/235. 0–225 PSIG – HP935, VHP750, MHP825, XP1060. 0–500 PSIG – 21/215, 17/235, XHP750.
CO	RS232C comms	PT2	Pressure transducer, regulation system 0–100 PSIG
DS1	LED, high airtend temperature	PM	Plug, machine ID
DS2	LED, low engine oil pressure	RS	Relay–spst
DS3	LED, high engine temperature	RT1	Thermistor, separator tank temperature –30 – 255°F
DS4	LED, low fuel	RT2	Thermistor, Thermistor, airtend discharge temperature –30 – 255°F
DS5	LED, alternator	S7	Emergency stop
DS6	LED, low coolant	SC	Start compressor
DS7	LED, air filter restriction	SI	Switch inputs
DS8	LED, IQ filter restriction	SS	Starter solenoid
DS9	LED, Engine fault	SW1	IQ filter restriction
DS10	LED, compressor fault	SW2	Alert, low fuel
ECON	Engine controller	SW3	Low fuel shutdown
ES	Engine speed	SW4	Switch, service air
FT	Frequency throttle. Range = 150Hz(1200 RPM) to 375Hz(1800 RPM) at 24VDC	SW5	Air filter rest (option)
G7	Fly wheel	SW6	Switch, airtend oil pressure (12PSI N.O.)
POUT1	Engine key switch	SW7	Spare
POUT2	Solenoid, start/run	SW8	Switch, start
POUT3	Low fuel warning beacon	SWB	Switch battery disconnect
POUT4	Spare	TE	Transducer excitation
POUT5	Start relay	WCON	Wedge controller
POUT6	Start compressor		
POUT7	Hour meter		
POUT8	Solenoid, unloader		

WEDGE TO ENGINE INTERFACE

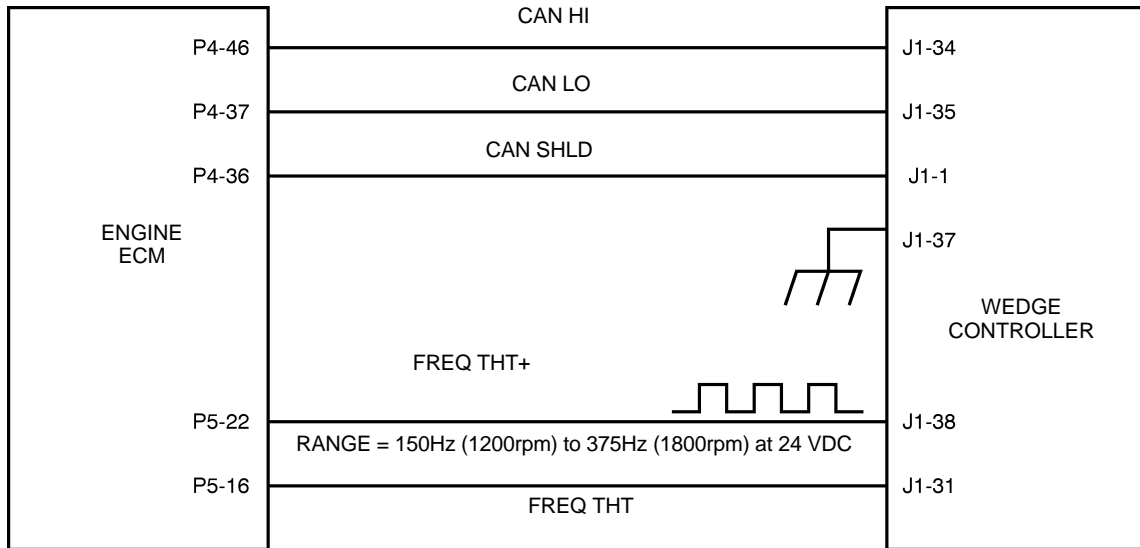

HARNESS SYSTEM SCHEMATIC

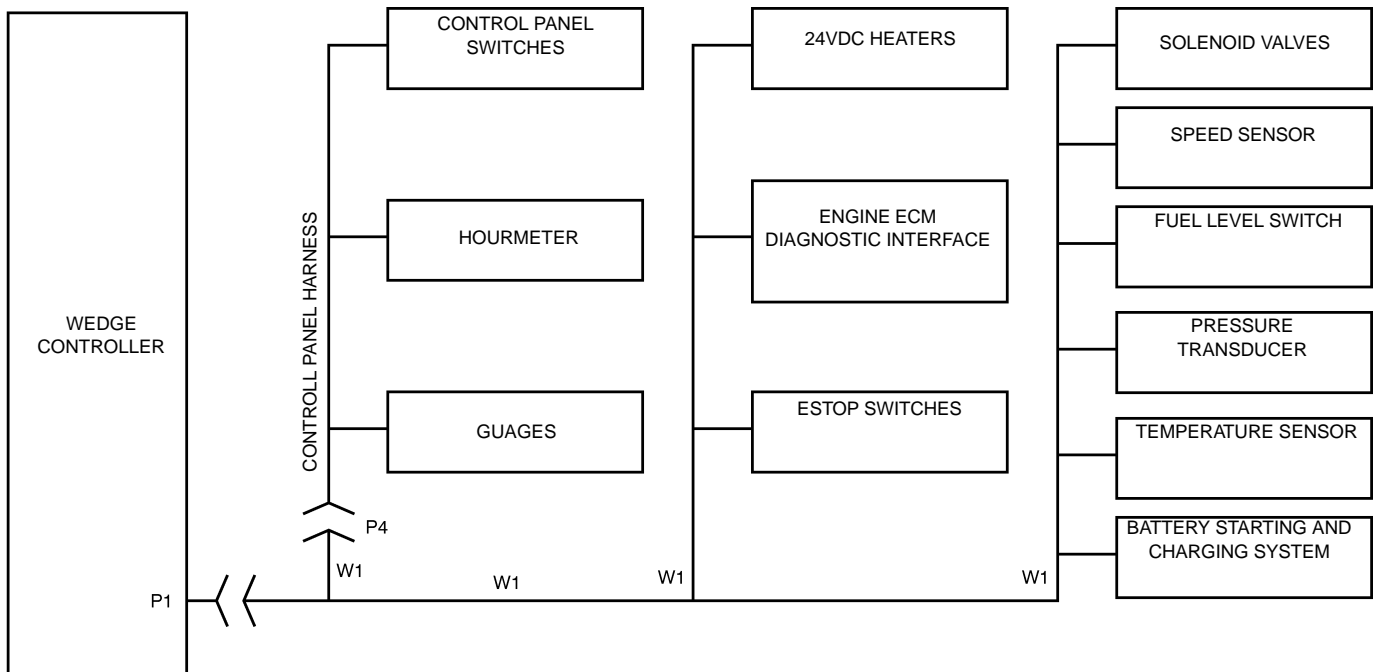

T2223
Revision 00
12/02

EMU 6IRQ9AE LOW PRESSURE ELECTRICAL PARTS 9/235, 12/235, 9/270, 9/300

PART NUMBERS	DESCRIPTION	QTY PER MACHINE
22162572	IQ HARNESS OPTION	1
36899599	IQ FILTER SWITCH	1
36899615	IQ FILTER SWITCH	1
54474572	COOLANT LEVEL SWITCH	1
36896975	SW MASTER DISCONNECT	1
36920825	0-100 PRESSURE TRANS	1
54496773	0-225 PRESSURE TRANS	1
36892362	24V SEALED RELAY	2
36785319	MAG SPEED SENSOR	1
36898922	THERMISTOR PROBE	1
36840481	SOLENOID VALVE	1
36847838	AIR FILTER RESTRICTION INDICATOR SWITCH	2
36870608	ENGINE OIL PRESSURE SENDER	1
36841138	COMPRESSOR AND ENGINE TEMPERATURE SENDER	2
36757581	COMPRESSOR OIL PRESSURE SWITCH	1
36850691	COMPRESSOR MOTOR	1
35577873	RELAY, MAGNETIC 24V K1	1
36841526	CONTROL HEATER	2
26854677	REGULATOR HEATER	1
54658323	NEGATIVE BATTERY CABLE	1
54658331	POSITIVE BATTERY CABLE	1
54511282	POSITIVE JUMPER BATTERY CABLE	1
35128982	BATTERY JUMPER	1
22132153	FRAME GROUND STRAP	1
22132153	ENGINE GROUND STRAP	1
22094759	FUEL LEVEL SENDER	1
54688411	WEDGE CONTROLLER	1
22110779	W1 CHASSIS HARNESS	1
22094650	HARNESS DIAGRAM	N/A
22101927	MACHINE ID PLUG, 1.78K OHMS	1
22101968	INLET HEATER, 120 AMPS	1
36853521	INLET HEATER RELAY	1
89303127	EMERGENCY STOP OPERATOR	1
89303135	NC E-STOP CONTACT BLOCK	2

EMU 6IRQ9AE HIGH PRESSURE ELECTRICAL PARTS 21/215, 17/235

PART NUMBERS	DESCRIPTION	QTY PER MACHINE
22162572	IQ HARNESS OPTION	1
36899599	IQ FILTER SWITCH	1
36899615	IQ FILTER SWITCH	1
54474572	COOLANT LWL SWH	1
36896975	SW MASTER DISCONNECT	1
36920825	0-100 PRESSURE TRANS	1
54765946	0-500 PRESSURE TRANS	1
36892362	24V SEALED RELAY	2
36785319	MAG SPEED SENSOR	1
36898922	THERMISTOR PROBE	1
36842300	START/RUN SOLENOID VALVE	1
36842318	COMPRESSOR SOLENOID VALVE	1
36847838	AIR FILTER RESTRICTION INDICATOR SWITCH	2
36870608	ENGINE OIL PRESSURE SENDER	1
36841138	COMPRESSOR AND ENGINE TEMPERATURE SENDER	2
36757581	COMPRESSOR OIL PRESSURE SWITCH	1
36850691	COMPRESSOR MOTOR	1
35577873	RELAY, MAGNETIC 24V K1	1
36841526	CONTROL HEATER	2
54658323	NEGATIVE BATTERY CABLE	1
54658331	POSITIVE BATTERY CABLE	1
54511282	POSITIVE JUMPER BATTERY CABLE	1
35128982	BATTERY JUMPER	1
22132153	FRAME GROUND STRAP	1
22132153	ENGINE GROUND STRAP	1
22094759	FUEL LEVEL SENDER	1
54688411	WEDGE CONTROLLER	1
22110779	W1 CHASSIS HARNESS	1
22094650	HARNESS DIAGRAM	N/A
22101901	MACHINE ID PLUG, 154.0K OHMS	1
22101968	INLET HEATER, 120 AMPS	1
36853521	INLET HEATER RELAY	1
89303127	EMERGENCY STOP OPERATOR	1
89303135	NC E-STOP CONTACT BLOCK	2

FAULT	CAUSE	REMEDY
No reaction from instrument panel when key turned to (I) position.	<i>Emergency stop actuated.</i>	Reset emergency stop button.
	<i>Batteries not connected.</i>	Connect batteries.
	<i>Fuse at starter motor 'blown'.</i>	Replace fuse.
Engine fails to start.	<i>Low battery charge.</i>	Check the fan belt tension, battery and cable connections.
	<i>Bad earth connection.</i>	Check the earth cables, clean as required.
	<i>Loose connection.</i>	Locate and make the connection good.
	<i>Fuel starvation.</i>	Check the fuel level and fuel system components. Replace the fuel filter if necessary.
	<i>Relay failed.</i>	Replace the relay.
	<i>Faulty stop solenoid</i>	Check the stop solenoid
Engine stops while in service or is reluctant to start.	<i>Low fuel level.</i>	Fill fuel tank and bleed air from fuel system if necessary. (Refer to <i>MAINTENANCE SECTION</i>).
	<i>Safety shut-down system in operation.</i>	Check the safety shut-down switches.
Engine starts but stalls when the switch returns to position I.	<i>Electrical fault</i>	Test the electrical circuits.
	<i>Low engine oil pressure.</i>	Check the oil level and the oil filter(s).
	<i>Low water level</i>	Check if the low water lamp is extinguished.
	<i>Faulty relay</i>	Check the relays.
	<i>Faulty key-switch</i>	Check the key-switch.
Engine starts but will not run or engine shuts down prematurely.	<i>Electrical fault.</i>	Test the electrical circuits.
	<i>Low engine oil pressure.</i>	Check the oil level and oil filter(s).
	<i>Safety shut-down system in operation.</i>	Check the safety shut-down switches.
	<i>Fuel starvation.</i>	Check the fuel level and fuel system components. Replace the fuel filter if necessary.
	<i>Switch failure.</i>	Test the switches.
	<i>High compressor oil temperature.</i>	Check the compressor oil level and oil cooler. Check the fan drive.
	<i>Water present in fuel system.</i>	Check the water separator and clean if required.
	<i>Faulty relay.</i>	Check the relay in the holder and replace if necessary.

Engine Overheats.	<i>Low water level</i>	Check the level and replenish if necessary.
	<i>Blocked radiator.</i>	Stop the machine and clean the cooling fins with compressed air or steam. Use reduced pressure for cleaning the fins.
	<i>Reduced cooling air from fan.</i>	Check the fan and the drive belts. Check for any obstruction inside the cowl.
Engine speed too low.	<i>Faulty thermostat</i>	Check the thermostat and replace if necessary.
	<i>Blocked fuel filter.</i>	Check and replace if necessary.
	<i>Blocked air filter.</i>	Check and replace the element if necessary.
	<i>Faulty regulator valve.</i>	Check the regulation system.
	<i>Premature unloading.</i>	Check the regulation and the operation of the air cylinder.
	Excessive vibration.	<i>Engine speed too low.</i>
Leaking oil seal.	<i>Improperly fitted oil seal.</i>	Replace the oil seal.
Refer also to the <i>Engine Manufacturer's Manual</i>.		
Air discharge capacity too low.	<i>Engine speed too low.</i>	Check the air cylinder and air filter(s).
	<i>Blocked air cleaner.</i>	Check the restriction indicators and replace the element(s) if necessary.
	<i>High pressure air escaping.</i>	Check for leaks.
	<i>Incorrectly set regulation system.</i>	Reset the regulation system. Refer to <i>SPEED AND PRESSURE REGULATION ADJUSTMENT</i> in the <i>MAINTENANCE</i> section of this manual.
Compressor overheats.	<i>Low oil level.</i>	Top up the oil level and check for leaks.
	<i>Dirty or blocked oil cooler.</i>	Clean the oil cooler fins.
	<i>Incorrect grade of oil.</i>	Use Ingersoll-Rand recommended oil.
	<i>Defective by-pass valve.</i>	Check the operation of the element and replace if necessary.
	<i>Recirculation of cooling air.</i>	Move the machine to avoid recirculation.
	<i>Reduced cooling air from fan.</i>	Check the fan and the drive belts. Check for any obstruction inside the fan cowl.

Excessive oil present in the discharge air.	<i>Blocked scavenge line.</i> <i>Perforated separator element.</i> <i>Pressure in the system is too low.</i>	Check the scavenge line, drop tube and orifice. Clean and replace. Replace the separator element. Check the minimum pressure valve.
Safety valve operates.	<i>Operating pressure too high.</i> <i>Incorrect setting of the regulator.</i> <i>Faulty regulator.</i> <i>Inlet valve set incorrectly.</i> <i>Loose pipe/hose connections.</i> <i>Faulty safety valve.</i>	Check the setting and operation of the regulator valve piping. Adjust the regulator. Replace the regulator. Refer to <i>SPEED AND PRESSURE REGULATION ADJUSTMENT</i> in the <i>MAINTENANCE</i> section of this manual. Check all pipe/hose connections. Check the relieving pressure. Replace the safety valve if faulty. DO NOT ATTEMPT A REPAIR.
Oil is forced back into the air filter.	<i>Incorrect stopping procedure used</i> <i>Faulty inlet valve.</i>	Always employ the correct stopping procedure. Close the discharge valve and allow the machine to run on idle before stopping. Check for free operation of the inlet valve(s).
Machine goes to full pressure when started.	<i>Inlet valve set incorrectly. (17/235, 21/215)</i> <i>Faulty load valve.</i>	Refer to <i>SPEED AND PRESSURE REGULATION ADJUSTMENT</i> in the <i>MAINTENANCE</i> section of this manual. (17/235, 21/215) Replace the valve.
Machine fails to load when the load button is pressed.	<i>Faulty load valve.</i>	Replace the valve.

IQ SYSTEM OPERATING INSTRUCTIONS – 1

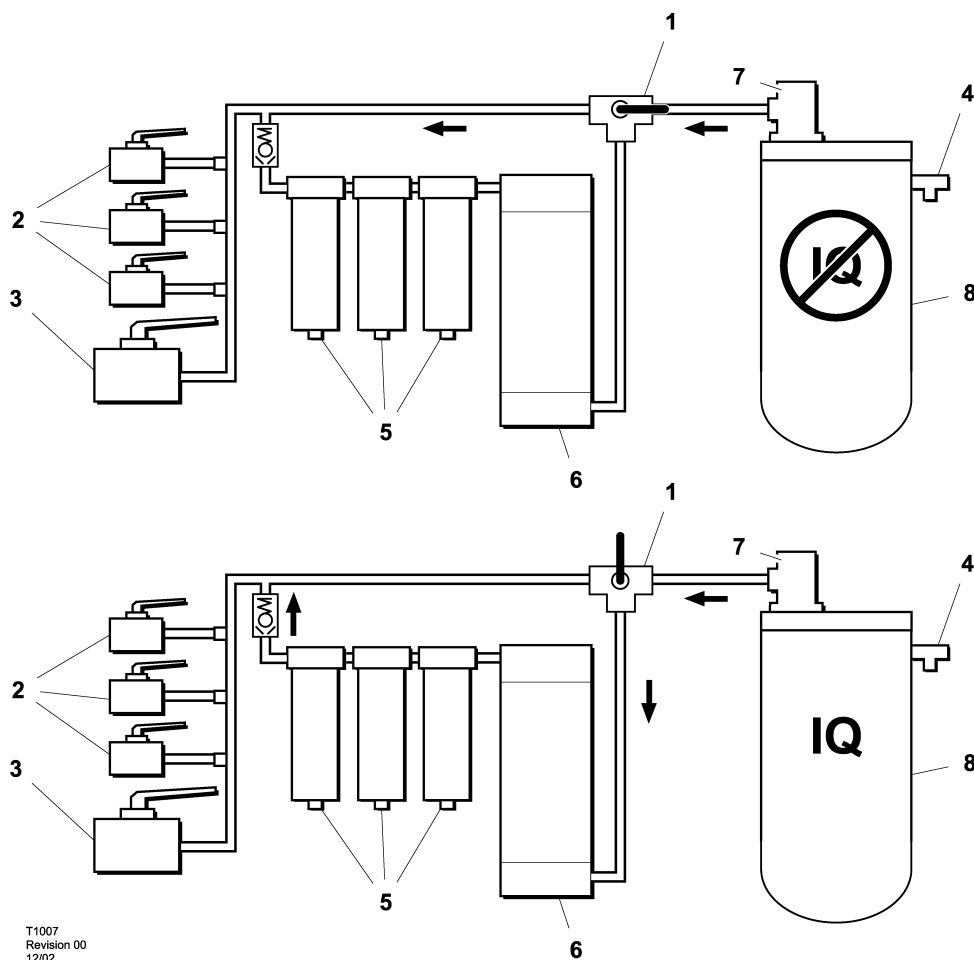

T11007
Revision 00
12/02

KEY

- | | | | |
|---|-------------------|---|------------------------|
| 1 | Three way valve | 5 | Filters |
| 2 | Ball valve 1 1/4" | 6 | Aftercooler |
| 3 | Ball valve 2" | 7 | Minimum pressure valve |
| 4 | Safety valve | 8 | Separator tank |

IQ SYSTEM

The IQ System is a complete, self-contained system which provides cooler, cleaner air than from a standard portable compressor. The system utilizes an integral aftercooler, high-efficiency filtration, and a patented condensate disposal system to provide the cool, clean air. The condensate disposal system injects all liquid condensed from the moisture separator and filters into the engine exhaust system where it is vaporized by heat. This eliminates the need for collecting the condensate, and the added cost of disposing of the condensate, which is often regulated by local, state, and/or federal regulations.

When equipped with the low ambient feature, the IQ System automatically adjusts movable louvers to control airflow through the aftercooler, ensuring that the compressed air temperature always remains above freezing temperatures (typically 45°F) at any ambient temperature down to -20°F. This prevents the need for 120V AC heat tracing systems, or any manual adjustment to prevent freezing of the compressed air system. All drain points for the condensate handling system are heated with 24VDC heaters, which are integral to the compressor heater system. Standard Non-Louvered configuration not to be operated below freezing.

IQ SYSTEM OPERATING INSTRUCTIONS – 2

The compressed air exits the separator tank through the top cover piping, and can then travel along one of two paths, selectable via manual valving.

One path allows Standard Operation, which bypasses the IQ System, and delivers air quality equivalent to a standard oil-flooded portable compressor. If the IQ System is enabled by proper setting of the selector valve, the compressed air first enters the aftercooler.

The aftercooler is cooled by the incoming compressor package air, which is controlled by movable louvers mounted on the aftercooler (if equipped with low ambient option). At most conditions, the louvers are fully open, and maximum aftercooling is available. The compressed air and condensate (water with a small amount of compressor lubricant) exits the aftercooler and enters the moisture separator, where most of the condensate is removed. The compressed air then flows through two stages of filtration, where the aerosol water and oil is removed down to approximately 0.01 ppm, and all particulates are removed down to 0.01 micron.

At the bottom of the moisture separator and both filters are strainers and constant-bleed orifices, which are sized to allow the maximum flow of condensate while minimizing compressed air loss.

The condensate lines are then piped together, and the condensate is injected at a single point into the engine exhaust piping. The compressed air then travels through the minimum pressure valve, and out through the service air valve. The air pressure gauge on the instrument panel indicates the pressure inside the separator tank. A service air pressure gauge is located inside the front door of the compressor on the filter support.

If the IQ System is bypassed (Standard Operation selected), the delivered air pressure will be approximately equal to the separator tank pressure. If the IQ System operation is selected, the delivered air pressure will be slightly less, depending on the restriction of the filters.

Low Ambient Option Operation

When the ambient temperature falls to the point that the aftercooler outlet temperature is approaching 45°F, the Temperature Control Unit (TCU), mounted on the rear of the control panel, will automatically adjust the louvers to control the cooling airflow through the aftercooler.

In the event that the unit is operating under abnormal conditions (i.e., an enclosure door open) which would cause excessive cooling of the aftercooler, a temperature sensor in the aftercooler outlet header will signal the TCU to further close the louvers if the compressed air temperature falls to approximately 36°F or lower.

There are no user selectable or serviceable components in the TCU. Contact Ingersoll-Rand Service if any abnormal operation of the freeze protection control system occurs.

MAINTENANCE

Daily Maintenance:

Verify, during full-load (maximum compressed air delivery) that the IQ System filter restriction indicators do not show excessive restriction. Restriction indicators for the filters are mounted inside the control panel, and will shut down the compressor if restriction exceeds recommended values.

Weekly Maintenance:

- Remove Y-strainer screens at the bottom of the moisture separator and both filters and clean out any residue.
- Verify that the orifices below the Y-strainers are not clogged.
- Verify that the piping from the orifice purge points to the exhaust system is not clogged.

Yearly Maintenance:

The normal maintenance interval on the primary and secondary IQ System filters is one year, or earlier if pressure drop becomes excessive. Restriction indicators for the filters are mounted on the filter support inside the front door, and will shut down the compressor if restriction exceeds recommended values.

Filter Replacement

- With engine stopped, ensure pressure is relieved from air system.
- Remove all wires and hoses connected to drains on bottom of each filter housing. Inspect fittings and hoses for any blockage. Clean if necessary.
- Using a chain wrench or similar tool, loosen the housing. The housing should be removed by hand after loosening, taking care to prevent the housing from falling to the floor panel.
- Lower the housing to floor panel and lean it against the airend. Remove and replace the filter element, being careful not to damage outer wrap.

Verify the part number of new element vs. old element, as the two IQ filters are of different media.

OPTIONS – IQ SYSTEM

SAFETY

CAUTION: The compressor regulation system is adjusted to maintain regulated pressure at the separator tank. DO NOT adjust regulation to provide full regulation pressure at the service valve when the IQ System is enabled. This will result inC operation at excessive horsepower levels, causing overheating, reduced engine life, and reduced airend life.

CAUTION: Excessively restricted filter elements may cause an increase in the amount of aerosol water and oil carryover, which could result in damage to downstream equipment. Normal service intervals should not be exceeded.

CAUTION: Blockage of the condensate will result in flooding of the vessels. If flooding occurs, excessive condensate may enter the air stream and could result in damage to downstream equipment.

NOTICE:
Do not operate at temperatures less than 2°C (35°F) unless equipped with low ambient IQ option.

GENERAL

This publication, which contains an illustrated parts breakdown, has been prepared as an aid in locating those parts which may be required in the maintenance of the unit. All of the compressor parts, listed in the parts breakdown, are manufactured with the same precision as the original equipment. For the greatest protection always insist on genuine Ingersoll-Rand Company parts for your compressor.

NOTICE

Ingersoll-Rand Company can bear no responsibility for injury or damages resulting directly from the use of non-approved repair parts.

Ingersoll-Rand Company service facilities and parts are available worldwide. There are Ingersoll-Rand Company Construction Equipment Group Sales Offices and authorized distributors located in the principal cities of the United States. In Canada our customers are serviced by the Canadian Ingersoll-Rand Company, Limited. There are also Ingersoll-Rand International autonomous companies and authorized distributors located in the principal cities throughout the free world.

Special order parts may not be included in this manual. Contact the Mocksville Parts Department with the unit serial number for assistance with these special parts.

DESCRIPTION

The illustrated parts breakdown illustrates and lists the various assemblies, subassemblies and detailed parts which make up this particular machine. This covers the standard models and the more popular options that are available.

A series of illustrations show each part distinctly and in location relative to the other parts in the assembly. The part number, the description of the part and the quantity of parts required are shown on each illustration or on adjacent page. The quantities specified are the number of parts used per one assembly and are not necessarily the total number of parts used in the machine. Where no quantity is specified the quantity is assumed to be one.

Each description of a part is based upon the "noun first" method, i.e., the identifying noun or item name is always the first part of the description. The noun name is generally followed by a single descriptive modifier. The descriptive modifier may be followed by words or abbreviations such as upper, lower, inner, outer, front, rear, RH, LH, etc. when they are essential.

In referring to the rear, the front or to either side of the unit, always consider the **drawbar end** of the unit as the **front**. Standing at the rear of the unit facing the drawbar (front) will determine the right and left sides.

FASTENERS

Both SAE/inch, ISO/metric hardware have been used in the design and assembly of these units. In the disassembly and reassembly of parts, extreme care must be taken to avoid damaging threads by the use of wrong fasteners. In order to clarify the proper usage and for exact replacement parts, all standard fasteners have been identified by part number, size and description. This will enable a customer to obtain fasteners locally rather than ordering from the factory. These parts are identified in tables that will be found at the rear of the parts illustrations. Any fastener that has not been identified by both part number and size is a specially engineered part that must be ordered by part number to obtain the exact replacement part.

MARKINGS AND DECALS**NOTICE**

Do not paint over safety warnings or instructional decals. If safety warning decals become illegible, immediately order replacements from the factory.

Part numbers for original individual decals and their mounting locations are shown within Parts List Section. These are available as long as a particular model is in production.

Afterwards, service sets of exterior decals and current production safety warning decals are available. Contact the Product Support Group at Mocksville for your particular needs and availability.

HOW TO USE PARTS LIST

- a. Turn to Parts List.
- b. Locate the area or system of the compressor in which the desired part is used and find illustration page number.
- c. Locate the desired part on the illustration by visual identification and make note of part number and description.

HOW TO ORDER

The satisfactory ordering of parts by a purchaser is greatly dependent upon the proper use of all available information. By supplying your nearest sales office, autonomous company or authorized distributor, with complete information, you will enable them to fill your order correctly and to avoid any unnecessary delays.

In order that all avoidable errors may be eliminated, the following instructions are offered as a guide to the purchaser when ordering replacement parts:

- a. Always specify the model number of the unit as shown on the general data decal attached to the unit.
- b. Always specify the serial number of the unit. **THIS IS IMPORTANT.** The serial number of the unit will be found stamped on a plate attached to the unit. (The serial number on the unit is also permanently stamped in the metal of the frame side rail.)
- c. Always specify the number of the parts list publication.
- d. Always specify the quantity of parts required.
- e. Always specify the part number, as well as the description of the part, or parts, exactly as it is given on the parts list illustration.

In the event parts are being returned to your nearest sales office, autonomous company or authorized distributor, for inspection or repair, it is important to include the serial number of the unit from which the parts were removed.

TERMS AND CONDITIONS ON PARTS ORDERS

Acceptance: Acceptance of an offer is expressly limited to the exact terms contained herein. If purchaser's order form is used for acceptance of an offer, it is expressly understood and agreed that the terms and conditions of such order form shall not apply unless expressly agreed to by Ingersoll-Rand Company ("Company") in writing. No additional or contrary terms will be binding upon the Company unless expressly agreed to in writing.

Taxes: Any tax or other governmental charge now or hereafter levied upon the production, sale, use or shipment of material and equipment ordered or sold is not included in the Company's price and will be charged to and paid for by the Purchaser.

Shipping dates shall be extended for delays due to acts of God, acts of Purchaser, acts of Government, fires, floods, strikes, riot, war, embargo, transportation shortages, delay or default on the part of the Company's vendors, or any other cause beyond the Company's reasonable control.

Should Purchaser request special shipping instruction, such as exclusive use of shipping facilities, including air freight when common carrier has been quoted and before change order to purchase order can be received by the Company, the additional charges will be honored by the Purchaser.

Warranty: The Company warrants that parts manufactured by it will be as specified and will be free from defects in materials and workmanship. The Company's liability under this warranty shall be limited to the repair or replacement of any part which was defective at the time of shipment provided Purchaser notifies the Company of any such defect promptly upon discovery, but in no event later than three (3) months from the date of shipment of such part by the Company. The only exception to the previous statement is the extended warranty as it applies to the special aircend exchange program.

Repairs and replacements shall be made by the Company F.O.B. point of shipment. The Company shall not be responsible for costs of transportation, removal or installation.

Warranties applicable to material and equipment supplied by the Company but wholly manufactured by others shall be limited to the warranties extended to the Company by the manufacturer which are able to be conveyed to the Purchaser.

Delivery: Shipping dates are approximate. The Company will use best efforts to ship by the dates specified; however, the Company shall not be liable for any delay or failure in the estimated delivery or shipment of material and equipment or for any damages suffered by reason thereof.

The company makes no other warranty or representation of any kind whatsoever, expressed or implied, except that of title, and all implied warranties, including any warranty of merchantability and fitness for a particular purpose, are hereby disclaimed.

Limitation of Liability:

The remedies of the Purchaser set forth herein are exclusive, and the total liability of the Company with respect to this order whether based on contract, warranty, negligence, indemnity, strict liability or otherwise, shall not exceed the purchase price of the part upon which such liability is based.

The Company shall in no event be liable to the Purchaser, any successors in interest or any beneficiary of this order for any consequential, incidental, indirect, special or punitive damages arising out of this order or any breach thereof, or any defect in, or failure of, or malfunction of the parts hereunder, whether based upon loss of use, lost profits or revenue, interest, lost goodwill, work stoppage, impairment of other goods, loss by reason of shutdown or non-operation, increased expenses of operation or claims of customers of Purchaser for service interruption whether or not such loss or damage is based on contract, warranty, negligence, indemnity, strict liability or otherwise.

AIREND EXCHANGE PROGRAM

Ingersoll-Rand offers an airend exchange program to benefit portable compressor users.

On the airend exchange program the exchange price is determined by the age and condition of the airend.

Your nearest sales office, autonomous company or authorized distributor must first contact the Parts Service Department at the factory at which your portable air compressor was manufactured for an airend exchange number. The airend must be tagged with this preassigned number and returned to the factory prepaid. The airend must be intact, with no excluded parts, otherwise the exchange agreement may be cancelled. The warranty on an exchange or factory rebuilt airend is 365 days.

Airends being returned to the factory in connection with a WARRANTY CLAIM must be processed through the Customer Service Department. If returned without a Warranty MRR (Material Return Request) Number, no warranty claim will be considered.

52 PARTS ORDERING

For parts, service or information regarding your local U.S, Latin America or Asia Pacific distributor, please contact:

Facility:	Telephone:	Fax:
Ingersoll–Rand Company	800–633–5206 (US & Canada)	336–751–1579 (US & Canada)
501 Sanford Avenue	305–222–0835 (Latin America)	336–751–4325 (Latin America)
P.O. Box 868	65–860–6863 (Asia Pacific)	336–751–4325 (Asia Pacific)
Mocksville, N.C. 27028		

Office hours: Monday – Friday 8:00 a.m. to 5:30 p.m. (EST)

For information on how to order parts or information regarding your local distributor (Europe, Middle East, Africa) please contact:

Facility:

Portable Power Aftermarket ESA
Ingersoll–Rand European Sales Ltd
Swan Lane, Hindley Green
Wigan WN2 4 EZ
United Kingdom

Telephone: +44 (0) 1942 257 171

Emergency order telephone # +44 (0) 777 617 0921

Fax: +44 (0) 1942 523 417

Office hours: Monday – Friday 8:00 a.m. to 4:30 p.m. (GMT)

