

D41-2  
JUN

**From:** Nektar Notifications <notifications@nektar.io>  
**Sent:** Friday, May 8, 2026 10:12 AM  
**To:**  
**Subject:** EXTERNAL: 500 Hour Service on 82020033163 (ADT-5401 • JOHN DEERE • 400D • Nisku Main Yard)

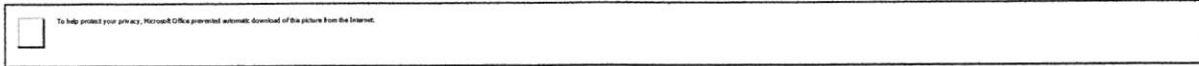

This email was generated by the asset management platform. Below you will find details about a task the user has requested to be shared with you.

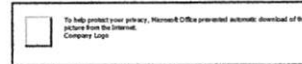

You have received this email because the automation **Record of 500HR for updating titan** was triggered by a **500 Hour Service** task being updated.

Pressing **'Reply'** will reply to Darryl Matchem ( )



**Comments From User:** No comments included.

## Task Summary

### Service

Recorded By: Matthew Scheideman (matthew.chemco) - 5/8/2026 8:41:28 AM (UTC-6)

Engine hours	9898	Change Engine Oil and Filter	1. Pass
Engine Oil Sample Taken/Submitted	1. Pass	Change Fuel Filters	1. Pass
Change Water Separator	1. Pass	Change Engine Air Filters	1. Pass
Change Cabin Air Filters	1. Pass	Grease Complete unit	2. Fail
Check All Fluid Levels	2. Fail	Update Service Decal	1. Pass

<b>Updated Service Decal Photo</b>		<b>Next 500 Service Due @</b>	10398
<b>Fluids Used (Quantity/ Type)</b>	30L 5w-40	<b>Maintenance Remarks (defects/complaints)</b>	-
<b>Operational Status</b>	Operational	<b>Defect Picture 1</b>	-
<b>Defect Picture 2</b>	-	<b>Defect Picture 3</b>	-
<b>Defect Picture 4</b>	-	<b>Front Left Picture</b>	-
<b>Front Right Picture</b>	-	<b>Rear Left Picture</b>	-
<b>Rear Right Picture</b>	-	<b>Technicians sign off</b>	
<b>Service Manager Approved</b>			



Nektar Inc.  
14420 154 Ave, Edmonton, Alberta T6V 0K8

You are receiving this email on behalf of Chemco, who is a client of .

**WRENCHHEAD MECHANICAL**  
 3135 4 ST  
 NISKU, ALBERTA. T9E-8L1  
 Phone: 780-436-9570 Fax: 780- -

*Rd*

**INVOICE**

**51420**

**INVOICE**

Printed Date: 12/12/2025 Work Completed: 12/12/2025

**CHEMCO-OFF ROAD**  
 3135-4 ST  
 NISKU, ALBERTA T9E-8L1  
 Office 780-436-9570

2006 JOHN DEERE - 400D 6X6 UNIT#ADT-5401 -  
 Lic # : Odometer In : 0  
 Unit # : ADT-5401  
 VIN # : DW400DT605401

Part Description / Number	Qty	Sale	Ext	Labor Description	Ext
31 SERIES TOP-POST BATTERY-STK 31P-MHD	2.00	158.43	316.86	**PARTS ONLY NEKTAR W/O 178 **	n/c

Org. Estimate 332.70 Revisions 0.00 Current Estimate 332.70

Labor:	0.00
Parts:	316.86
SubTotal:	316.86
Tax:	15.84
Total:	332.70
Bal Due:	\$332.70

*STK-317*

[ Payments - ]

Vehicle Received: 12/12/2025

Customer Number : 3904

GST#865376503RT0001

Signature \_\_\_\_\_ Date \_\_\_\_\_

**WRENCHHEAD MECHANICAL**  
 3135 4 ST  
 NISKU, ALBERTA. T9E-8L1  
 Phone: 780-436-9570 Fax: 780- -

*RM*

**INVOICE**  
**47388**

**INVOICE**

Printed Date: 01/21/2025 Work Completed: 01/21/2025

**CHEMCO-OFF ROAD**  
 3135-4 ST  
 NISKU, ALBERTA T9E-8L1  
 Office 780-436-9570

2006 JOHN DEERE - 400D 6X6 UNIT#ADT-5401 -  
 Lic # : Odometer In : 0  
 Unit # : ADT-5401  
 VIN # : DW400DT605401  
 Engine Hrs In : 9902.0 Engine Hours Out : 9902.0

Part Description / Number	Qty	Sale	Ext	Labor Description	Ext		
4" TORCTITE LAP CLAMP-ORDER 90356B	2.00	12.54	25.08	(1) REPAIRS AS REQUIRED BURNCO 16 * SEE TECH SHEET	455.00		
4" EXHAUST FLEX PIPE-ORDER FMH-400	2.00	26.59	53.18				
5" FLEX PIPE/FT-ORDER FMH-500	3.00	29.17	87.51				
5" FLAT BAND EXHAUST CLAMP-ORDER 89559K	4.00	21.24	84.96				
5" TORCTITE LAP CLAMP-ORDER 90358B	3.00	12.62	37.86				
EXHAUST PIPE-ORDER TT217750	1.00	1,172.33	1,172.33				
M12 LOCK NUT-ORDER A31867	4.00	3.60	14.40				
13MM WASHER-ORDER 24M7429	2.00	2.68	5.36				
M12 X 40MM HEX HEAD SCREW-ORDER 19M7493	7.00	2.63	18.41				
M8 FLANGE NUT-ORDER 14M7298	1.00	3.32	3.32				
8MM WASHER-ORDER 24M7055	5.00	1.16	5.80				
V BAND CLAMP-ORDER TT218505	1.00	791.85	791.85				
EXHAUST PIPE-ORDER T226087	1.00	1,675.96	1,675.96				
EXHAUST MUFFLER SILENCER CLAMP-ORDER TT217751	2.00	649.13	1,298.26				
PTO POWERGARD SHIELD-ORDER AT363620	1.00	895.88	895.88				
Shop Supplies			22.75				

**WRENCHHEAD MECHANICAL**  
3135 4 ST  
NISKU, ALBERTA. T9E-8L1  
Phone: 780-436-9570 Fax: 780- -

**INVOICE**

**47388**

**INVOICE**

Printed Date: 01/21/2025

Work Completed: 01/21/2025

**CHEMCO-OFF ROAD**  
3135-4 ST  
NISKU, ALBERTA T9E-8L1  
Office 780-436-9570

2006 JOHN DEERE - 400D 6X6 UNIT#ADT-5401 -  
Lic # : Odometer In : 0  
Unit # : ADT-5401  
VIN # : DW400DT605401  
Engine Hrs In : 9902.0 Engine Hours Out : 9902.0

Part Description / Number	Qty	Sale	Ext	Labor Description	Ext
---------------------------	-----	------	-----	-------------------	-----

Org. Estimate 297.16 Revisions 0.00 Current Estimate 297.16

Labor:	455.00
Parts:	6,192.91
SubTotal:	6,647.91
Tax:	332.40
Total:	6,980.31
Bal Due:	\$6,980.31

[ Payments - ]

STK-23

Vehicle Received: 12/12/2024

Customer Number : 3904

GST#865376503RT0001

Signature \_\_\_\_\_ Date \_\_\_\_\_

**WRENCHHEAD MECHANICAL**

3135 4 ST  
NISKU, ALBERTA. T9E-8L1  
Phone: 780-436-9570 Fax: 780- -

REPAIR ORDER #

**047388**

**REPAIR ORDER - RO**

Scheduled : 12/09/2024 12:30 PM

Print Date : 12/9/2024

**CHEMCO-OFF ROAD**  
3135-4 ST  
NISKU, ALBERTA T9E-8L1  
Office 780-436-9570  
Cust ID :  
Last Service : 12/3/2024

2006 JOHN DEERE - 400D 6X6 UNIT#ADT-5401 -  
Lic # : - ALBERTA  
Unit # : ADT-5401  
VIN # : DW400DT605401  
MFG Date : 5/19/2021  
Current Odom : 0  
Elapsed : 0

**Labor Requested / Part SubTotal**

**Extended**

(1) REPAIRS AS REQUIRED BURNCO 16

195.00

Shop Supplies

Parts Subtotal 0.00

9.75

Parts: 0.00  
Labor: 195.00

Supplies: 9.75

Tax: 10.24

Total: 214.99  
Balance: 214.99

TEARDOWN ESTIMATE: I understand that my vehicle will be reassembled within \_\_\_ days of the date shown above if I choose not to authorize the service recommended. All Parts removed will be discarded unless instructed otherwise: Save all Parts \_\_\_\_. NOT RESPONSIBLE FOR LOSS OR DAMAGE TO MY VEHICLE OR ARTICLES LEFT IN VEHICLES IN CASE OF FIRE, THEFT OR ANY OTHER CAUSE. ALL VEHICLES LEFT MUST HAVE OWN INSURANCE. ANY VEHICLES LEFT OVER 30 DAYS WITHOUT CONSENT WILL BE PROPERTY OF WRENCHHEAD MECHANICAL.

Authorized By \_\_\_\_\_ Date \_\_\_\_\_ Time \_\_\_\_\_





# Shopping Cart(7)



Part	<i>A0T5401</i>	Quantity
Exhaust Pipe Part Number: TT217750		1
Hexagonal Lock Nut, M12 Part Number: A31867		4
Round Hole Washer Part Number: 24M7429		2
Hexagonal Head Screw, M12 X 40 Part Number: 19M7493		7
Hexagonal Flange Nut, M8 Part Number: 14M7298		1
Round Hole Washer Part Number: 24M7055		5
V-Clamp Part Number: TT218505		1

UNIT # <u>A01540</u>	ODOMETER	ENGINE HOURS	DATE
WO#	EQUIPMENT / DESCRIPTION		

ITEM	QTY	PART#	DESCRIPTION	IN STOCK	ORDER
<u>4</u>	<del>2</del>	<u>AN273958</u>	<u>CLAMP 5" u Bolt</u>		
		<u>T226087</u>	<u>TUBE</u>	<u>1506.07.</u>	
	<u>3</u>	<u>TT208717</u>	<u>CLAMP 5" LAP</u>		
	<u>2</u>		<u>5" FLEXPipe</u>		
			<i>[Signature]</i>		
			<u>Dec 16-24</u>		
			<u>12:37 PM</u>		
			<u>WENDY</u>		
		<u>276723A1</u>			
		<u>1964651C1</u>			

2005 S205 MALE FEMALE

\_\_\_\_\_  
 Technician (Print Name) Technicians Signature

Fit-0900

Fit sukithord

**Russell Glazier**

---

**From:** Russell Clinton <russellclinton58@gmail.com>  
**Sent:** Thursday, December 12, 2024 4:05 PM  
**To:** Russell Glazier  
**Subject:** EXTERNAL:

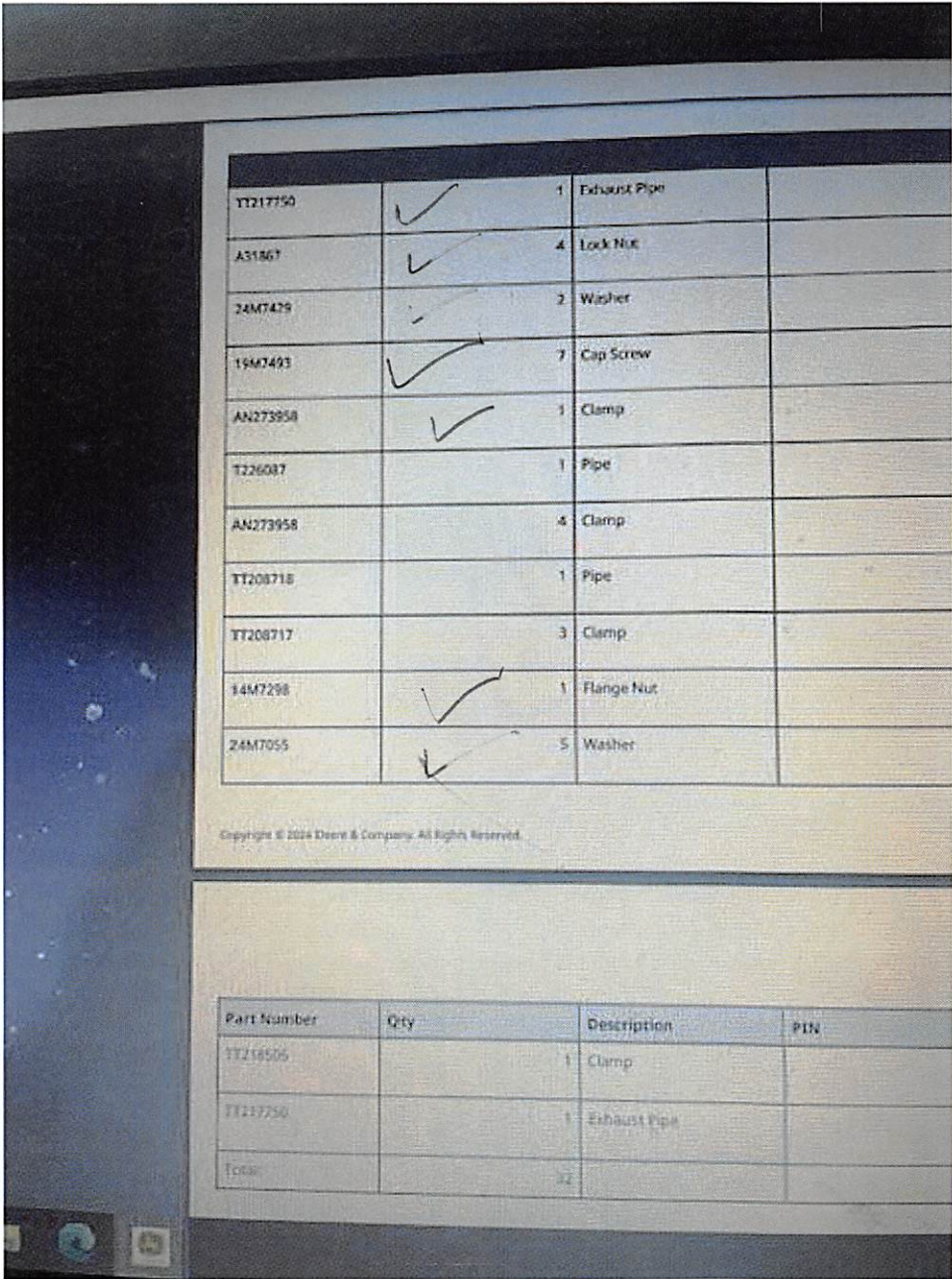

Sent from my iPhone

UNIT #:	A015401	UNIT TYPE/DESCRIPTION:			
Wd#	ODOMETER:	ENGINE HOURS:	DATE:		

ITEM	QTY	PART#	DESCRIPTION	IN STOCK	ORDER
2	2	TT218449	CLAMP	91.71	
	1	TT207826	PIPE	451.60	
			DEC 9-24		
			12:35 pm		
	2-	TT217751	CLAMP		

\_\_\_\_\_  
 Technician (Print Name) \_\_\_\_\_  
 Technicians Signature



**WRENCHHEAD MECHANICAL**  
 3135 4 ST  
 NISKU, ALBERTA. T9E-8L1  
 Phone: 780-436-9570 Fax: 780- -

*RH*

**INVOICE**  
**47335**

**INVOICE**

Printed Date: 12/03/2024 Work Completed: 12/03/2024

**CHEMCO-OFF ROAD**  
 3135-4 ST  
 NISKU, ALBERTA T9E-8L1  
 Office 780-436-9570

2006 JOHN DEERE - 400D 6X6 UNIT#ADT-5401 -  
 Lic # : Odometer In : 0  
 Unit # : ADT-5401  
 VIN # : DW400DT605401  
 Engine Hrs In : 9775.0 Engine Hours Out : 9775.0

Part Description / Number	Qty	Sale	Ext	Labor Description	Ext
BRAKE KLEEN-STK	2.00	3.32	6.64	(1) REPAIRS AS REQUIRED (BURNCO)	390.00
B/C				* DIAGNOSE LEAK. REPAIR LEAK. TEST	
Shop Supplies			19.50		

Org. Estimate 436.95 Revisions 0.00 Current Estimate 436.95

Labor:	390.00
Parts:	26.14
SubTotal:	416.14
Tax:	20.81
Total:	436.95
Bal Due:	\$436.95

[ Payments - ] *STK-27*

Vehicle Received: 12/3/2024

Customer Number : 3904

GST#865376503RT0001  
 Signature \_\_\_\_\_ Date \_\_\_\_\_





# Articulated Truck Maintenance Record

LC-100

ψ P=Pass F=Fail R=Repaired N/A=Not Applicable

UNIT #:	ODOMETER:	ENGINE HOURS:	DATE:	P	F	R	N/A
ADT-540		9765	Nov. 28/24				
1	LOCKOUT IN PLACE	21	Transmission Oil level / Internal Fluid levels	✓			
2	WHEEL CHOCKS IN PLACE	22	Engine Coolant Fluid Level	✓			
3	OIL Samples	23	Engine Oil Fluid Level	✓			
4	Overall Machine Loose Or Missing Nuts & Bolts, Loose Guards, Cleanliness	23	Radiator Debris, Damage, Leaks	✓			
5	Lights Broken Lamps, lenses, operation	24	Overall Engine Compartment Trash Or Dirt Buildup, Leaks	✓			
6	Steering hydraulic system Leaks, worn hoses, damaged lines	25	All Hoses Cracks, Wear Spots, leaks	✓			
7	Undercarriage Machine Leaks, Damage, People Working	26	All Seals Tightness, Wear, Cracks	✓			
8	Tires, Tires, hub, stem caps Inflation, Leaks, Damage, Wear	27	Overall Cab Interior Cleanliness	✓			
9	Brakes, Suspension Leaks, Damage, Wear	28	Roll Over Protection System Damage	✓			
10	Grab Irons, Steps, Handholds Condition And Cleanliness	29	Gauges, lights, switches Damage, operation	✓			
11	Battery Compartment Connections, Fluid level	30	Seat Belt, Buckle & Mounting Damage, Wear, Adjustment	✓			
12	Air Filter Restriction Indicator	31	Seat Adjustment, Brake Travel	✓			
13	Windshield Wipers & Washers Wear, Damage, Fluid Level	32	Horn, backup alarm, lights Proper Function	✓			
14	Fire Extinguisher Charge, Damage	33	Windows and Mirrors Condition, clean, adjust	✓			
15	Fuel tank, hydraulic tank Level, Leaks	34	Drop Box Flights / Internals	✓			
16	Body Damage, wear, distortion	35	Preheat / Block heater	✓			
17	Welds, castings, mounting bolts and pads Cracks, damaged bolts or pads	36	SPILL KIT PROVIDED	✓			
18	All Axles Leaks, Damage, Wear	37	Daily Inspection Booklet	✓			
19	Frame & Hoist Cylinders Cracks, Leaks, Damage, Wear	38	FIRE EXTINGUISHER CONDITION, DATE, TAG, LOCK MOUNT	✓			
20	Suspension Cylinders Leaks, Missing cylinder halves	39	INSPECTION TAG DATE	✓			
41	DRIVE OIL & OIL	40	FIRE EXTINGUISHER	✓			
		41	Air Conditioner Operation	✓			



# Articulated Truck Maintenance Record

LC-100

✓ = Pass    ✗ = Fail    R = Replaced    N/A = Not Applicable

FLUIDS	CHECKED	CHANGED	QUANTITY ADDED & GRADE	SOS SAMPLE
Engine Oil		✓	34L	✓
Transmission Oil	✓			
Hydraulic Oil	✓			
Final Drive L. Front	✓			
Final Drive L. Center	✓			
Final Drive L. Rear	✓			
Final Drive R. Front	✓			
Final Drive R. Center	✓			
Final Drive R. Rear	✓			
Differential Front	✓			
Differential Center	✓			
Differential Rear	✓			
Drop Box / Transfer Case	✓			
Brake Fluid - 5 Containers	✓			
Coolant	✓			

FILTERS	CHECKED	CHANGED	PART #
Engine Oil		✓	FTDC 22513
Fuel		✓	FTDC 22512
Transmission	✓		
Hydraulic	✓		
Inner Air	✗	✓	TI 221378
Outer Air	✗	✓	AH 170798
Cab Filter (Inner/Outer)	✗	✓	TI 226019

## COMMENTS

[Empty box for comments]

Technician (Print Name) Bradley Skonek Technician (Signature)

**WRENCHHEAD MECHANICAL**

3135 4 ST  
NISKU, ALBERTA. T9E-8L1  
Phone: 780-436-9570 Fax: 780-

**INVOICE**

**47166**

**INVOICE**

Printed Date: 11/22/2024

Work Completed: 11/22/2024

**CHEMCO-OFF ROAD**  
3135-4 ST  
NISKU, ALBERTA T9E-8L1  
Office 780-436-9570

2006 JOHN DEERE - 400D 6X6 UNIT#ADT-5401 -  
Lic # : Odometer In : 0  
Unit # : ADT-5401  
VIN # : DW400DT605401

Part Description / Number	Qty	Sale	Ext	Labor Description	Ext
OIL FILTER-ORDER TTDC221513	1.00	61.65	61.65	PARTS ONLY, SENT TO BURNCO	n/c
CABIN AIR FILTER-ORDER TT226019	1.00	207.93	207.93		
FUEL FILTER-ORDER TTDC221512	1.00	53.62	53.62		
FUEL FILTER-ORDER RE171321	1.00	33.65	33.65		
AIR DRYER FILTER-ORDER AT411898	1.00	379.49	379.49		
AIR FILTER-ORDER TT221378	1.00	214.09	214.09		
AIR FILTER-ORDER AH170798	1.00	270.73	270.73		

Org. Estimate 1,282.22 Revisions 0.00 Current Estimate 1,282.22

Labor:	0.00
Parts:	1,221.16
<b>SubTotal:</b>	<b>1,221.16</b>
<b>Tax:</b>	<b>61.06</b>
<b>Total:</b>	<b>1,282.22</b>
<b>Bal Due:</b>	<b>\$1,282.22</b>

[ Payments - ]

Vehicle Received: 11/22/2024

Customer Number : 3904

GST#865376503RT0001

Signature \_\_\_\_\_ Date \_\_\_\_\_

**WRENCHHEAD MECHANICAL**  
 3135 4 ST  
 NISKU, ALBERTA. T9E-8L1  
 Phone: 780-436-9570 Fax: 780- -

*Rd*

**INVOICE**  
**45386**

**INVOICE**

Printed Date: 07/29/2024 Work Completed: 07/29/2024

**CHEMCO-OFF ROAD**  
 3135-4 ST  
 NISKU, ALBERTA T9E-8L1  
 Office 780-436-9570

2006 JOHN DEERE - 400D 6X6 UNIT#ADT-5401 -  
 Lic # : Odometer In : 0  
 Unit # : ADT-5401  
 VIN # : DW400DT605401  
 Engine Hrs In : 9369.0 Engine Hours Out : 9369.0

Part Description / Number	Qty	Sale	Ext	Labor Description	Ext
FUEL FILTER-ORDER RE171321	1.00	31.74	31.74	(1) REPAIRS AS REQUIRED (BURNCO 16) * SEE TECH SHEET	780.00
FUEL FILTER-ORDER TTDC221512	1.00	53.62	53.62		
SYN ATF TRANS OIL 20L PAIL-ORDER ATF-HD-20	2.00	165.97	331.94		
M8 X 16MM FLANGED HEAD SCREW-ORDER 19M-7865	6.00	3.96	23.76		
M10 X 40 FLANGED HEAD SCREW-ORDER 19M7804	3.00	6.21	18.63		
VISCOUS DRIVE-ORDER DC221094 Shop Supplies	1.00	2,334.97	2,334.97		
			39.00		

Org. Estimate 232.95 Revisions 0.00 Current Estimate 232.95

Labor:	780.00
Parts:	2,833.66
SubTotal:	3,613.66
Tax:	180.68
Total:	3,794.34
Bal Due:	\$3,794.34

[ Payments - ]

*stk-39*

Vehicle Received: 6/12/2024

Customer Number : 3904

GST#865376503RT0001

Signature \_\_\_\_\_ Date \_\_\_\_\_

**WRENCHHEAD MECHANICAL**

3135 4 ST  
NISKU, ALBERTA. T9E-8L1  
Phone: 780-436-9570 Fax: 780- -

REPAIR ORDER #

**045386**

**REPAIR ORDER - RO**

Scheduled : 06/10/2024 10:51 AM

Print Date : 6/12/2024

**CHEMCO-OFF ROAD**  
3135-4 ST  
NISKU, ALBERTA T9E-8L1  
Office 780-436-9570  
Cust ID :  
Last Service : 6/10/2024

2006 JOHN DEERE - 400D 6X6 UNIT#ADT-5401 -  
Lic # : - ALBERTA  
Unit # : ADT-5401  
VIN # : DW400DT605401  
MFG Date : 5/19/2021  
Current Odom : 0  
Elapsed : 0

**Labor Requested / Part SubTotal**

**Extended**

(1) REPAIRS AS REQUIRED (BURNCO 16)

130.00

Shop Supplies

Parts Subtotal 85.36

6.50

Parts: 85.36  
Labor: 130.00

Supplies: 6.50

Tax: 11.09

Total: 232.95  
Balance: 232.95

TEARDOWN ESTIMATE: I understand that my vehicle will be reassembled within \_\_\_days of the date shown above if I choose not to authorize the service recommended. All Parts removed will be discarded unless instructed otherwise: Save all Parts\_\_\_. NOT RESPONSIBLE FOR LOSS OR DAMAGE TO MY VEHICLE OR ARTICLES LEFT IN VEHICLES IN CASE OF FIRE, THEFT OR ANY OTHER CAUSE. ALL VEHICLES LEFT MUST HAVE OWN INSURANCE. ANY VEHICLES LEFT OVER 30 DAYS WITHOUT CONSENT WILL BE PROPERTY OF WRENCHHEAD MECHANICAL.

Authorized By \_\_\_\_\_ Date \_\_\_\_\_ Time \_\_\_\_\_







UNIT #:	ADT-5401	UNIT TYPE/DESCRIPTION:	D. 400D ARTICULATED DUMP TRUCK		
WO#	45386	ODOMETER:	ENGINE HOURS:	DATE:	JUNE 20, 24

ITEM	QTY	PART#	DESCRIPTION	IN STOCK	ORDER
✓	1	AT261206	VISCOUS DRIVE		
	6	19M.7865	SCREW		
	3	19M 7804	SCREW		
	✓	DC 221094		2300.00	
		SOUTH AFRICA			
	✓	TTDC 222190	VISCOUS DRIVE		
<div style="border: 1px solid blue; border-radius: 50%; padding: 10px; display: inline-block;"> <p>JUNE 26-24</p> </div>					
<p>WJAX - ZACH (NOPE) (CUSTOMER SUPPORT)</p>					
<p>WESTLOCK TRACTOR - CHUCK (NOPE)</p>					
<div style="background-color: yellow; padding: 10px; border: 1px solid black;"> <p>GARAGE ALAIN ST. PIERRE IN QUEBEC 1-418-251-1052 1 IN STOCK \$ 950.00 WILL PERFORM INSPECTION PRIOR TO SHIPMENT. 30 DAY PARTS WARRANTY PURCHASER \$ 60.00 CAN SHIP MID NEXT WEEK AIR 3 DAYS OR GROUND 5 DAYS</p> </div>					

Technician (Print) \_\_\_\_\_ Technicians Signature \_\_\_\_\_



# Articulated Truck Maintenance Record

**LC-100**

*ADT-5401*

V P = Pass F = Fail R = Repaired N/A = Not Applicable

UNIT #:	ODOMETER:	ENGINE HOURS:	DATE:	P	F	R	N/A
		<i>9369</i>	<i>24/06/25</i>				
				P	F	R	N/A
1	LOCKOUT IN PLACE	21	Transmission Oil level / internals Fluid levels	✓			
2	WHEEL CHOCKS IN PLACE	22	Engine Coolant Fluid Level	✓			
3	Oil Samples	22	Engine Oil Fluid Level	✓			
4	Overall Machine Loose Or Missing Nuts & Bolts, Loose Guards, Cleanliness	23	Radiator Debris, Damage, Leaks	✓			
5	Lights Broken lamps, lenses, operation	24	Overall Engine Compartment Trash Or Dirt Buildup, Leaks	✓			
6	Steering hydraulic system Leaks, worn hoses, damaged lines	25	All Hoses Cracks, Wear Spots, Leaks	✓			
7	Underneath Machine Leaks, Damage, People Working	26	All Belts Tightness, Wear, Cracks	✓			
8	Tires, rims, hub, stem caps Inflation, Leaks, Damage, Wear	27	Overall Cab Interior Cleanliness	✓			
9	Brakes, Suspension Leaks, Damage, Wear	28	Roll Over Protection System Damage	✓			
10	Grab Irons, Steps, Handholds Condition And Cleanliness	29	Gauges, lights, switches Damage, operation	✓			
11	Battery Compartment Connections, Fluid level	30	Seat Belt, Buckle & Mounting Damage, Wear, Adjustment	✓			
12	Air Filter Restriction Indicator	31	Seat Adjustment, Brake Travel	✓			
13	Windshield Wipers & Washers Wear, Damage, Fluid Level	32	Horn, backup alarm, lights Proper Function	✓			
14	Fire Extinguisher Charge, Damage	33	Windows and Mirrors Condition, clean, adjust	✓			
15	Fuel tank, hydraulic tank Level, Leaks	34	Drop Box Fluids / Internals	✓			
16	Body Damage, wear, distortion	35	Preheat / Block Heater	✓			
17	Welds, castings; mounting bolts and pads Cracks; damaged bolts or pads	36	SPILL KIT PROVIDED				
18	All Axles Leaks, Damage, Wear	37	Daily Inspection Booklet	✓			
19	Frame & Hoist Cylinders Cracks, Leaks, Damage, Wear	38	FIRE EXT. CONDITION, DATE, TAG, LOCK, MOUNT				
20	Suspension Cylinders Leaks, Measure cylinder height	39	INSPECTION TAG DATE				
41	Grease Gun & Gease	40	FIRE EXTINGUISHER #:				
		43	Air Conditioning Operation				



Articulated Truck Maintenance Record

LC-100

V P = Pass F = Fail R = Repaired N/A = Not Applicable

FLUIDS	CHECKED	CHANGED	QUANTITY ADDED & GRADE	SOS SAMPLE
Engine Oil	✓			
Transmission Oil		✓	35L ATF	✓
Hydraulic Oil				
Final Drive L. Front				
Final Drive L. Center				
Final Drive L. Rear				
Final Drive R. Front				
Final Drive R. Center				
Final Drive R. Rear				
Differential Front				
Differential Center				
Differential Rear				
Drop Box / Transfer Case				
Brake Fluid - 5 Containers				
Coolant				

FILTERS	CHECKED	CHANGED	PART #
Engine Oil			
Fuel			
Transmission		✓	AT 357236-X2
Hydraulic			
Inner Air			
Outer Air			
Cab Filter (Inner/Outer)			

COMMENTS

CHANGED TRANS FILT. + OIL.

Technician (Print Name)

NORM

Technician (Signature)



# Articulated Truck Maintenance Record

LC-100

*ADT 5401* ✓ P=Pass F=Fail R=Repaired N/A = Not Applicable

UNIT #:		ODOMETER:				ENGINE HOURS: <i>9367</i>		DATE: <i>24/06/19</i>			
		P	F	R	N/A			P	F	R	N/A
1	LOCKOUT IN PLACE	✓				21	Transmission Oil level / Internals Fluid levels	✓			
2	WHEEL CHOCKS IN PLACE	✓				22	Engine Coolant Fluid Level	✓			
3	OIL Samples	✓				22	Engine Oil Fluid Level	✓			
4	Overall Machine Loose Or Missing Nuts & Bolts, Loose Guards, Cleanliness	✓				23	Radiator Debris, Damage, Leaks	✓			
5	Lights Broken lamps, lenses, operation	✓				24	Overall Engine Compartment Trash Or Dirt Buildup, Leaks	✓			
6	Steering hydraulic system Leaks, worn hoses, damaged lines	✓				25	All Hoses Cracks, Wear Spots, Leaks	✓			
7	Underneath Machine Leaks, Damage, People Working	✓				26	All Belts Tightness, Wear, Cracks.	✓			
8	Tires, rims, hub, stem caps Inflation, Leaks, Damage, Wear	✓				27	Overall Cab Interior Cleanliness	✓			
9	Brakes, Suspension Leaks, Damage, Wear	✓				28	Roll Over Protection System Damage	✓			
10	Grab Irons, Steps, Handholds Condition And Cleanliness	✓				29	Gauges, lights, switches Damage, operation	✓			
11	Battery Compartment Connections, Fluid level	✓				30	Seat Belt, Buckle & Mounting Damage, Wear, Adjustment	✓			
12	Air Filter Restriction Indicator	✓				31	Seat Adjustment, Brake Travel	✓			
13	Windshield Wipers & Washers Wear, Damage, Fluid Level	✓				32	Horn, backup alarm, lights Proper Function	✓			
14	Fire Extinguisher Charge, Damage	✓				33	Windows and Mirrors Condition, clean, adjust	✓			
15	Fuel tank, hydraulic tank Level, Leaks	✓				34	Drop Box Fluids / Internals	✓			
16	Body Damage, wear, distortion	✓				35	Preheat / Block Heater	✓			
17	Welds, castings, mounting bolts and pads Cracks, damaged bolts or pads	✓				36	SPILL KIT PROVIDED				
18	All Axles Leaks, Damage, Wear	✓				37	Daily Inspection Booklet				
19	Frame & Holst Cylinders Cracks, Leaks, Damage, Wear	✓				38	FIRE EXT. CONDITION, DATE, TAG, LOCK, MOUNT				
20	Suspension Cylinders Leaks, Measure cylinder height	✓				39	INSPECTION TAG DATE				
						40	FIRE EXTINGUISHER #:				
41	Grease Gun & Gease	✓				43	Air Conditioning Operation				



# Articulated Truck Maintenance Record

LC-100

✓ P = Pass F = Fail R = Repaired N/A = Not Applicable

FLUIDS	CHECKED	CHANGED	QUANTITY ADDED & GRADE	SOS SAMPLE
Engine Oil		✓	40L-5/40	✓
Transmission Oil	✓			
Hydraulic Oil	✓			
Final Drive L. Front				
Final Drive L. Center				
Final Drive L. Rear				
Final Drive R. Front				
Final Drive R. Center				
Final Drive R. Rear				
Differential Front	✓			
Differential Center	✓			
Differential Rear	✓			
Drop Box / Transfer Case	✓			
Brake Fluid - 5 Containers				
Coolant	✓			

FILTERS	CHECKED	CHANGED	PART #
Engine Oil		✓	TTDC 221513
Fuel		✓	RE 171321
Transmission	✓		
Hydraulic	✓		
Inner Air		✓	TT 221378
Outer Air		✓	RA-170798
Cab Filter (Inner/Outer)			WRONG CAB BLEW OUT.

## COMMENTS

WS - TTDC 221512

Technician (Print Name)

*Norme* Technician (Signature)

**WRENCHHEAD MECHANICAL**

3135 4 ST  
NISKU, ALBERTA. T9E-8L1  
Phone: 780-436-9570 Fax: 780- -

AH

**INVOICE**

**45364**

**INVOICE**

Printed Date: 06/10/2024 Work Completed: 06/10/2024

**CHEMCO-OFF ROAD**

3135-4 ST  
NISKU, ALBERTA T9E-8L1  
Office 780-436-9570

2006 JOHN DEERE - 400D 6X6 UNIT#ADT-5401 -

Lic # :  
Unit # : ADT-5401  
VIN # : DW400DT605401

Odometer In : 0

Part Description / Number	Qty	Sale	Ext	Labor Description	Ext
ENGINE OIL FILTER-ORDER TTDC221513	1.00	61.65	61.65	(1) PARTS ONLY, SEND FILTERS TO BURNCO	n/c
CABIN FRESH AIR FILTER-ORDER TT226019	1.00	207.93	207.93		
PRIMARY FUEL FILTER-ORDER RE171321	1.00	31.74	31.74		
FINAL FUEL FILTER KIT-ORDER TTDC221512	1.00	53.62	53.62		
PRIMARY AIR FILTER-ORDER TT221379	1.00	255.43	255.43		
SECONDARY AIR FILTER-ORDER T221378	1.00	214.09	214.09		
TRANSMISSION OIL FILTER-ORDER AT357236	2.00	266.96	533.92		

Org. Estimate 1,426.30 Revisions 0.00 Current Estimate 1,426.30

Labor:	0.00
Parts:	1,358.38
SubTotal:	1,358.38
Tax:	67.92
Total:	1,426.30
Bal Due:	\$1,426.30

[ Payments - ]

STK - 0

Vehicle Received: 6/6/2024

Customer Number : 3904

GST#865376503RT0001

Signature \_\_\_\_\_ Date \_\_\_\_\_

**WRENCHHEAD MECHANICAL**

3135 4 ST  
NISKU, ALBERTA. T9E-8L1  
Phone: 780-436-9570 Fax: 780- -

REPAIR ORDER #

**045364**

**REPAIR ORDER - RO**

Scheduled : 06/06/2024 02:18 PM

Print Date : 6/6/2024

**CHEMCO-OFF ROAD**  
3135-4 ST  
NISKU, ALBERTA T9E-8L1  
Office 780-436-9570  
Cust ID :  
Last Service : 5/28/2024

2006 JOHN DEERE - 400D 6X6 UNIT#ADT-5401 -  
Lic # : - ALBERTA  
Unit # : ADT-5401  
VIN # : DW400DT605401  
MFG Date : 5/19/2021  
Current Odom : 0  
Elapsed : 0

**Labor Requested / Part SubTotal**

**Extended**

(1) PARTS ONLY, SEND FILTERS TO BURNGO

Parts Subtotal 1,358.38

Parts: 1,358.38  
Labor: 0.00

Tax: 67.92

Total: 1,426.30  
Balance: 1,426.30

TEARDOWN ESTIMATE: I understand that my vehicle will be reassembled within \_\_\_ days of the date shown above if I choose not to authorize the service recommended. All Parts removed will be discarded unless instructed otherwise: Save all Parts\_\_\_. NOT RESPONSIBLE FOR LOSS OR DAMAGE TO MY VEHICLE OR ARTICLES LEFT IN VEHICLES IN CASE OF FIRE, THEFT OR ANY OTHER CAUSE. ALL VEHICLES LEFT MUST HAVE OWN INSURANCE. ANY VEHICLES LEFT OVER 30 DAYS WITHOUT CONSENT WILL BE PROPERTY OF WRENCHHEAD MECHANICAL.

Authorized By \_\_\_\_\_ Date \_\_\_\_\_ Time \_\_\_\_\_



**UPTIME MAINTENANCE PLANNER**

REQUIRED PARTS								
Description	Part Number	Initial Service 100 Hours <sup>1</sup>	Every 250 Hours	Every 500 Hours	Every 1000 Hours	Every 2000 Hours	Every 4000 Hours	Every 6000 Hours
Engine Oil Filter Kit	TTDC221513			1	1	1	1	1
Engine Crankcase Breather Filter (S.N. --200802)	TTDC222053			1	1	1	1	1
Cab Fresh Air Filter	TT226019			1	1	1	1	1
Final Fuel Filter Kit	TTDC221512				1	1	1	1
Primary Fuel Filter/Water Separator	RE171321	1			1	1	1	1
Wet Disc Brake Cooling Oil Filter—If Equipped	TT220736				1	1	1	1
Transfer Case Oil Filter—If Equipped	TT222219	1			1	1	1	1
Hydraulic Tank Breather Filter	AT252815				1	1	1	1
Transmission Oil Filters	AT357236	2			2	2	2	2
Hydraulic System Return Filter	TT222389	1				1	1	
Pneumatic System Air Dryer Filter	AT252831					1	1	
Pneumatic Block Silencer/Filter	TT226348						2	
Pneumatic Block Silencer/Filter	TT226349						1	
Hydraulic Suction Screen	AT253803						1	
Air Filter (Primary)	TT221379				As Required			
Air Filter (Secondary)	TT221378				As Required			
Breather (Axle, Transfer Case and Transmission)	AT253791				As Required			
John Deere Plus 50™ II Engine Oil	TY26674 <sup>3</sup>			30.0 L (8.0 gal)	30.0 L (8.0 gal)	30.0 L (8.0 gal)	30.0 L (8.0 gal)	30.0 L (8.0 gal)
Hy-Gard™ Hydraulic Oil	TY6354 <sup>3</sup>						178.0 L (47.0 gal)	178.0 L (47.0 gal)
Allison/Castrol TransSynd™ Transmission Oil	TY26392 <sup>3</sup>					38.5 L (10.0 gal)	38.5 L (10.0 gal)	
API GL-5 Gear Oil with Limited Slip Additive	TY25050 <sup>3</sup>	172.0 L (46.0 gal)				172.0 L (46.0 gal)	172.0 L (46.0 gal)	
COOL-GARD™ II Pre-Mix	TY26575							33.6 L (9.0 gal)
Coolant Extender	TY26603						As Required	
<b>Fluid Analysis Kits<sup>4</sup>:</b>								
Diesel Engine Oil	AT317904		1	1	1	1	1	1
Transmission Oil	AT303189			11	11	11	11	11
Hydraulic Oil	AT303189		1	1	1	1	1	1
Diesel Fuel	AT180344			1	1	1	1	1
Engine Coolant	AT183016			1	1	1	1	1
COOL-GARD™ II 3-Way Test Strips	TY26605			1	1	1	1	1

<sup>1</sup> Perform initial service once after the first 100 hours of operation

<sup>2</sup> For use with ethyleneglycol only. Not for use with Caltex extended life coolant.

<sup>3</sup> See operator's manual for oil type and oil viscosities based on operating temperatures

<sup>4</sup> Based on fluid analysis results, intervals may need to be adjusted for your operating conditions. Consult your local John Deere Dealer.

**WRENCHHEAD MECHANICAL**

3135 4 ST  
NISKU, ALBERTA. T9E-8L1  
Phone: 780-436-9570 Fax: 780- -

*RM*

**INVOICE**

**44857**

**INVOICE**

Printed Date: 05/02/2024 Work Completed: 05/02/2024

**CHEMCO-OFF ROAD**  
3135-4 ST  
NISKU, ALBERTA T9E-8L1  
Office 780-436-9570

2006 JOHN DEERE - 400D 6X6 UNIT#ADT-5401 -  
Lic # : Odometer In : 0  
Unit # : ADT-5401  
VIN # : DW400DT605401  
Engine Hrs In : 9182.0 Engine Hours Out : 9182.0

Part Description / Number	Qty	Sale	Ext	Labor Description	Ext
HYD FILTER-STK HF6510	1.00	10.00	10.00	(1) REPAIRS AS REQUIRED (BURNCO 16) * SEE TECH SHEET	325.00
SEAL-ORDER TT226917	1.00	99.13	99.13		
O RING-ORDER AT252926	1.00	13.24	13.24		
BRAKE KLEEN-STK B/C	1.00	3.27	3.27		
Shop Supplies			16.25		

Org. Estimate 153.83 Revisions 0.00 Current Estimate 153.83

Labor:	325.00
Parts:	141.89
SubTotal:	466.89
Tax:	23.34
Total:	490.23
Bal Due:	\$490.23

*STK-30*

[ Payments - ]

Vehicle Received: 5/1/2024

Customer Number : 3904

GST#865376503RT0001

Signature \_\_\_\_\_ Date \_\_\_\_\_

**WRENCHHEAD MECHANICAL**

3135 4 ST

NISKU, ALBERTA. T9E-8L1

Phone: 780-436-9570 Fax: 780- -

REPAIR ORDER #

**044857**

**REPAIR ORDER - RO**

Scheduled : 04/23/2024 04:30 PM

Print Date : 5/1/2024

**CHEMCO-OFF ROAD**

3135-4 ST

NISKU, ALBERTA T9E-8L1

Office 780-436-9570

Cust ID :

Last Service : 4/8/2024

2006 JOHN DEERE - 400D 6X6 UNIT#ADT-5401 -

Lic # : - ALBERTA

Unit # : ADT-5401

VIN # : DW400DT605401

MFG Date : 5/19/2021

Current Odom : 0

Elapsed : 0

**Labor Requested / Part SubTotal**

**Extended**

(1) REPAIRS AS REQUIRED (BURNCO 16)

130.00

Shop Supplies

Parts Subtotal 10.00

6.50

Parts: 10.00

Supplies: 6.50

Labor: 130.00

Tax: 7.33

Total: 153.83

Balance: 153.83

TEARDOWN ESTIMATE: I understand that my vehicle will be reassembled within \_\_\_ days of the date shown above if I choose not to authorize the service recommended. All Parts removed will be discarded unless instructed otherwise: Save all Parts \_\_\_\_. NOT RESPONSIBLE FOR LOSS OR DAMAGE TO MY VEHICLE OR ARTICLES LEFT IN VEHICLES IN CASE OF FIRE, THEFT OR ANY OTHER CAUSE. ALL VEHICLES LEFT MUST HAVE OWN INSURANCE. ANY VEHICLES LEFT OVER 30 DAYS WITHOUT CONSENT WILL BE PROPERTY OF WRENCHHEAD MECHANICAL.

Authorized By \_\_\_\_\_ Date \_\_\_\_\_ Time \_\_\_\_\_

Unit #: ADT-5101

S/N:

Odometer:

Hours: 9182

Lab#	Repair Description	Date	Location	Tech Name	Hours
	Operator complaint of noise from t-case, found t-case output seal leaking. Cut and change t-case filter fluid / filter clean look up seals.	April 30	Turner	Drew	2
	Replace t-case output seal, walk to unit, move to accessible spot to work on.	may 1	Turner	Drew Died!	2 1
					5.0

Parts

Mechanic ID:

Mechanic Signature: 

Qty.	Part #	Description	STK/ORD	Qty.	Part #	Description	STK/ORD
						Car Brake Clean	

P A R T S   Q U O T E

BRANDT TRACTOR  
 10630-176ST  
 EDMONTON, AB                      T5S 1M2  
 (780) 484-6613

Date: 30 APR 24  
 Time:            14:54  
 Expires: 30 MAY 24

For: CHEMCO ELECTRICAL CONT  
 3135 - 4 ST  
 ap@chemco.com  
 NISKU                                      AB   T9E 8L1  
 (780) 436-9570

Slsprsn: CONNOR MACDONALD  
 Quote No: 60010070164  
 Segment No:                              1

*44857 ADT 5401*

-----  
 Make                      Model                      Pin                                      Segment No:      1  
 -----

Qty	Part Number/Description	Wgt	Ext Wgt	Unit Price	Extended Price
<i>✓</i> 1	TT226917                      SEAL			99.13	99.13
1	T242261                      YOKE	8	8	1969.53	1969.53
<i>✓</i> 1	AT252918                      DUST SHIEL			82.38	82.38
<i>✓</i> 1	AT252926                      O-RING			13.24	13.24
	Total Weight		9		
				Total Labor	0.00
				Total Parts	2164.28
				Total Misc	0.00
				Taxes	0.00
				Grand Total	2164.28

Customer may be subject to GST/HST

Quote/Estimate Expires: 30 MAY 24

# Parts List



JOHN DEERE

## Transfer Case Output Shaft, Bearing and Gears (Front) - ST292862

350D and 400D Articulated Dump Truck (Davenport S.N.  
599286-608489) (Non-Davenport S.N.200311-201811) - PC9106 >  
8 Transfer Drive (Includes Splitters) > 0851 Gears, Shafts,  
Bearings

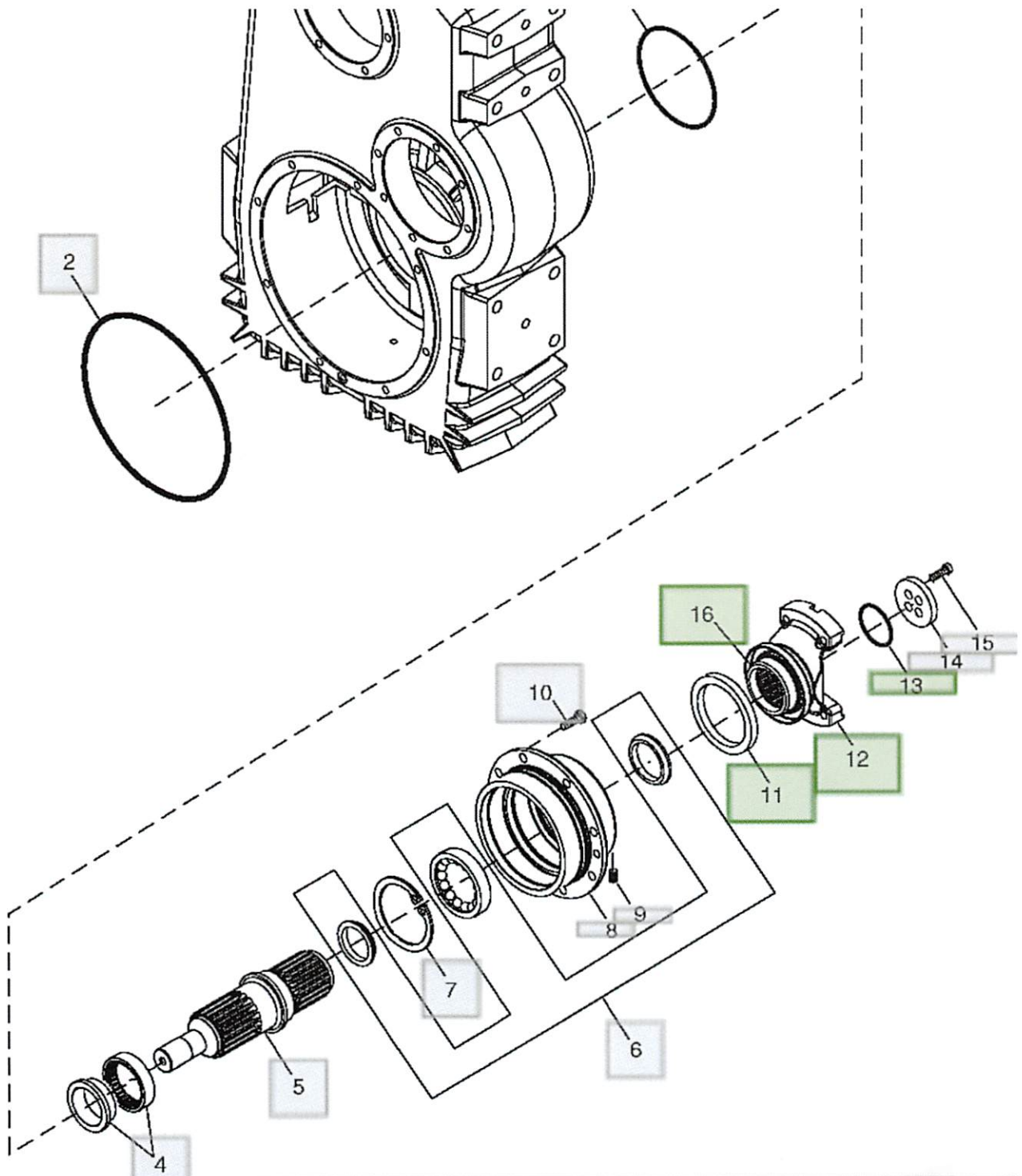

T193455

**WRENCHHEAD MECHANICAL**

3135 4 ST  
NISKU, ALBERTA. T9E-8L1  
Phone: 780-436-9570 Fax: 780- -

*RM*

**INVOICE**

**44550**

**INVOICE**

Printed Date: 04/08/2024 Work Completed: 04/08/2024

**CHEMCO-OFF ROAD**  
3135-4 ST  
NISKU, ALBERTA T9E-8L1  
Office 780-436-9570

2006 JOHN DEERE - 400D 6X6 UNIT#ADT-5401 -  
Lic # : Odometer In : 0  
Unit # : ADT-5401  
VIN # : DW400DT605401  
Engine Hrs In : 9069.0 Engine Hours Out : 9069.0

Part Description / Number	Qty	Sale	Ext	Labor Description	Ext
SEAT-ORDER 58569C24HD	1.00	1,542.67	1,542.67	(1) REPLACE SEAT (BURNCO 16) * REPLACE SEAT	195.00
2.5" LEFT ARMREST-ORDER 87034L	1.00	72.00	72.00		
2.5" RIGHT ARMREST-ORDER 87034R	1.00	72.00	72.00		
3" RETRACTABLE SEATBELT-ORDER 81067	1.00	133.33	133.33		
MOUNTING PLATE-ORDER 88059	1.00	109.33	109.33		
HEADREST-ORDER 870221	1.00	62.67	62.67		
Shop Supplies			9.75		

Org. Estimate 2,449.91 Revisions 0.00 Current Estimate 2,449.91

Labor:	195.00
Parts:	2,001.75
SubTotal:	2,196.75
Tax:	109.84
Total:	2,306.59
Bal Due:	\$2,306.59

[ Payments - ]

*STK-10*

Vehicle Received: 3/28/2024

Customer Number : 3904

GST#865376503RT0001

Signature \_\_\_\_\_ Date \_\_\_\_\_

**WRENCHHEAD MECHANICAL**

3135 4 ST  
NISKU, ALBERTA. T9E-8L1  
Phone: 780-436-9570 Fax: 780- -

REPAIR ORDER #

**044550**

**REPAIR ORDER - RO**

Scheduled : 03/28/2024 09:41 AM

Print Date : 3/28/2024

**CHEMCO-OFF ROAD**  
3135-4 ST  
NISKU, ALBERTA T9E-8L1  
Office 780-436-9570  
Cust ID :  
Last Service : 3/27/2024

2006 JOHN DEERE - 400D 6X6 UNIT#ADT-5401 -  
Lic # : - ALBERTA  
Unit # : ADT-5401  
VIN # : DW400DT605401  
MFG Date : 5/19/2021  
Current Odom : 0  
Elapsed : 0

<i>Labor Requested / Part SubTotal</i>	<b>Extended</b>
(1) REPLACE SEAT (BURNCO 16)	325.00
Shop Supplies	16.25
	<b>Parts Subtotal 0.00</b>

<b>Parts: 0.00</b>	<b>Supplies: 16.25</b>	<b>Tax: 17.06</b>	<b>Total: 358.31</b>
<b>Labor: 325.00</b>			<b>Balance: 358.31</b>

TEARDOWN ESTIMATE: I understand that my vehicle will be reassembled within \_\_\_ days of the date shown above if I choose not to authorize the service recommended. All Parts removed will be discarded unless instructed otherwise: Save all Parts \_\_\_\_. NOT RESPONSIBLE FOR LOSS OR DAMAGE TO MY VEHICLE OR ARTICLES LEFT IN VEHICLES IN CASE OF FIRE, THEFT OR ANY OTHER CAUSE. ALL VEHICLES LEFT MUST HAVE OWN INSURANCE. ANY VEHICLES LEFT OVER 30 DAYS WITHOUT CONSENT WILL BE PROPERTY OF WRENCHHEAD MECHANICAL.

Authorized By \_\_\_\_\_ Date \_\_\_\_\_ Time \_\_\_\_\_



**WRENCHHEAD MECHANICAL**

3135 4 ST  
NISKU, ALBERTA. T9E-8L1  
Phone: 780-436-9570 Fax: 780- -

*Red*

**INVOICE**  
**44318**

**INVOICE**

Printed Date: 03/15/2024 Work Completed: 03/15/2024

**CHEMCO-OFF ROAD**  
3135-4 ST  
NISKU, ALBERTA T9E-8L1  
Office 780-436-9570

2006 JOHN DEERE - 400D 6X6 UNIT#ADT-5401 -  
Lic # : Odometer In : 0  
Unit # : ADT-5401  
VIN # : DW400DT605401  
Engine Hrs In : 9044.0 Engine Hours Out : 9044.0

Part Description / Number	Qty	Sale	Ext	Labor Description	Ext
SEAT COMPRESSOR-ORDER	1.00	264.00	264.00	(1) REPAIRS AS REQUIRED (BURNCO 16)	162.50
570246C24				* SEE TECH SHEET	
Shop Supplies			8.13		

Org. Estimate 456.36 Revisions 0.00 Current Estimate 456.36

Labor:	162.50
Parts:	272.13
SubTotal:	434.63
Tax:	21.73
Total:	456.36
Bal Due:	\$456.36

[ Payments - ] *STK-9*

Vehicle Received: 3/15/2024

Customer Number : 3904

GST#865376503RT0001

Signature \_\_\_\_\_ Date \_\_\_\_\_



**WRENCHHEAD MECHANICAL**  
 3135 4 ST  
 NISKU, ALBERTA. T9E-8L1  
 Phone: 780-436-9570 Fax: 780- -

*RM*  
**INVOICE**  
**42577**

**INVOICE**

Printed Date: 09/19/2023 Work Completed: 09/19/2023

**CHEMCO-OFF ROAD**  
 3135-4 ST  
 NISKU, ALBERTA T9E-8L1  
 Office 780-436-9570

2006 JOHN DEERE - 400D 6X6 UNIT#ADT-5401 -  
 Lic # : Odometer In : 0  
 Unit # : ADT-5401  
 VIN # : DW400DT605401  
 Engine Hrs In : 8900.0 Engine Hours Out : 8900.0

Part Description / Number	Qty	Sale	Ext	Labor Description	Ext
SEAT AIR COMPRESSOR-ORDER 570246C24	1.00	264.00	264.00	(1) REPAIRS AS REQUIRED AT BURSCO ** SEE TECH SHEET	585.00
CLAMP-ORDER AT252689	1.00	91.19	91.19		
SEAL-ORDER TT140622	1.00	317.39	317.39		
10MMX130MM BOLT-ORDER ZCSM10BC-10-130	1.00	1.08	1.08		
DAMPER KIT-ORDER 870302	2.00	84.00	168.00		
WIPER ARM-ORDER T217619	1.00	260.23	260.23		
WIPER BLADE-ORDER TT217618	1.00	77.68	77.68		
DOOR SHOCK-ORDER TT191298	1.00	192.57	192.57		
Shop Supplies			29.25		

Org. Estimate 71.66 Revisions 0.00 Current Estimate 71.66

Labor:	585.00
Parts:	1,401.39
<b>SubTotal:</b>	<b>1,986.39</b>
Tax:	99.32
<b>Total:</b>	<b>2,085.71</b>
Bal Due:	\$2,085.71

[ Payments - ]

*stk-30*

Vehicle Received: 9/8/2023

Customer Number : 3904

GST#865376503RT0001

Signature \_\_\_\_\_ Date \_\_\_\_\_

**WRENCHHEAD MECHANICAL**

3135 4 ST

NISKU, ALBERTA. T9E-8L1

Phone: 780-436-9570 Fax: 780- -

REPAIR ORDER #

**042577**

**REPAIR ORDER - RO**

Scheduled : 09/08/2023 10:07 AM

Print Date : 9/8/2023

**CHEMCO-OFF ROAD**

3135-4 ST

NISKU, ALBERTA T9E-8L1

Office 780-436-9570

Cust ID :

Last Service : 9/7/2023

2006 JOHN DEERE - 400D 6X6 UNIT#ADT-5401 -

Lic # : - ALBERTA

Unit # : ADT-5401

VIN # : DW400DT605401

MFG Date : 5/19/2021

Current Odom : 0

Elapsed : 0

**Labor Requested / Part SubTotal**

**Extended**

(1) REPAIRS AS REQUIRED AT BURNGO

65.00

Shop Supplies

Parts Subtotal 0.00

3.25

Parts: 0.00

Supplies: 3.25

Labor: 65.00

Tax: 3.41

Total: 71.66

Balance: 71.66

TEARDOWN ESTIMATE: I understand that my vehicle will be reassembled within \_\_\_ days of the date shown above if I choose not to authorize the service recommended. All Parts removed will be discarded unless instructed otherwise: Save all Parts \_\_\_\_. NOT RESPONSIBLE FOR LOSS OR DAMAGE TO MY VEHICLE OR ARTICLES LEFT IN VEHICLES IN CASE OF FIRE, THEFT OR ANY OTHER CAUSE. ALL VEHICLES LEFT MUST HAVE OWN INSURANCE. ANY VEHICLES LEFT OVER 30 DAYS WITHOUT CONSENT WILL BE PROPERTY OF WRENCHHEAD MECHANICAL.

Authorized By \_\_\_\_\_ Date \_\_\_\_\_ Time \_\_\_\_\_

Technician Work Sheet      Service Writer : ANDREW, RYAN

Print Date: 9/08/2023

2006 JOHN DEERE - 400D 6X6 UNIT#ADT-540

Hat # :

Repair Order #

VIN # : DW400DT605401

Color :

042577

Engine :

Location :

Lic # :

Lic. State : ALBERTA

**CHEMCO-OFF ROAD**

Office 780-436-9570

Schedule :

Promised Date : 9/08/23 5:00 P.M.

Inspection Date : 5/19/21

Status :

Last Service : 9/07/23

Unit # : ADT-5401

Current Odometer : 0

Trans :

Previous Mileage : 0

Brakes :

Elapsed Mileage : 0

Manufacture Date : 5/19/21

**Labor Description**

**Charged Hours**

(1) REPAIRS AS REQUIRED AT BURSCO

1.00

Technician : <none>

OUT ODOMETER :

Total Hours Charged :

1.00

Hours out: 0.00

**Tech Notes**

---

---

---









**WRENCHHEAD MECHANICAL**  
 3135 4 ST  
 NISKU, ALBERTA. T9E-8L1  
 Phone: 780-436-9570 Fax: 780- -

**INVOICE**

**42455**

Org. Est. # 059229

**INVOICE**

Printed Date: 09/07/2023 Work Completed: 09/07/2023

**CHEMCO-OFF ROAD**  
 3135-4 ST  
 NISKU, ALBERTA T9E-8L1  
 Office 780-436-9570

2006 JOHN DEERE - 400D 6X6 UNIT#ADT-5401 -  
 Lic # : Odometer In : 0  
 Unit # : ADT-5401  
 VIN # : DW400DT605401

Part Description / Number	Qty	Sale	Ext	Labor Description	Ext
THERMOSTAT-ORDER TTDC221577	2.00	273.06	546.12	(1) REPAIRS AS REQUIRED (BURNCO) ** SEE TECH SHEET **	130.00
ORING-ORDER AT255740	2.00	24.11	48.22	** NO TECH SHEET HANDED IN FOR CHANGING THERMOSTAT **	
Shop Supplies			6.50	** NO ENGINE HOURS RECORDED BY TECH **	

Org. Estimate 767.38 Revisions 0.00 Current Estimate 767.38

Labor:	130.00
Parts:	600.84
SubTotal:	730.84
Tax:	36.54
Total:	767.38
Bal Due:	\$767.38

[ Payments - ]

*STK-7*

Vehicle Received: 9/7/2023

Customer Number : 3904

GST#865376503RT0001

Signature \_\_\_\_\_ Date \_\_\_\_\_

WRENCHHEAD MECHANICAL

3135 4 ST  
NISKU, ALBERTA. T9E-8L1  
Phone: 780-436-9570 Fax: 780- -

REPAIR ORDER #

042455

Org. Est. # 059229

REPAIR ORDER - RO

Scheduled : 08/30/2023 03:44 PM

Print Date : 8/30/2023

CHEMCO-OFF ROAD  
3135-4 ST  
NISKU, ALBERTA T9E-8L1  
Office 780-436-9570  
Cust ID : 3904  
Last Service : 8/16/2023

2006 JOHN DEERE - 400D 6X6 UNIT#ADT-5401 -  
Lic # : - ALBERTA  
Unit # : ADT-5401  
VIN # : DW400DT605401  
MFG Date : 5/19/2021  
Current Odom : 0  
Elapsed : 0

Labor Requested / Part SubTotal

Extended

(1) REPAIRS AS REQUIRED (BURNCO)

650.00

Parts Subtotal 0.00

Shop Supplies

32.50

1- TTDC 222276 w/P 3K

1- TTDC 260096 GASKET KIT 800.00

2- TTDC 221577 T STAT 273.06 546.12

4346.12

2- AT 255740

Parts: 0.00  
Labor: 650.00

Supplies: 32.50

Tax: 34.13

Total: 716.63  
Balance: 716.63

TEARDOWN ESTIMATE: I understand that my vehicle will be reassembled within \_\_\_ days of the date shown above if I choose not to authorize the service recommended. All Parts removed will be discarded unless instructed otherwise: Save all Parts \_\_\_\_. NOT RESPONSIBLE FOR LOSS OR DAMAGE TO MY VEHICLE OR ARTICLES LEFT IN VEHICLES IN CASE OF FIRE, THEFT OR ANY OTHER CAUSE. ALL VEHICLES LEFT MUST HAVE OWN INSURANCE. ANY VEHICLES LEFT OVER 30 DAYS WITHOUT CONSENT WILL BE PROPERTY OF WRENCHHEAD MECHANICAL.

Authorized By \_\_\_\_\_ Date \_\_\_\_\_ Time \_\_\_\_\_



**WRENCHHEAD MECHANICAL**

3135 4 ST  
 NISKU, ALBERTA. T9E-8L1  
 Phone: 780-436-9570 Fax: 780- -



**INVOICE**

**40349**

Org. Est. # 057119

**INVOICE**

Printed Date: 02/02/2023 Work Completed: 02/02/2023

**CHEMCO-OFF ROAD**

3135-4 ST  
 NISKU, ALBERTA T9E-8L1  
 Office 780-436-9570

2006 JOHN DEERE - 400D 6X6 UNIT#ADT-5401 -  
 Lic # : Odometer In : 0  
 Unit # : ADT-5401  
 VIN # : DW400DT605401  
 Engine Hrs In : 8691.0 Engine Hours Out : 8691.0

Part Description / Number	Qty	Sale	Ext	Labor Description	Ext
HYD OIL-STK AW-32	177.00	3.91	692.07	(1) GET SITE READY FOSTER CREEK ** SEE TECH SHEET	1,755.00
0W40 SYN OIL PER/L -STK 0W40SYN	30.00	9.26	277.80	** 1 CHANGE OVER ** ** 1 CHANGE OVER CUSTOMER SUPPLIED TIRE ** ** FOUNTAIN TIRE INVOICE 0171199224 **	384.80
MED BACK SEAT COVER -STK 350-105CK	1.00	140.00	140.00		
DOUBLE COIN REM 2 ROCK TRUCK TIRE-STK Size: 29.5R25 29.5R25	1.00	3,950.00	3,950.00		
ORING -ORDER U13639	2.00	8.72	17.44		
ORING DRIVE TRAIN -ORDER R26375	1.00	3.92	3.92		
ORING -ORDER T77858	1.00	4.93	4.93		
WASHER -ORDER 24M7055	16.00	1.26	20.16		
HANDLE -ORDER TT206439	1.00	49.37	49.37		
SEAL -ORDER TT226917	1.00	93.61	93.61		
ORING -ORDER AT252926	1.00	13.36	13.36		
8.5C U JOINT-ORDER 5-8516X	1.00	166.86	166.86		
BUMPER-ORDER AT252519	4.00	210.47	841.88		
CAP SCREW-ORDER 19M7964	16.00	3.09	49.44		
GASKET-ORDER AT257153	1.00	57.66	57.66		
CAP SCREW-ORDER TT100836	2.00	6.26	12.52		
CAP SCREW-ORDER TT100835	2.00	12.15	24.30		
WASHER-ORDER 24M7045	2.00	3.27	6.54		
REFR HOSE -ORDER AT260580	1.00	145.43	145.43		
HOSE -ORDER AT175744	2.00	40.47	80.94		

**WRENCHHEAD MECHANICAL**  
 3135 4 ST  
 NISKU, ALBERTA. T9E-8L1  
 Phone: 780-436-9570 Fax: 780- -

**INVOICE**

**40349**

Org. Est. # 057119

**INVOICE**

Printed Date: 02/02/2023 **Work Completed: 02/02/2023**

**CHEMCO-OFF ROAD**  
 3135-4 ST  
 NISKU, ALBERTA T9E-8L1  
 Office 780-436-9570

2006 JOHN DEERE - 400D 6X6 UNIT#ADT-5401 -  
 Lic # :  
 Unit # : ADT-5401  
 VIN # : DW400DT605401  
 Engine Hrs In : 8691.0  
 Odometer In : 0  
 Engine Hours Out : 8691.0

Part Description / Number	Qty	Sale	Ext	Labor Description	Ext
GASKET -ORDER AT257153	1.00	0.00	n/c		
KNOB -ORDER 843132000	1.00	38.45	38.45		
WASHER -ORDER 24M7054	2.00	0.74	1.48		
STARTER CY -ORDER TTDC221712	1.00	4,066.90	4,066.90		
50/50 LONGLIFE ANTIFREEZE-STK PREGD3000 Shop Supplies	1.50	2.98	4.47		100.00

Org. Estimate 3,664.50 Revisions 0.00 Current Estimate 3,664.50

Labor:	1,755.00
Parts:	10,859.53
Sublet:	384.80
<b>SubTotal:</b>	<b>12,999.33</b>
Tax:	649.97
<b>Total:</b>	<b>13,649.30</b>
Bal Due:	\$13,649.30

[ Payments - ]

*STK-5165*

Vehicle Received: 1/17/2023

Customer Number : 3904

GST#865376503RT0001

Signature \_\_\_\_\_ Date \_\_\_\_\_

**WRENCHHEAD MECHANICAL**

3135 4 ST  
NISKU, ALBERTA. T9E-8L1  
Phone: 780-436-9570 Fax: 780- -

REPAIR ORDER #

**040349**

Org. Est. # 057119

**REPAIR ORDER - RO**

Scheduled : 01/13/2023 04:09 PM

Print Date : 1/13/2023

**CHEMCO-OFF ROAD**

3135-4 ST  
NISKU, ALBERTA T9E-8L1  
Office 780-436-9570  
Cust ID : 3904  
Last Service : 9/9/2022

2006 JOHN DEERE - 400D 6X6 UNIT#ADT-5401 -  
Lic # : - ALBERTA  
Unit # : ADT-5401  
VIN # : DW400DT605401  
MFG Date : 5/19/2021  
Current Odom : 0

Elapsed : 0

<b>Labor Requested / Part SubTotal</b>	<b>Extended</b>
(1) GET SITE READY FOSTER CREEK	65.00
Shop Supplies	3.25
<b>Parts Subtotal</b>	<b>0.00</b>
	<b>3.25</b>

Parts: 0.00  
Labor: 65.00

Supplies: 3.25

Tax: 3.41

Total: 71.66  
Balance: 71.66

TEARDOWN ESTIMATE: I understand that my vehicle will be reassembled within \_\_\_ days of the date shown above if I choose not to authorize the service recommended. All Parts removed will be discarded unless instructed otherwise: Save all Parts \_\_\_\_. NOT RESPONSIBLE FOR LOSS OR DAMAGE TO MY VEHICLE OR ARTICLES LEFT IN VEHICLES IN CASE OF FIRE, THEFT OR ANY OTHER CAUSE. ALL VEHICLES LEFT MUST HAVE OWN INSURANCE. ANY VEHICLES LEFT OVER 30 DAYS WITHOUT CONSENT WILL BE PROPERTY OF WRENCHHEAD MECHANICAL.

Authorized By \_\_\_\_\_ Date \_\_\_\_\_ Time \_\_\_\_\_

Technician Work Sheet      Service Writer : GLAZIER, RUSSELL

Print Date: 1/13/2023

2006 JOHN DEERE - 400D 6X6 UNIT#ADT-540

Hat # :

Repair Order #

VIN # :      DW400DT605401

Color :

**040349**

Engine :

Location :

Lic # :

Lic. State : ALBERTA

**CHEMCO-OFF ROAD**

Schedule : 1/13/23 4:15 P.M.

Office 780-436-9570

Promised Date : 1/13/23 5:00 P.M.

Inspection Date :      5/19/21

Status :

Last Service :      9/09/22

Unit # : ADT-5401

Current Odometer :      0

Trans :

Previous Mileage :      0

Brakes :

Elapsed Mileage :      0

Manufacture Date : 5/19/21

**Labor Description**

**Charged Hours**

(1) GET SITE READY FOSTER CREEK

1.00

Technician : <none>

OUT ODOMETER :

Total Hours Charged :

1.00

Hours out: 0.00

**Tech Notes**

---

---

---



Unit #: ADJ-5961

S/N:

Odometer:

Hours:

Repair Description

Date

Location

Tech Name

Hours

- Install grab handle in cab. Repair glove box Reface missing heater control knob. Install removed guards to Reface leaks

Jan 25

Shop

Tracy

3

- Receive and Install U-joint. Need to run and test to confirm leak repaired. Tidy up, unit needs starter installed and to be run up and verify suction hose and drop box leak repair.

Jan 26

Shop

Tracy

1

- Install Starter, Install Shid plate. Tidy up around unit. Move outside fan check for leaks none found. Install box pads clean bay do repair work.

Jan 31

Shop

Tracy

4

8.0

Parts

Mechanic ID:

Mechanic Signature:

Qty.

Part #

Description

STK/ORD

Qty.

Part #

Description

STK/ORD





### Heavy Truck

Date: Jan 17/2023 Unit: ADT-5401 Inspector: Tracy Hours: 8691

Is a PM required within the next 100 hrs? (Yes/No) NO If yes, perform or arrange PM.

Inspection List:	Pass/Fail	Repaired (initial)	Inspection List:	Pass/Fail	Repaired (initial)
			<b>On the Machine, Outside the cab</b>		
Tires, lug nuts, rims			Fuel tank	P	
Front Hubs	P		Hydraulic oil tank	P	
Transmission Oil	P		Fire Extinguisher	P	
Front Differential	P		Windshield wipers & washers	P	
Rear Differential	P		Batteries & hold downs	P	
Underneath of machine	P		Mirrors & windows	P	
Air system	P		Weather fronts	N/A	
Steering Components	P		<b>Inside the Cab</b>		
Breaks & suspension	P		Seats	P	
Overall body, fenders & mud flaps	P		Seat belts & mounting	P	
Winch (if equipped)	N/A		Horn, back up alarm, lights, camera	P	
Park Brake	P		Gauges, indicator lights, alarms	P	
U-joints	P		Codes	P	
<b>Engine Compartment</b>			Heater & AC	P	
Engine Oil	P		Overall cab interior	P	
Engine coolant	P		Spill kit, first aid kit, flare kit	P	
Exhaust	P		Radios (AM/FM, 2-way) GPS & Antennas	P	
Air filters(engine, cab), Engine pre-cleaner	P		Decals & signage	P	
Radioator	P		Window Breaker	P	
Fuel water separator	P		Belly Tarp	N/A	
Positive air shut off	P		<b>Other</b>		
All hoses & fittings	P				
All belts	P				
Alternator output	P				
Power steering	P				
Overall engine compartment	P				

**Comments:**

Inspector Signature: [Signature] Print: Tracy

V P = Pass F = Fail R = Repaired N/A = Not Applicable

UNIT #:		ODOMETER:				ENGINE HOURS:		DATE:			
A751-540						8691		Jan 31/23			
		P	F	R	N/A			P	F	R	N/A
1	LOCKOUT IN PLACE	/				21	Transmission Oil level / Internals Fluid levels	/			
2	WHEEL CHOCKS IN PLACE	/				22	Engine Coolant & Strength	/	/		
3	Oil Samples				/	22	Engine Oil Fluid Level 0w- 40 Synthetic in Winter	/	/	/	
4	Overall Machine Loose Or Missing Nuts & Bolts, Loose Guards, Cleanliness	/				23	Radiator Debris, Damage, Leaks	/			
5	Lights Broken lamps, lenses, operation	/				24	Overall Engine Compartment Trash Or Dirt Buildup, Leaks	/			
6	Steering hydraulic system Leaks, worn hoses, damaged lines	/	/	/		25	All Hoses Cracks, Wear Spots, Leaks	/			
7	Underneath Machine Leaks, Damage, People Working	/	/	/		26	All Belts Tightness, Wear, Cracks	/			
8	Tires, rims, hub, stem caps Inflation, Leaks, Damage, Wear	/	/	/		27	Overall Cab Interior Cleanliness	/			
9	Brakes, Suspension Leaks, Damage, Wear	/				28	Roll Over Protection System Damage	/			
10	Grab Irons, Steps, Handholds Condition And Cleanliness	/				29	Gauges, lights, switches Damage, operation		/		
11	Battery Compartment Connections, Fluid level	/				30	Seat Belt, Buckle & Mounting Damage, Wear, Adjustment	/			
12	Air Filter Restriction Indicator	/				31	Seat Adjustment, Brake Travel	/			
13	Windshield Wipers & Washers Wear, Damage, Fluid Level	/				32	Horn, backup alarm, lights Proper Function	/			
14	Fill Window Washer Fluid with Winter Only	/				33	Windows and Mirrors Condition, clean, adjust	/			
15	Fuel tank, hydraulic tank Level, Leaks	/				34	Drop Box Fluids / Internals	/	/	/	
16	Body Damage, wear, distortion	/				35	Preheat Style Engine Heater and Test	/			
17	Welds, castings; mounting bolts and pads Cracks; damaged bolts or pads	/	/	/		36	SPILL KIT PROVIDED	/			
18	All Axles Leaks, Damage, Wear	/				37	Daily Inspection Booklet	/			
19	Frame & Hoist Cylinders Cracks, Leaks, Damage, Wear	/				38	FIRE EXT. CONDITION, DATE, TAG, LOCK, MOUNT	/			
20	Suspension Cylinders Leaks, Measure cylinder height	/				39	INSPECTION TAG DATE	July 2023			
						40	FIRE EXTINGUISHER #:				

√ P = Pass F = Fail R = Repaired N/A = Not Applicable

	P	F	R	N/A		P	F	R	N/A
41 Grease Gun & Grease				✓	46 Fill Diesel Tank & add Conditioner	✓			
42 Heating Operation	✓				47 Install Fuel Cap Lanyard	✓			
43 Air Conditioning Operation	✓				48 New 2 way radio	✓			
44 GPS	✓				49 Service Decal installed	✓			
45 Positive Air Shutdown & Test	✓				50				

**TIRE PRESSURE** (If not recorded on prescribed Alberta Inspection Record) [ ] psi [ ] kPa

LF:		RF:		LR:		RR:	
-----	--	-----	--	-----	--	-----	--

**CHARGING SYSTEM TEST**

VOLTS:		AMPS:		RPM:	
--------	--	-------	--	------	--

<b>FUEL LEVEL:</b>	<b>TEST / DRIVE</b>																
	TEST [ ] or TEST DRIVE [ ]																
	Comments:																
<table border="1"> <thead> <tr> <th colspan="4">CLEANING</th> </tr> <tr> <th></th> <th>Date</th> <th>Time</th> <th>Signature</th> </tr> </thead> <tbody> <tr> <td>Washed (Fine Cleaned) <input type="checkbox"/></td> <td></td> <td></td> <td></td> </tr> <tr> <td>Disinfectant Mist (Clubroot) <input type="checkbox"/></td> <td></td> <td></td> <td></td> </tr> </tbody> </table>		CLEANING					Date	Time	Signature	Washed (Fine Cleaned) <input type="checkbox"/>				Disinfectant Mist (Clubroot) <input type="checkbox"/>			
CLEANING																	
	Date	Time	Signature														
Washed (Fine Cleaned) <input type="checkbox"/>																	
Disinfectant Mist (Clubroot) <input type="checkbox"/>																	
	Technician (Print Name)																
	Technician Signature																

**MAINTENANCE REQUIRED/REMARKS:**

**INSPECTION REPORT SIGN-OFF**

 Technician (Print Name)	 Technicians Signature	 Supervisors Signature
--	--	---------------------------

<b>chemco</b>	<b>Parts Requisition</b>	<b>MTE-0130</b>
---------------	--------------------------	-----------------

UNIT #:	ADT-540d	UNIT TYPE/DESCRIPTION:	JD 4cD			
Woff	40349	ODOMETER:		ENGINE HOURS:		
					DATE:	Jan 16/11

ITEM	QTY	PART#	DESCRIPTION	IN STOCK	ORDER
	1		Tire 29.5 R25	✓	3950.00
✓	1	TT226917	Seal. T-case.		
✓	1	AT252926	O-Ring "		
✓	2	013639	O-Ring - cooler line.		
✓	<del>2</del> 1	R26375	O-Ring		
✓	1	T77858	O-Ring		
	<del>2</del> 4	AT252519	bumper (box pads)		
	<del>8</del> 16	19M7964	Belt.		
✓	16	24M7055	washer.		
✓	1	<del>AH156466.</del>	<del>steer cyl. seal kit</del>		
	1	843132000	Knob. (A/C)		
✓	1	<del>TT207437</del>	<del>Switch. (diff lock)</del>		
✓	1	<del>TT207643</del>	<del>Switch. (Range hold)</del>		
✓	1	<del>TT207652.</del>	<del>Switch. (Interior light)</del>		
✓	1	<del>TT207654</del>	<del>Switch. (head lights)</del>		
✓	1	<del>TT207651.</del>	<del>Switch. (Hazard)</del>		
	1	AT257153	oil cap gasket.		

Technician (Print Name)

Technicians Signature



P A R T S Q U O T E

BRANDT TRACTOR  
 10630-176ST  
 EDMONTON, AB T5S 1M2  
 (780) 484-6613

Date: 16 JAN 23  
 Time: 17:06  
 Expires: 15 FEB 23

For: CHEMCO ELECTRICAL CONT  
 3135 - 4 ST  
 ap@chemco.com  
 NISKU  
 (780) 436-9570

AB T9E 8L1

Slsprsn: JAN LIBOON

Quote No: 60010070095  
 Segment No: 1

*ADT 5401*

-----  
 Make JD Model NA Pin CS 000000 Segment No: 1

CHEMCO PARTS QUOTE  
 RUSS 780 306 1159

Qty	Part Number/Description	Wgt	Ext Wgt	Unit Price	Extended Price
1	TT226917 SEAL			93.61	93.61
1	AT252926 O-RING			13.36	13.36
2	U13639 O-RING			8.72	17.44
1	R26375 O-RING			3.92	3.92
1	T77858 O-RING			4.93	4.93
4	AT252519 BUMPER	2	10	194.19	776.76
16	19M7964 CAP SCREW			1.48	23.68
16	24M7055 WASHER			1.26	20.16
1	AHC16724 HYDRAULIC C			224.73	224.73
1	843132000 KNOB			38.45	38.45
1	TT207654 SWITCH			301.75	301.75
1	AT257153 GASKET			57.66	57.66
2	TT100836 CAP SCREW			6.26	12.52
1	TT206439 HANDLE			49.37	49.37
2	TT100835 CAP SCREW			7.06	14.12
2	24M7054 WASHER			.74	1.48
6	AT342997 BUSHING	20	120	1049.67	6298.02
3	AT433819 ISOLATOR	45	136	2736.18	8208.54
	Total Weight		268		

Total Labor 0.00  
 Total Parts 16160.50  
 Total Misc 0.00

Customer may be subject to GST/HST

Quote/Estimate Expires: 15 FEB 23

Taxes 0.00  
 Grand Total 16160.50

# Shopping Cart(22)



ADT-5401

Part	Quantity
Seal Part Number: TT226917	1
O-Ring Part Number: AT252926	1
O-Ring Part Number: U13639	2
O-Ring Part Number: R26375	1
O-Ring Part Number: T77858	1
Bumper Part Number: AT252519	4
Cap Screw Part Number: 19M7964	16
Washer Part Number: 24M7055	16

Part	Quantity
Hydraulic Cylinder Kit Part Number: AHC16724  This part substitutes for AH156466	1
KNOB - Part Number: 843132000	1
Switch Part Number: TT207437	1
Switch Part Number: TT207643	1
Switch Part Number: TT207652	1
Switch Part Number: TT207654	1
Switch Part Number: TT207651	1
Gasket Part Number: AT257153	1
Cap Screw Part Number: TT100836	2

Part	Quantity
Handle Part Number: TT206439	1
Cap Screw Part Number: TT100835	2
Washer Part Number: 24M7054	2
<del>Bushing</del> Part Number: <del>AT342997</del>	6
Isolator Part Number: AT433819	3
 This part substitutes for AT195217	



Brandt Tractor Ltd.  
10630 176+th St.  
Edmonton, AB  
T5S 1M2  
(780) 484-6613

Parts  
Invoice



JOHN DEERE

S  
O  
L  
D  
T  
O

CHEMCO ELECTRICAL CONT  
3135 - 4 ST  
ap@chemco.com  
NISKU AB T9E 8L1 CA

PAGE		
1		
CASH	CHG.	OTHER
	X	
ACCOUNT NO.		

S  
H  
I  
P  
T  
O

CHEMCO ELECTRICAL CONT  
PO # REQUIRED ON  
PICKUP WHAT IS AV  
*40349-AOT 5401*

SALESMAN	ORDER NO.	RO. NO.	PHONE	INVOICE DATE	TIME	INVOICE NO.
823	SEE BELOW	01662360	)	21JAN23	18:15	06 4684788

QUANTITIES				PART NUMBER	DESCRIPTION	BIN	PRICES			OFFICE USE
ORDERED	SHIPPED	B/O	✓				LIST	NET	EXTENSIONS	
	<i>4</i>			MAKE: JD	MODEL:	SERNO:			HRS:	
	<i>16</i>			N AT252519	BUMPER	CY	210.47	210.47	841.88	PC
	<i>1</i>			N 19M7964	CAP SCRECY		3.09	3.09	49.44	PC
	<i>2</i>			N AT257153	GASKET	CY	57.66	57.66	57.66	PC
	<i>2</i>			N TT100836	CAP SCRECY		6.26	6.26	12.52	PC
	<i>2</i>			N TT100835	CAP SCRECY		12.15	12.15	24.30	PC
	<i>2</i>			N 24M7045	WASHER	CY	3.27	3.27	6.54	PC
Tax ID: EDMONTON C&F PARTS DEPARTMENT HOURS: OPEN MONDAY - THURSDAY 6AM TO 12AM OPEN FRIDAY 6AM - 9PM OPEN SATURDAY & SUNDAY 6AM - 7PM CLOSED ON STAT HOLIDAYS ALL OPENED ELECTRICAL PARTS ARE NON-RETURNABLE ALL SPECIAL ORDERED PARTS ARE SUBJECT TO 15% RESTOCK CHARGES. AS OF APRIL 1, 2022 ALL RETURNS REQUIRE A COPY OF PURCHASE PAPERWORK										
SIGNATURE JAN 24 2023 PRINT NAME										
				GST No. 899544779					49.62	
				* TOTAL GST/HST *						

QST # 1226957240

PICKUP

SHIP VIA

TERMS: NET 30 DAYS FROM  
DATE OF INVOICE

NO GOODS CAN BE RETURNED WITHOUT OUR PERMISSION. GOODS RETURNED BY PERMISSION WHICH WERE FURNISHED CORRECTLY ACCORDING TO ORDER ARE SUBJECT TO A HANDLING CHARGE. NO CLAIMS ON THIS INVOICE WILL BE CONSIDERED AFTER 30 DAYS OF RECEIPT OF GOODS.

PAST DUE INTEREST 1 1/2% PER MONTH (18% ANNUM).  
MINIMUM CHARGE OF \$1.50

TITLES TO ALL ITEMS REMAIN WITH BRANDT TRACTOR LTD. UNTIL PURCHASE PRICE, INTEREST AND OTHER CHARGES ARE FULLY PAID.

DESCRIPTION	ACCOUNT	AMOUNT
PARTS TAXABLE		
PARTS NONTAXBLE		992.34
MISC TAXABLE		
MISC NONTAXABLE		
SALES TAX		
PLEASE PAY THIS TOTAL		1041.96

SIGNATURE \_\_\_\_\_

DATE \_\_\_\_\_

UNIT #:	ADT 5401	UNIT TYPE/DESCRIPTION:	400D		
W.O.#	40349	ODOMETER:	ENGINE HOURS:	DATE:	Jan 25

ITEM	QTY	PART#	DESCRIPTION	IN STOCK	ORDER
	1	TTDC227112	Starter		
	1		Starter gasket		
		SE 502410			4066.00
		SOL			
		TTDC 221716			1124.29
			Jan 25-23		
			4:30 pm		
			/		

*Tracy*  
Technician (Print Name)

Technicians Signature



FOUNTAIN TIRE (LEDUC) LTD.

7126 SPARROW DR  
LEDUC AB T9E 8A5

# Invoice

Order Number: 017SWO00214672  
Service Contact: CHRISTOPHER WILLIAM

Phone: 780.980.0000  
Fax 780.986.1786  
F017@FOUNTAIN TIRE.COM  
856181748RT0001

Date: 20/01/2023  
Invoice: 0171199224  
PO#: ADT5401  
AirMiles # :  
Terms of payment Net\_30

**Bill to Customer**

**Ship to Customer:**

CHEMCO ELECTRICAL CONTRACTORS L'  
3135 4 ST  
NISKU AB T9E 8L1

CHEMCO ELECTRICAL CONTRACTORS L'  
3135 4 ST  
NISKU AB T9E 8L1

Year: NA Unit: ADT5401  
Make: JOHN DEERE  
Model: OTHER OTR  
Design:  
Engine:  
License: Colour:  
Vin: DW400DT605401  
Mileage: 0 Hours: 0

Item number	Item description	Qty	Unit price	Total
<b>OTR Tires, Wheels and Service</b>				
TSC0521	C/O Dry OTR 29.5 x 25 (875/65R29)	1.00	\$173.50	\$173.50
<b>Tire and Wheel Parts / Hardware</b>				
ORING	OTR ORING	1.00	\$18.95	\$18.95
<b>Service Call</b>				
FUEL	Fuel Surcharge	1.00	\$25.00	\$25.00
SC031	YARD - Service Call	1.00	\$150.00	\$150.00
<b>Other Miscellaneous Items</b>				
SHOP	Shop Supplies	1.00	\$17.35	\$17.35

Customer requirements

PURCHASE ORDER #	ADT5401
TRAILER #	NA
ODOMETER/HUBDOMETER	NA
LIC # & STATE	NA
VEH/FLEET/TRLR/UNIT #	ADT5401

*FILE*

Air Miles: 0

**Invoice comment**

Refer to work order 029880  
January.20/2023  
Replaced one tire with customer supplied on RR - scrapped old due to tire having bulge  
Service done at customers shop

I acknowledge: (1) receipt of goods and services; and (2) Fountain Tire may conduct a registry search to verify the VIN on my vehicle if required for collection purposes on unpaid invoices related to my vehicle.

The customer is to ensure all wheel lugs are re torqued by a qualified technician before the vehicle has travelled 100 kilometers.

Parts:	\$18.95
Services:	\$365.85
Sub Total:	\$384.80
GST:	\$19.24
<b>Total: (CAD)</b>	<b>\$404.04</b>

Pay type: CFA \$404.04

Please Remit Payment to:

Fountain Tire Ltd.  
Fountain Tire Place  
#301 - 1006-103A Street SW  
Edmonton, Alberta T6W 2P6

X \_\_\_\_\_

**WRENCHHEAD MECHANICAL**

3135 4 ST  
 NISKU, ALBERTA. T9E-8L1  
 Phone: 780-436-9570 Fax: 780- -

*KW*

**INVOICE**

**38812**

**INVOICE**

Printed Date: 09/09/2022 Work Completed: 09/09/2022

**CHEMCO-OFF ROAD**  
 3135-4 ST  
 NISKU, ALBERTA T9E-8L1  
 Office 780-436-9570

2006 JOHN DEERE - 400D 6X6 UNIT#ADT-5401 -  
 Lic # : Odometer In : 0  
 Unit # : ADT-5401  
 VIN # : DW400DT605401

Part Description / Number	Qty	Sale	Ext	Labor Description	Ext
ORING -ORDER AT252928	2.00	17.09	34.18	(1) PARTS ONLY - RICHARD	n/c
ORING -ORDER U43360	2.00	13.06	26.12		
SHAFT -ORDER TT224449	1.00	5,741.15	5,741.15		
SCREW -ORDER 19M8169	4.00	6.09	24.36		
SEAL -ORDER TT226917	1.00	86.31	86.31		
HYD PUMP -ORDER PG200344	1.00	1,638.70	1,638.70		
ORING -ORDER AT252926	1.00	11.97	11.97		
CAP SCREW -ORDER 19H3836	8.00	11.67	93.36		
FILTER -ORDER TT222219	1.00	29.69	29.69		
ORING -ORDER R460R	1.00	6.91	6.91		
ORING -ORDER A49065	1.00	5.17	5.17		

Org. Estimate 8,082.82 Revisions 0.00 Current Estimate 8,082.82

Labor:	0.00
Parts:	7,697.92
SubTotal:	7,697.92
Tax:	384.90
Total:	8,082.82
Bal Due:	\$8,082.82

[ Payments - ]

Vehicle Received: 9/9/2022

Customer Number : 3904

GST#865376503RT0001

Signature \_\_\_\_\_ Date \_\_\_\_\_

DEERE 4000

Unit #: ADT-5401      SIN #:      Odometer:      Hours: 84460

Lab #	Repair Description	Date	Location	Tech Name	Hours
	- Cleaned off Old Pump and switched over Section and Discharge Manifold Block. Set up and pulled Tractor bearing races off of idler bear shaft, went over and prepared surfaces to be installed.	July 27 2020	ST-Paul Shop	Richard Corbier	5hrs
	- Installed Idler bear in drop box. Re-sealed, mounted Pump (Secondary steering). Installed Hyd lines, mounted drop box. Lubed Pumps and filter housing. Filled drop box with 10W Oil. Re-sealed front yoke output seals. And installed Drive shaft. back tightened bolts. Packed up. Test run around the yard, worked Air out of the system.	July 28 2022	ST-Paul Shop	Richard Corbier	10.5hrs

Parts

Mechanic ID:		Mechanic Signature: Richard Corbier			
Qty	Part #	Description	STK/ORD	Returns	
		- Parts from Westlake Tractor Parts (Rob)			
		- Brent Tractor we picked up at Cheraco			





**WRENCHHEAD MECHANICAL**

3135 4 ST  
 NISKU, ALBERTA. T9E-8L1  
 Phone: 780-436-9570 Fax: 780- -

**INVOICE****37221**

Org. Est. # 053981

**INVOICE**

Date: 01/21/2022

**CHEMCO-OFF ROAD**

3135-4 ST  
 NISKU, ALBERTA T9E-8L1  
 Office 780-436-9570

2006 JOHN DEERE - 400D 6X6 UNIT#ADT-5401 -

Lic # :  
 Unit # : ADT-5401  
 VIN # : DW400DT605401  
 Engine Hrs In : 8376.0

Odometer In : 0

Engine Hours Out : 8376.0

Part Description / Number	Qty	Sale	Ext	Labor Description	Ext
24V ENGINE HEATER -STK GC0072	1.00	695.00	695.00	(1) INSPECTION, GET SITE READY FOSTER CREEK ** PERFORM HEART LAKE CHECK LIST **	2,925.00
4.5" 24V INTERNALLY SWITCHED POS -ORDER PASS-4500	1.00	1,345.28	1,345.28	** INSTALL POS SYSTEM ** ** INSTALL 24V COOLANT HEATER ** ** REPAIR GPS FOR NO SIGNAL **	
3/8" SILICONE HEATER HOSE/FT-STK 5526-038	0.50	3.85	1.93	** DIAGNOSE NO LIGHTS, REPLACE CIRCUIT BREAKER ** ** INSTALL 2 WAY **	
5/8" HOSE SPLICER -STK 129-10	3.00	0.81	2.43		
5/8" HEATER HOSE /FT -STK 65031	5.00	2.52	12.60		
3/4" HEATER HOSE/FT 65033	1.00	3.36	3.36		
1/4" SPLIT LOOM /FT Size: 1/4" 76-9870CRL	20.00	0.25	5.00		
3/8" SPLIT LOOM /FT -STK Size: 3/8" 806S-1	25.00	0.28	7.00		
H4 HEADLIGHT-STK H4	1.00	8.66	8.66		
CIRCUIT BREAKER-ORDER AT252547	1.00	129.80	129.80		
HAMMER -ORDER 4362700	1.00	26.48	26.48		
BRACKET -STK 2038764	1.00	18.22	18.22		
SPILL KIT BAG-STK RTXSK002	1.00	34.99	34.99		
Shop Supplies			100.00		

**WRENCHHEAD MECHANICAL**

3135 4 ST  
NISKU, ALBERTA. T9E-8L1  
Phone: 780-436-9570 Fax: 780- -

**INVOICE**

**37221**

Org. Est. # 053981

**INVOICE**

Date: 01/21/2022

**CHEMCO-OFF ROAD**  
3135-4 ST  
NISKU, ALBERTA T9E-8L1  
Office 780-436-9570

2006 JOHN DEERE - 400D 6X6 UNIT#ADT-5401 -  
Lic # : Odometer In : 0  
Unit # : ADT-5401  
VIN # : DW400DT605401  
Engine Hrs In : 8376.0 Engine Hours Out : 8376.0

Part Description / Number	Qty	Sale	Ext	Labor Description	Ext
---------------------------	-----	------	-----	-------------------	-----

Org. Estimate 1,699.19 Revisions 0.00 Current Estimate 1,699.19

Labor:	2,925.00
Parts:	2,390.75
SubTotal:	5,315.75
Tax:	265.79
Total:	5,581.54
Bal Due:	\$5,581.54

*STK - 889*

[ Payments - ]  
Vehicle Received: 1/13/2022

Customer Number : 3904

GST#865376503RT0001

Signature \_\_\_\_\_ Date \_\_\_\_\_

**WRENCHHEAD MECHANICAL**

3135 4 ST  
NISKU, ALBERTA. T9E-8L1  
Phone: 780-436-9570 Fax: 780- -

REPAIR ORDER #

**037221**

Org. Est. # 053981

**REPAIR ORDER - RO**

Scheduled : 01/11/2022 01:27 PM

Print Date : 1/11/2022

**CHEMCO-OFF ROAD**

3135-4 ST  
NISKU, ALBERTA T9E-8L1  
Office 780-436-9570  
Cust ID :  
Last Service : 10/7/2021

2006 JOHN DEERE - 400D 6X6 UNIT#ADT-5401 -

Lic # : - ALBERTA

Unit # : ADT-5401

VIN # : DW400DT605401

MFG Date : 5/19/2021

Current Odom : 0

Elapsed : 0

**Labor Requested / Part SubTotal**

**Extended**

(1) INSPECTION, GET SITE READY FOSTER CREEK

260.00

**Parts Subtotal 0.00**

Shop Supplies

13.00

**Parts: 0.00**  
**Labor: 260.00**

**Supplies: 13.00**

**Tax: 13.65**

**Total: 286.65**  
**Balance: 286.65**

TEARDOWN ESTIMATE: I understand that my vehicle will be reassembled within \_\_\_ days of the date shown above if I choose not to authorize the service recommended. All Parts removed will be discarded unless instructed otherwise: Save all Parts \_\_\_\_. NOT RESPONSIBLE FOR LOSS OR DAMAGE TO MY VEHICLE OR ARTICLES LEFT IN VEHICLES IN CASE OF FIRE, THEFT OR ANY OTHER CAUSE. ALL VEHICLES LEFT MUST HAVE OWN INSURANCE. ANY VEHICLES LEFT OVER 30 DAYS WITHOUT CONSENT WILL BE PROPERTY OF WRENCHHEAD MECHANICAL.

Authorized By \_\_\_\_\_ Date \_\_\_\_\_ Time \_\_\_\_\_



Technician Work Sheet      Service Writer : GLAZIER, RUSSELL

Print Date: 1/11/2022

2006 JOHN DEERE - 400D 6X6 UNIT#ADT-540

Hat # :

Repair Order #

VIN # : DW400DT605401

Color :

037221

Engine :

Location :

Lic # :

Lic. State : ALBERTA

**CHEMCO-OFF ROAD**

Office 780-436-9570

Schedule : 1/11/22 1:30 P.M.

Promised Date : 1/11/22 5:00 P.M.

Inspection Date : 5/19/21

Status :

Last Service : 10/07/21

Unit # : ADT-5401

Current Odometer : 0

Trans :

Previous Mileage : 0

Brakes :

Elapsed Mileage : 0

Manufacture Date : 5/19/21

**Labor Description**

**Charged Hours**

(1) INSPECTION, GET SITE READY FOSTER CREEK

4.00

Technician : <none>

OUT ODOMETER :

8376H

Total Hours Charged :

4.00

Hours out: 0.00

**Tech Notes**

---



---



---

Unit #: ADT-5401

S/N:

Odometer:

Hours: 8376

#1

Lab#	Repair Description	Date	Location	Tech Name	Hours
	START UNIT / BRING UP TO SHOP / MAKE LABOR & PARTS LIST	JAN 11/22	yard	DANNYL M	2
	Measured location for positive air Tapped up washer fluid & checked fire extinguisher diagnosed fuel gauge	Jan 17/22	shop	DShaw	2
	INSTALL ENGINE HEATER / BUILD MOUNTING BRACKET	JAN 14/22	SHOP	DANNYL M	3
	DIAG GPS INOP / REWIRE / RUN FUEL LINES FOR ENGINE HEATER / PLUMB IN DICKUP / MOUNT HEATER CONTROLLER / WIRE IN PAS / RUN POWER WIRES FOR PAS + ENGINE HEATER / TEST OPERATION	JAN 17/22	SHOP	DANNYL M	10
1 →	Start Plumbing in Heater Hose Lines and water pump and Fittings → finish plumbing in coolant Heater and started to diagnose other problems. added diesel fuel conditioner	Jan 17, 22	shop	Brent Garcia.	11h
					28.0

Parts

Mechanic ID:

Mechanic Signature:

Qty.	Part #	Description	STK/ORD	Qty.	Part #	Description	STK/ORD
1/2 foot	5526-038	3/8 Heater Hose	STK	1		SHOCKER PAS	✓
2	PMAH-4	5/8 od SS Gear clamp	STK.	1		ENGINE HEATER	✓
1	129-10	5/8 male to 5/8 male.	STK				
5 Feet	65031	Heater Hose 5/8.	STK				
1 Foot	65033	Heater Hose 3/4	STK				
20 feet	76-9870RL	1/4 od split Loom 1/4	STK				
25 feet	8065-L	3/8 split Loom 3/8	STK				
x1	P43+27342	MV 24V Head Light	STK.				



√ P = Pass F = Fail R = Repaired N/A = Not Applicable

UNIT #:		ODOMETER:				ENGINE HOURS:		DATE:			
ADT-5401						8376		Jan 12/22			
		P	F	R	N/A			P	F	R	N/A
1	LOCKOUT IN PLACE				✓	21	Transmission Oil level / Internals Fluid levels	✓			
2	WHEEL CHOCKS IN PLACE				✓	22	Engine Coolant Fluid Level	✓			
3	Oil Samples				✓	22	Engine Oil Fluid Level	✓			
4	Overall Machine Loose Or Missing Nuts & Bolts, Loose Guards, Cleanliness	✓				23	Radiator Debris, Damage, Leaks	✓			
5	Lights Broken lamps, lenses, operation	✓				24	Overall Engine Compartment Trash Or Dirt Buildup, Leaks	✓			
6	Steering hydraulic system Leaks, worn hoses, damaged lines	✓				25	All Hoses Cracks, Wear Spots, Leaks	✓			
7	Underneath Machine Leaks, Damage, People Working	✓				26	All Belts Tightness, Wear, Cracks	✓			
8	Tires, rims, hub, stem caps Inflation, Leaks, Damage, Wear	✓				27	Overall Cab Interior Cleanliness	✓			
9	Brakes, Suspension Leaks, Damage, Wear	✓				28	Roll Over Protection System Damage	✓			
10	Grab Irons, Steps, Handholds Condition And Cleanliness	✓				29	Gauges, lights, switches Damage, operation	✓			
11	Battery Compartment Connections, Fluid level	✓				30	Seat Belt, Buckle & Mounting Damage, Wear, Adjustment	✓			
12	Air Filter Restriction Indicator	✓				31	Seat Adjustment, Brake Travel	✓			
13	Windshield Wipers & Washers Wear, Damage, Fluid Level	✓				32	Horn, backup alarm, lights Proper Function	✓			
14	Fire Extinguisher Charge, Damage	✓				33	Windows and Mirrors Condition, clean, adjust	✓			
15	Fuel tank, hydraulic tank Level, Leaks	✓				34	Drop Box Fluids / Internals	✓			
16	Body Damage, wear, distortion	✓				35	Preheat / Block Heater	✓			
17	Welds, castings; mounting bolts and pads Cracks; damaged bolts or pads	✓				36	SPILL KIT PROVIDED	✓			
18	All Axles Leaks, Damage, Wear	✓				37	Daily Inspection Booklet	✓			
19	Frame & Hoist Cylinders Cracks, Leaks, Damage, Wear	✓				38	FIRE EXT. CONDITION, DATE, TAG, LOCK, MOUNT	✓			
20	Suspension Cylinders Leaks, Measure cylinder height	✓				39	INSPECTION TAG DATE	July 6/22			
						40	FIRE EXTINGUISHER #:	32205			

√ P = Pass    F = Fail    R = Repaired    N/A = Not Applicable

		P	F	R	N/A			P	F	R	N/A
41	Grease Gun & Gease				✓	43	Air Conditioning Operation	✓			
42	Heating Operation	✓				44	GPS				

<b>TIRE PRESSURE</b> (If not recorded on prescribed Alberta Inspection Record)				[ ✓ ]	psi	[ ]	kPa
LF:	60	RF:	60	LR:	60	RR:	60

<b>CHARGING SYSTEM TEST</b>							
VOLTS:	25	AMPS:	110	RPM:	1200		

<b>FUEL LEVEL:</b> <i>Full</i>	<b>TEST / DRIVE</b>																	
	TEST [ ✓ ]	or TEST DRIVE [ ]																
Comments:																		
<table border="1" style="width:100%; border-collapse: collapse;"> <thead> <tr> <th colspan="4">CLEANING</th> </tr> <tr> <th></th> <th>Date</th> <th>Time</th> <th>Signature</th> </tr> </thead> <tbody> <tr> <td>Washed (Fine Cleaned)</td> <td><input type="checkbox"/></td> <td></td> <td></td> </tr> <tr> <td>Disinfectant Mist (Clubroot)</td> <td><input type="checkbox"/></td> <td></td> <td></td> </tr> </tbody> </table>			CLEANING					Date	Time	Signature	Washed (Fine Cleaned)	<input type="checkbox"/>			Disinfectant Mist (Clubroot)	<input type="checkbox"/>		
CLEANING																		
	Date	Time	Signature															
Washed (Fine Cleaned)	<input type="checkbox"/>																	
Disinfectant Mist (Clubroot)	<input type="checkbox"/>																	
	<i>Darryl MATCHEM</i> Technician (Print Name)	 Technician Signature																

<b>MAINTENANCE REQUIRED/REMARKS:</b> <i>NEXT SERVICE DUE @ 8862</i>
--

<b>INSPECTION REPORT SIGN-OFF</b>		
<i>Darryl MATCHEM</i> Technician (Print Name)	 Technicians Signature	  Supervisors Signature



### Heavy Truck

Date: JAN 12/22 Unit: ADT-340 Inspector: DANNYL MATCHEM Hours: 8376

Is a PM required within the next 100 hrs? (Yes/No) (No) If yes, perform or arrange PM.

Inspection List:	Pass/Fail	Repaired (initial)	Inspection List:	Pass/Fail	Repaired (initial)
<b>On the Machine, Outside the cab</b>					
Tires, lug nuts, rims	P		Fuel tank	P	
Front Hubs	P		Hydraulic oil tank	P	
Transmission Oil	P		Fire Extinguisher	P	
Front Differential	P		Windshield wipers & washers	P	
Rear Differential	P		Batteries & hold downs	P	
Underneath of machine	P		Mirrors & windows	P	
Air system	P		Weather fronts	NA	
Steering Components	P		<b>Inside the Cab</b>		
Breaks & suspension	P		Seats	P	
Overall body, fenders & mud flaps	P		Seat belts & mounting	P	
Winch (if equipped)	NA		Horn, back up alarm, lights, camera	P	
Park Brake	P		Gauges, indicator lights, alarms	P	
U-joints	P		Codes	P	
<b>Engine Compartment</b>			Heater & AC	P	
Engine Oil	P		Overall cab interior	P	
Engine coolant	P		Spill kit, first aid kit, flare kit	P	
Exhaust	P		Radios (AM/FM, 2-way) GPS & Antennas	P	
Air filters(engine, cab), Engine pre-cleaner	P		Decals & signage	P	
Radioator	P		Window Breaker		
Fuel water separator	P		Belly Tarp	NA	
Positive air shut off	P		<b>Other</b>		
All hoses & fittings	P				
All belts	P				
Alternator output	P				
Power steering	P				
Overall engine compartment	P				

Comments:

Inspector Signature: \_\_\_\_\_ Print: \_\_\_\_\_

# HEADWATER EQUIPMENT

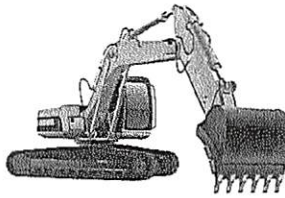

PARTS: Ph:  
Fx:  
  
SALES: Ph:  
Fx:  
  
SHOP: Ph:  
Fx:

18104, 111 Ave NW, Edmonton, AB, T5S 2H4

SOLD TO  
CHEM00 CHEMCO ELECTRICAL CONTRACTOR  
3135 4TH STREET  
NISKU, AB T9E 8L1

SHIP TO  
CHEMCO. ATTN RYAN CHAPPELL  
HOLD FOR PICK UP

Sold By: MORH PO #: ADI-540E Date 9/01/21 COUNTER INVOICE IE60142  
Ship By: Tax #: 21:57:47

Tax	D	Qty	Description	Price	Amount
			PARTS COUNTER		
T		1	MIS TT210853	8400.00	8400.00
			GST CONTROL VAL		
T			FREIGHT		
			GST INCOMING FREIGHT @ 165LBS		237.00

VALVE ID PLATE NO'S:  
3767288  
210362  
0249758541-002  
USED & INSPECTED. 30 DAY WARRANTY.  
PICKED UP BY CHEMCO SEPT 1/21

Returned goods will not be accepted unless by prior arrangement and accompanied by this invoice; NO returns after 30 days, returns may be subject to a 15% restocking charge  
All manufacturers names, numbers, and descriptions are used for reference purposes and it is not implied that any part listed is the product of these manufacturers.

TERMS: Net 30 Days - a service charge of 2% per month (24% per annum) will be charged on all overdue accounts.

By signing below you acknowledge and accept the above terms and conditions.

\*\* SUBTOTAL 8637.00

\*\* GST 431.85

X \_\_\_\_\_ Charge Sale

PAY THIS  
AMOUNT

\$9068.85

**WRENCHHEAD MECHANICAL**

3135 4 ST  
 NISKU, ALBERTA. T9E-8L1  
 Phone: 780-436-9570 Fax: 780- -

**INVOICE**

**35329**

Org. Est. # 052082

**INVOICE**

Ref #: 8362 HOURS

Date: 08/17/2021

**CHEMCO-OFF ROAD**  
 3135-4 ST  
 NISKU, ALBERTA T9E-8L1  
 Office 780-436-9570

2006 JOHN DEERE - 400D 6X6 UNIT#ADT-5401 -  
 Lic # :  
 Unit # : ADT-5401  
 VIN # : DW400DT605401  
 Engine Hrs In : 8362.0  
 Odometer In : 0  
 Engine Hours Out : 8362.0

Part Description / Number	Qty	Sale	Ext	Labor Description	Ext
SYNTHETIC 5W40 OIL-STK 5W40SYN	35.00	5.50	192.50	(1) INSPECTION	9,392.50
OIL SAMPLE JAR-STK 3202711103-50	11.00	23.83	262.13		
75W90 SYNTHETIC GEAR OIL-STK 75W90SYN	123.00	8.14	1,001.22		
BRAKE PAD -ORDER TT226224X	1.00	488.60	488.60		
FUEL FILTER-ORDER TTDC221512	1.00	38.32	38.32		
T-CASE FILTER-ORDER TT222219	1.00	22.13	22.13		
BRAKE FILTER-ORDER TT220736	2.00	222.75	445.50		
FUEL FILTER-ORDER RE171321	1.00	21.83	21.83		
HYD FILTER-ORDER AT498275	1.00	25.92	25.92		
HYD FILTER-ORDER TTT222389	1.00	203.07	203.07		
TRANS FILTER KIT-ORDER AT357236	2.00	159.08	318.16		
CHEMCO DOOR DECAL-STK CD	2.00	8.50	17.00		
FIRE EXT. BRACKET-STK ASF30937	1.00	70.58	70.58		
ENGINE OIL FILTER-ORDER TTDC221513	1.00	38.80	38.80		
O-RING-ORDER L151416	2.00	8.82	17.64		
FUEL FILTER-ORDER AT257354	1.00	25.54	25.54		
CABIN FILTER-ORDER TT226019	1.00	128.92	128.92		
FILTER-ORDER AT411898	1.00	241.58	241.58		
BRAKE OIL GAUGE-ORDER TT217421	1.00	228.10	228.10		
KNOB-ORDER TT226932	1.00	62.39	62.39		
BELT-ORDER	1.00	257.47	257.47		

CAP

STK 2949

**WRENCHHEAD MECHANICAL**

3135 4 ST  
 NISKU, ALBERTA. T9E-8L1  
 Phone: 780-436-9570 Fax: 780- -

**INVOICE**

**35329**

Org. Est. # 052082

**INVOICE**

Ref #: 8362 HOURS

Date: 08/17/2021

**CHEMCO-OFF ROAD**  
 3135-4 ST  
 NISKU, ALBERTA T9E-8L1  
 Office 780-436-9570

2006 JOHN DEERE - 400D 6X6 UNIT#ADT-5401 -  
 Lic #: Odometer In : 0  
 Unit #: ADT-5401  
 VIN #: DW400DT605401  
 Engine Hrs In : 8362.0 Engine Hours Out : 8362.0

Part Description / Number	Qty	Sale	Ext	Labor Description	Ext
TTDC221514				* FIRE UP UNIT AND BRING INTO SHOP	
STEREO DECK-STK	1.00	118.99	118.99	* INSPECT LABOR AND PARTS QUOTE	
313-KD-X37MBS				* GOT QUOTE BACK AND WAS TOLD TO NOT REPAIR MANY THINGS	
UHF RADIO-STK	1.00	375.00	375.00	* MOVE TO WASH BAY AND FLIP CAP DROP PANS	
TK8302HK2				* LOWER CAB PIN STUMP PAN	
ANTENNA-ORDER	1.00	224.11	224.11	* BRING UNIT BACK INTO SHOP	
TT266748				* RE-GLUG REAR WINDOW, AND REPLACED WINDOW LATCHES	
WIPER-ORDER	1.00	45.27	45.27	* REMOVE FOGGY HEAD LIGHT, GLUE CRACK AND CLEAN LENS	
TT217618				* INSTALL CHEMCO DECALS AND FIRE EXT BRACKET (WE ARE OUT OF FIRE EXT MAY 25)	
PRIMARY AIR FILTER-ORDER	1.00	169.58	169.58	* REPAIR RIGHT STEP	
AH170798				* INSTALL BATTERY HOLD DOWNS	
SECONDARY AIR FILTER-ORDER	1.00	124.42	124.42	* DIAG AIR SEAT. UNIT DID NOT ORIGINALLY COME WITH AIR SEAT. PREVIOUS OWNER RAN WIRE FROM FUSE BOX AND GROUND TO FRAME. PLUG WIRE BACK INTO FUSE BOX. AIR SEAT WORKS BUT THE REPAIR JOB FROM OWNER IS NOT VERY GOOD.	
TT221378				* TROUBLE SHOOT LIGHT ISSUE	
GASKET-ORDER	1.00	59.82	59.82	* SERVICE ALL 3 DIRTS. DRAINED OIL AND FILLED. OIL SAMPLE	
TTDC221650				* MONITORING OIL FROM FRONT LEFT FINAL DRIVE AND MIDRIGHT LOTS OF FINE METAL IN OIL	
GASKET-ORDER	5.00	63.71	318.55	* REMOVE AND REPLACE AIR FILTERS AND CLEAN HOUSING OUT	
TTDC221651				* CHANGED OIL AND OIL FILTER	
PIN-ORDER	1.00	92.00	92.00	* CHANGED BOTH FUEL FILTERS	
TT181860				* DRAIN BRAKE OIL TANK, FILTERS AND CHANGE LEAKING SIGHT GLASS. INSTALLED NEW BRAKE OIL TANK. FILLED BRAKE OIL TANK. INSTALLED 4 BRAKE DRAIN PLUGS FOR HOUSING	
HYD OIL-STK	293.50	2.30	675.05	* CHANGED HYD BREATHER ON HYD TANK. FILTER BLOWN APART AS WELL AS HOUSING. DRAINED TANK AND TOOK OIL SAMPLE. FILLED HYD TANK	
AW-32				* DRAINED TRANSMISSION OIL AND TOOK OIL SAMPLE. REPLACE BOTH TRANS FILTERS AND FILL TRANS OIL	
HINGE-ORDER	4.00	20.24	80.96	* CHANGED CAB FILTER	
TT277487				* DRAINED TRANSFER CASE. DAMAGED PLUG. REPLACED. FILLED TRANSFER CASE	
CATCH-ORDER	1.00	192.32	192.32	* DRAINED BOTH FRONT STEER WHEELS AND BOTH MIX AXLE WHEELS	
TT221628				* REPLACED DOORKNOB IN CAB	
BREATHER-ORDER	3.00	44.86	134.58	* STARTED REMOVING OPERATOR STATION LABELING TO REPLACE AM/FM ANTENNA AND PARK BRAKE CONTROL	
AT253791				* REMOVE DRIVE AXLE 2 FILL PLUG AND INSTALL NEW ONE THAT WAS ORDERED	
EXH FILTER-ORDER	1.00	54.74	54.74	* REMOVE AND REPLACE HINGE ON THE D/S FRONT BATTERY SHUT OFF BOX	
TT226348				* REMOVED AND INSTALLED REMAINING GUARDS AND FAN BELT * REMOVE PANELS FOR PARK BRAKE SWITCH REPLACEMENT	
EXH FILTER-ORDER	1.00	39.79	39.79	* REMOVE STEREO (NOT WORKING) TO GET AM/FM ANTENNA REPLACED. WIRE IN 2 WAY RADIO AND NEW AM/FM RADIO	
TT226349					
PARK BRAKE VALVE-ORDER	1.00	1,461.18	1,461.18		
TT210534					
DRAIN PLUG-ORDER	1.00	56.85	56.85		
TT207660					
O-RING-ORDER	1.00	34.00	34.00		
4203184					
HYD FILTER HOUSING-ORDER	1.00	1,692.40	1,692.40		
TT210862					
DRAIN-ORDER	1.00	129.15	129.15		
AT211196					

**WRENCHHEAD MECHANICAL**

3135 4 ST  
 NISKU, ALBERTA. T9E-8L1  
 Phone: 780-436-9570 Fax: 780- -

**INVOICE**

**35329**

Org. Est. # 052082

**INVOICE**

Ref #: 8362 HOURS

Date: 08/17/2021

**CHEMCO-OFF ROAD**  
 3135-4 ST  
 NISKU, ALBERTA T9E-8L1  
 Office 780-436-9570

2006 JOHN DEERE - 400D 6X6 UNIT#ADT-5401 -  
 Lic # : Odometer In : 0  
 Unit # : ADT-5401  
 VIN # : DW400DT605401  
 Engine Hrs In : 8362.0 Engine Hours Out : 8362.0

Part Description / Number	Qty	Sale	Ext	Labor Description	Ext
CAP-ORDER TT207967	1.00	8.02	8.02	* INSTALLED GPS AND RE INSTALL PANELS AND SECURE LOOSE WIRING BEHIND GAUGE CLUSTER	
T-CASE PLUG-ORDER 15M7077	1.00	17.08	17.08	* STARTED REMOVING PARK BRAKE AIR LINES * REMOVE PARK BRAKE CONTROLLER AND INSTALLED NEW ONE	
WINDOW CATCH-ORDER TT221627	1.00	192.96	192.96	* INSTALLED NEW VENT IN PARK BRAKE AIR CONTROLLER BLOCK	
DRAIN PLUG-ORDER AT252949	1.00	50.42	50.42	* INSTALL NEW AIR DRYER. BEEN REMOVED FROM SYSTEM COUNT FIND HOUSING TO REPLACE CARTRIDGE	
HUB FITTING PLUG-ORDER TT221449	4.00	26.30	105.20	* STARTED UNIT AND CHECK FLUIDS. TOPPED UP BRAKE OIL * REPAIR AIR LEAK FROM PARK BRAKE CONTROL. LOOSE BANJO FITTING	
BRAKE CALIPER -ORDER TT290421	1.00	9,251.54	9,251.54	* DIAG NO HYD FUNCTIONS. CHECKED FUSES AND CIRCUIT BEAKER. GOOD. CHECKED ELECTRICAL UNDER CAB GOING TO PUMP. DAMAGED SOLENOID TO CHECK. BRODY FOUND.	
SHIM -ORDER T254896	5.00	10.49	52.45	* CONNECTED LAPTOP TO GET DIAG CODES. NO ACTIVE CODES	
10W CAT OIL-STK HT4-10 Shop Supplies	33.00	4.13	136.29	* CHECK ELECTRICAL GOING TO HYD PUMP. NO ISSUES * NO OIL GETTING TO PUMP. CHECKED ALL WIRING CONNECTIONS THAT RELATES TO PUMP	
			100.00	* DRAINED HYD TANK AND REMOVE. CLEAN SUCTION SCREEN. CLEANED INSIDE TANK AS WELL * REFILLED HYD TANK. NO HYD OIL COMING FROM CASE DRAIN HOSE - MADE HOSE TO ATTACH TO CASE DRAIN AND FILLED HYD PUMP WITH OIL. GOT STEERING BACK * REPEAT PROCEDURE. BOX HOIST FUNCTION IS WORKING * INSTALL NEW PADS ON PARK BRAKE ASSEMBLY * CHECK AND MEASURE PUSH ROD STROKE 27MM * FOUND PROPER PROCEDURE TO PERFORM VALVE SET. FOUND T.D.C WENT TO CHECK IF IT WAS PROPER SPOT TO START VALVE SET. NO BAR ENGINE OVER 360 CHECK PUSH RODS AND VALVE FOR PLAY. GOOD * CYD #1,4,6 EXHAUST VALVES SET * BUILT TOOL TO TAKE APART THE ACCUMULATOR * INSTALL AND CHARGE ACCUMULATOR HOOK UP LINES. INSTALL GUARDS OVER SHRADER VALVES. INSTALL GUARD OVER ACCUMULATORS. BLEED BRAKES AND TOP UP HYD OIL * INSTALL MISSING TRANS GUARD. TOP UP TOCASE OIL. RUN UNIT AROUND YARD, FOUND VIBRATION IN DRIVE LINE. FOUND PARK BRAKE ROTOR WARPED AND GRABBING. MOVED INTO WASH BAY. * MOVE OUT OF WASH BAY. INSTRUCTED TO RE RUN UNIT. FOUND PARK BRAKE TO BE SET INCORRECTLY CAUSING FIRE UNDER UNIT AFTER MULTIPLE LAPS AROUND YARD. PUT FIRE OUT AND PROPERLY ADJUST PARK BRAKE. REMOVE GLAZING FROM ROTOR AND RE TEST. FOUND BRAKE WOULD NOT HOLD. ORDER NEW PADS * INSTALL PARK BRAKE ASSEMBLY. SET BRAKES AND TEST FUNCTIONS. GREEN FLAG. PARK IN LINE UP	

**WRENCHHEAD MECHANICAL**

3135 4 ST  
NISKU, ALBERTA. T9E-8L1  
Phone: 780-436-9570 Fax: 780- -

**INVOICE**

**35329**

Org. Est. # 052082

**INVOICE**

Ref #: 8362 HOURS

Date: 08/17/2021

**CHEMCO-OFF ROAD**  
3135-4 ST  
NISKU, ALBERTA T9E-8L1  
Office 780-436-9570

2006 JOHN DEERE - 400D 6X6 UNIT#ADT-5401 -  
Lic # : Odometer In : 0  
Unit # : ADT-5401  
VIN # : DW400DT605401  
Engine Hrs In : 8362.0 Engine Hours Out : 8362.0

Part Description / Number	Qty	Sale	Ext	Labor Description	Ext
---------------------------	-----	------	-----	-------------------	-----

Org. Estimate 8,744.79 Revisions 0.00 Current Estimate 8,744.79

Labor:	9,392.50
Parts:	20,100.12
SubTotal:	29,492.62
Tax:	1,474.63
Total:	30,967.25
Bal Due:	\$30,967.25

*STK 2949*

[ Payments - ]  
Vehicle Received: 5/27/2021

GST#865376503RT0001

Signature \_\_\_\_\_ Date \_\_\_\_\_

Customer Number : 3904

**WRENCHHEAD MECHANICAL**

3135 4 ST

NISKU, ALBERTA. T9E-8L1

Phone: 780-436-9570 Fax: 780- -

REPAIR ORDER #

**035329**

Org. Est. # 052082

**REPAIR ORDER - RO**

Scheduled : 05/19/2021 02:44 PM

Print Date : 5/19/2021

**CHEMCO-OFF ROAD**

3135-4 ST

NISKU, ALBERTA T9E-8L1

Office 780-436-9570

Cust ID : 3904

Last Service : No History

2006 JOHN DEERE - 400D 6X6 UNIT#ADT-5401 -

Lic # : - ALBERTA

Unit # : ADT-5401

VIN # : DW400DT605401

MFG Date : 5/19/2021

Current Odom : 0

Elapsed : 0

**Labor Requested / Part SubTotal**

**Extended**

(1) INSPECTION

65.00

Shop Supplies

Parts Subtotal 0.00

3.25

Parts: 0.00

Supplies: 3.25

Labor: 65.00

Tax: 3.41

Total: 71.66

Balance: 71.66

TEARDOWN ESTIMATE: I understand that my vehicle will be reassembled within \_\_\_ days of the date shown above if I choose not to authorize the service recommended. All Parts removed will be discarded unless instructed otherwise: Save all Parts \_\_\_. NOT RESPONSIBLE FOR LOSS OR DAMAGE TO MY VEHICLE OR ARTICLES LEFT IN VEHICLES IN CASE OF FIRE, THEFT OR ANY OTHER CAUSE. ALL VEHICLES LEFT MUST HAVE OWN INSURANCE. ANY VEHICLES LEFT OVER 30 DAYS WITHOUT CONSENT WILL BE PROPERTY OF WRENCHHEAD MECHANICAL.

Authorized By \_\_\_\_\_ Date \_\_\_\_\_ Time \_\_\_\_\_

Technician Work Sheet      Service Writer : GLAZIER, RUSSELL

Print Date: 5/19/2021

2006 JOHN DEERE - 400D 6X6 UNIT#ADT-540

Hat # :

Repair Order #

VIN # : DW400DT605401

Color :

035329

Engine :

Location :

Lic # :

Lic. State : ALBERTA

**CHEMCO-OFF ROAD**

Schedule : 5/19/21 2:45 P.M.

Office 780-436-9570

Promised Date : 5/19/21 5:00 P.M.

Inspection Date : 5/19/21

Status :

Last Service :

Unit # : ADT-5401

Current Odometer : 0

Trans :

Previous Mileage : 0

Brakes :

Elapsed Mileage : 0

Manufacture Date : 5/19/21

**Labor Description**

**Charged Hours**

Labor Description	Charged Hours
<input checked="" type="checkbox"/> (1) INSPECTION	1.00

Technician : <none>

OUT ODOMETER :

Total Hours Charged : 1.00

Hours out: 0.00

**Tech Notes**

*Hyd pump IS SLOW*

①

ADT-5401  
Unit #:

WO#035329.  
S/N:

Odometer:

Hours: 8362

Lab#	Repair Description	Date	Location	Tech Name	Hours
	- fire up unit Bring into Shop. Inspect unit make labour quote. move unit out of Shop. Build labour quote. Sweep floor. get quote Back. Instructed not to Repair many things. look up. Build Parts quote. move into back bay flip cap Drop fans	May 20	Shop	T Brady	6
	- lower cab p.a stump Pan up move to line up	May 20	Shop	T Brady	1
	- Bring up to Shop. Reglue Rear Window. Remove foggy head light glue Crack Clean lens & Install, Install Chemco Decals. Install fire Ext Bracket. we are currently out of Extinguishers. Repair R.H Step, Install Battery hold downs, troubleshoot Air Seat. unit did not originally come with air seat previous owners Ran wire from fuse Box and ground to frame. Plug wire Back into fuse Box, Air Seat works but the Repair job from previous owner is not very good. Work on trouble shooting lights ISSUE.	May 25	Shop	T Brady	7.5
1	Service all 3 Diff's Drain oil and fill and fill out oil Sample paper work	May 26 21	Shop	Brent Garcia	6. h
1	Remove and Replace air filters and clean Housing out. Serviced & took samples of all Final drives Monitor oil from Front left final drive and mid-right lots of <del>metal</del> fine metal in oil.	May 26/21	Shop	Derek Sinclair	4.5

Mechanic ID:

Mechanic Signature:

Parts

Qty.	Part #	Description	STK/ORD	Qty.	Part #	Description	STK/ORD
4		3/8" Fender Washers		2		large Chemco decals	
3	320271102	oil sample Bottle. ) Diff's	STK.	1		2lbs fire Ext Bracket	
122.45	75w90	gear oil	STK.	4		M8x 30mm Bolts	
1	TT221378	Inner air filter	ORD	8		M8 flat washers	
1	AH170798	air filter	ORD.	4		M8 lock washers	
6	320271102	oil sample bottle - Final Drives	ORD	4		M8 NUTS.	
1	320271102	oil sample bottle - Engine oil.		2		M10x 40MM B.S.HS	
35L		5w-40 engine oil	STK	2		M10 nuts	
1	TTDC021513	Engine oil filter.	ORD	2		M10 flat washers	

①

ADT-5401  
Unit #:

WO#035329.  
S/N:

Odometer:

Hours: 8362

Lab#	Repair Description	Date	Location	Tech Name	Hours
	- fire up unit Bring into Shop. Inspect unit make labour quote. move unit out of shop. Build labour quote. Sweep floor. get quote Back. Instructed not to Repair many things. look up. Build Parts quote. move into back by first cap Drop pans	May 20	Shop	Tracy	6
	- lower cab P.a Stump Pan up move to line up	May 20	Shop	Tracy	1
	- Bring up to Shop. Reglue Rear Window. Remove foggy head light glue Crack Cleanlens & Install, Install Chemco Decals. Install fire Ext Bracket. We are currently out of Extinguishers. Repair R.H Step, Install Battery hold downs, troubleshoot Air Seat unit did not originally come with air seat previous owners Ran wire from fire Box and ground to frame. Run wire back into fire Box, Air Seat works but the Repair job from previous owner is not very good. Work on trouble shooting lights Issue.	May 25	Shop	Tracy	7.5
1	Service all 3 Diff's Drain oil and fill and fill out oil Sample paper work	May 26 21	Shop	Brent Garcia	6. h
1	Remove and Replace air filters and clean Housing out. Serviced & took samples of all Final drives Monitor oil from Front left final drive and mid-right lots of <del>more</del> fine metal in oil.	May 24/21	Shop	Derek Sinclair	4.5

Parts

Mechanic ID:

Mechanic Signature:

Qty.	Part #	Description	STK/ORD	Qty.	Part #	Description	STK/ORD
4		3/8" Fender Washers		2		large Chemco decals	
3	320271102	oil sample bottle. ) Diff's	STK.	1		2lbs fire Ext Bracket	
45	75w90	gear oil	STK.	4		M8 3mm Belts	
1	TT221378	Innair air filter	ORD	8		M8 flat washers	
1	AH170798	air filter	ORD.	4		M8 lock washers	
1	320271102	oil sample bottle - Final Drives	ORD	4		M8 NUTS.	
1	320271102	oil sample bottle - Engine oil		2		M10 x 40 MM J.S.HS	
5L		5w-40 engine oil	STK	2		M10 nuts	
1	TTDC221513	Engine oil filter.	ORD	2		M10 flat washers	

Unit #: ADT-5401 S/N:

W.O# 035329

Odometer:

Hours: 8362

Lab#	Repair Description	Date	Location	Tech Name	Hours
	- Changed engine oil & filter	May 27/21	Shop	Derek Sinclair	10
	- Changed both fuel filters				
	- Drain brake oil <del>to</del> Tank and change leaking sight glass.				
	- Change Brake oil filter & tank breather.				
	- Replaced door knob in cab				
	- Replaced window latch - need another one.				
	- <del>Changed</del> changed breather on hydraulic tank.	May 28/21	Shop	DEREK S	10
	- Removed hydraulic tank filter - filter blown apart as well as housing - drained tank and took oil sample.				
	- Drained Transmission - got oil sample. <del>Replaced</del> Replaced both trans. filters & cut open - clean.				
	<del>Replaced transmission filter</del>				
	Installed new brake oil tank drain				
	Raised cab to find transmission fill				

Parts

Mechanic ID:

Mechanic Signature: \_\_\_\_\_

Qty	Part #	Description	STK/ORD	Qty.	Part #	Description	STK/ORD
✓	TTDC221512	Fuel filter	ORD				
✓	RE171321	Fuel Filter.	ORD				
✓	TT220736	Brake oil filter	ORD				
✓	AT253791	Breather	ORD				
✓	TT <del>221628</del> 221628	catch	ORD				
✓		oil sample bottle	STK				
✓	TT207967	CAP	ORD				
✓	AT211196	Drain valve	ORD				

3

Unit #: ADT-5401 S/N: W.O# 035329

Odometer:

Hours: 8362

Lab#	Repair Description	Date	Location	Tech Name	Hours
	Refill transmission	May 31/21	Shop	Derek Sinclair	10.
	Change cab filter				
	- Drained Transfer case -				
	damaged drain plug - ordered may 31/21				
	- Drained both front steer wheel brakes				
	Both mid axle wheels - brake oil				
	• Installed window catch - left window				
	- Started removing operator station panelling to replace				
	Am/Fm antenna & park brake control				
1	Remove Drive axl 2 fill plug and install New one that was ordered.	June 1, 21	Shop	Brent Garcia	10min.
1	Remove and Replace Hinges the DIS front Battery shut off	June 1, 21	Shop	Brent Garcia	20min.
	Box				
	- Filled hydraulic tank - 155 L - AW-30. Fill lid was <sup>over</sup> tight	June 2/21	Shop	Derek Sinclair	8.
	- Filled brake oil tank, 38L - AW-30				
	- Removed remaining guards & removed fan belt.				
	- Put drain plug in transfer case. - Filled with AW-30	June 4/21	Shop	Derek Sinclair	10
	- Installed 4 - brake drain plugs in brake oil housing. - Front wheels & mid wheels.				
	Installed fan belt & guards.				
	- Removed panels for park brake switch replacement.				
	- Remove stereo (not working) to get at Am/Fm antennas replaced.				

Parts Mechanic ID: Mechanic Signature:

Qty.	Part #	Description	STK/ORD	Qty.	Part #	Description	STK/ORD
33L		10w Drive train oil	STK.				
✓	TT226019	Cab filter.					
✓	15M7077	Fill Plug - transfer case	ORD				
✓	TT221449	Drain plugs - wheel brake oil drains	ORD				
✓	AT252949	Transfer case drain plug.	ORD				
✓	TT207660	Diff fill plug	ORD.				
✓	TT277487	Hinge for Battery Box	ORD.				
✓	159L	AW-30 Hydraulic oil	STK.				
✓	4.5L	AW-30					

Unit #: ADJ-5401 ~~SN~~: W.O # 035329

Odometer: ~~88~~

Hours: 8362

Lab#	Repair Description	Date	Location	Tech Name	Hours
	Started removing park brake air lines - not complete	June 4/21	Shop	Derek Sinclair	—
	- Removed Park brake controller & installed new one	June 7/21	Shop	Derek Sinclair	
	- Installed new vent in park brake air controller block	"	"		
	- Wire in & install 2 way radio				10
	- Wire in & install new AM/FM stereo				10
	- Finished mounting 2 way Radio and AM/FM stereo.	June 8/21		Derek Sinclair	
	- Installed gps, Re-install panels and secure loose wiring behind gauge cluster.				
	Install new air dryer - Been removed from system Couldnt find housing to replace cartridge				
	- Started unit & checked fluids - topped up brake oil tank.				
	- Repair air leak from park brake control	June 9/21		Derek Sinclair	10.
	- Loose banjo fitting.				
	- Trouble shoot no hydraulic functions - checked fuses & circuit breakers - good, checked electrical under cab going to pump - 1 damaged Solenoid to check. Problem found.				
	- Connected laptop to get diagnostic codes - no active codes.				
	- Trouble shoot hydraulic not functioning.	June 10/21			
	- Check electrical going to hydraulic pump. - no serious issues				

Parts Mechanic ID: Derek S Mechanic Signature: *DSS*

Qty.	Part #	Description	STK/ORD	Qty.	Part #	Description	STK/ORD
1	KD-X37MBS	Am/FM stereo - JVC	STK.	162		AW-29 Hydraulic oil.	STK
1		2-way radio	STK.				
1		Mic	STK.				
1		Antenna - UHF.	STK				
1	(XT6379A32)	GPS unit - serial # 202102379	STK				
	1007B08						
✓ 1	AT411898	Air dryer cartridge.	ORD.				
✓ 1	TT226224.	Park brake shoes	ORD				
582		AW-32 Hyd oil	STK.				







√ P = Pass F = Fail R = Repaired N/A = Not Applicable

UNIT #:		ODOMETER:				ENGINE HOURS:		DATE:			
		P	F	R	N/A			P	F	R	N/A
1	LOCKOUT IN PLACE	✓				21	Transmission Oil level / Internals Fluid levels		✓		
2	WHEEL CHOCKS IN PLACE	✓				22	Engine Coolant Fluid Level	✓			
3	Oil Samples	✓				22	Engine Oil Fluid Level		✓		
4	Overall Machine Loose Or Missing Nuts & Bolts, Loose Guards, Cleanliness		✓			23	Radiator Debris, Damage, Leaks	✓			
5	Lights Broken lamps, lenses, operation		✓			24	Overall Engine Compartment Trash Or Dirt Buildup, Leaks		✓		
6	Steering hydraulic system Leaks, worn hoses, damaged lines		✓			25	All Hoses Cracks, Wear Spots, Leaks	✓			
7	Underneath Machine Leaks, Damage, People Working		✓			26	All Belts Tightness, Wear, Cracks		✓		
8	Tires, rims, hub, stem caps Inflation, Leaks, Damage, Wear	✓				27	Overall Cab Interior Cleanliness		✓		
9	Brakes, Suspension Leaks, Damage, Wear		✓			28	Roll Over Protection System Damage	✓			
10	Grab Irons, Steps, Handholds Condition And Cleanliness		✓			29	Gauges, lights, switches Damage, operation		✓		
11	Battery Compartment Connections, Fluid level		✓			30	Seat Belt, Buckle & Mounting Damage, Wear, Adjustment	✓			
12	Air Filter Restriction Indicator	✓				31	Seat Adjustment, Brake Travel		✓		
13	Windshield Wipers & Washers Wear, Damage, Fluid Level		✓			32	Horn, backup alarm, lights Proper Function		✓		
14	Fire Extinguisher Charge, Damage		✓			33	Windows and Mirrors Condition, clean, adjust		✓		
15	Fuel tank, hydraulic tank Level, Leaks	✓				34	Drop Box Fluids / Internals	✓			
16	Body Damage, wear, distortion	✓				35	Preheat / Block Heater	✓			
17	Welds, castings; mounting bolts and pads Cracks; damaged bolts or pads	✓				36	SPILL KIT PROVIDED		✓		
18	All Axles Leaks, Damage, Wear	✓				37	Daily Inspection Booklet		✓		
19	Frame & Hoist Cylinders Cracks, Leaks, Damage, Wear	✓				38	FIRE EXT. CONDITION, DATE, TAG, LOCK, MOUNT		✓		
20	Suspension Cylinders Leaks, Measure cylinder height	✓				39	INSPECTION TAG DATE				
						40	FIRE EXTINGUISHER #:				

√ P = Pass F = Fail R = Repaired N/A = Not Applicable

		P	F	R	N/A		P	F	R	N/A
41	Grease Gun & Gease				✓	43	✓			
42	Heating Operation	✓				44		✓		

**TIRE PRESSURE** (If not recorded on prescribed Alberta Inspection Record) [ ] psi [ ] kPa

LF:		RF:		LR:		RR:	
-----	--	-----	--	-----	--	-----	--

**CHARGING SYSTEM TEST**

VOLTS:		AMPS:		RPM:			
--------	--	-------	--	------	--	--	--

**FUEL LEVEL:**

**TEST / DRIVE**

TEST [ ] or TEST DRIVE [ ]

Comments:

**CLEANING**

		Date	Time	Signature
Washed (Fine Cleaned)	<input type="checkbox"/>			
Disinfectant Mist (Clubroot)	<input type="checkbox"/>			

Technician (Print Name)

Technician Signature

**MAINTENANCE REQUIRED/REMARKS:**

**INSPECTION REPORT SIGN-OFF**

Technician (Print Name)	Technicians Signature	Supervisors Signature
-------------------------	-----------------------	-----------------------

# TITANGPS NON-CTS INSTALLATION REFERENCE SHEET

# chemco



**IMPORTANT**  
**MUST BE TESTED**  
CALL TO TEST GPS TRACKING DEVICE BEFORE CLOSING UP DAY!  
FAILURE TO FOLLOW THESE INSTRUCTIONS MAY DAMAGE EQUIPMENT AND VOID WARRANTY  
**CALL NOW**  
CERTIFIED TRACKING SOLUTIONS  
**1.780.391.3800**  
TOLL-FREE 1.855.287.4477 (CTS4GPS)

ESN:

**CERTIFIED** TRACKING SOLUTIONS   
PART #: XT6379A321007B08  
Serial #: 202102379  
IMEI #: 357649072235735

## COMPLETED BY INSTALLER

### VEHICLE INFORMATION - \*\*IMPORTANT\*\*

UNIT#/Name: ADT-5401  
Year: 2006 Make: John Deere Model: 400D Colour: Green  
VIN#: DW400DT605401 LIC Plate: \_\_\_\_\_  
Odometer: \_\_\_\_\_ Engine Hours: 8362

### Tracking Unit Location

Location 12V: \_\_\_\_\_ Ignition: \_\_\_\_\_ Ground: \_\_\_\_\_  
Wire Color 12V: \_\_\_\_\_ Ignition: \_\_\_\_\_ Ground: \_\_\_\_\_  
Antenna(s) Location: \_\_\_\_\_ Module Location: Behind gauge cluster.

## FINAL TESTING: (PLEASE CALL CTS at 780-391-3800 / 1-855-287-4477)

TESTED with CTS

INSTALLER NAME: Derek Sinclair

Date(DD/MM/YYYY): 08/06/2021 Time: 12:00pm SIGNATURE: 

**PLEASE NOTE:** CTS cannot be held liable for any damage to the asset or hardware when the install is performed by NON-CTS personnel. Installations performed by NON-CTS personnel are not subject to CTS warranty policies. Improper installation that causes any type of unit malfunction will void any warranty attached to the product. Charges will apply for the replacement of equipment and/or technical diagnosis of the issue.

**UPON COMPLETION OF INSTALLATION PLEASE FAX ATTN:**  
**Certified Tracking Solutions@ 780-391-3801 OR Scan and EMAIL TO:**  
**installs@ctstracking.com**

CTS Admin Use Only  Updated Work Order

<b>chemco</b>	<b>Parts Requisition</b>	<b>MTE-0130</b>
---------------	--------------------------	-----------------

UNIT #:	ADT 5401	UNIT TYPE/DESCRIPTION:	400D JD # DW400DT605401		
35329	ODOMETER:	ENGINE HOURS:	DATE:	May 20/21	

ITEM	QTY	PART#	DESCRIPTION	IN STOCK	ORDER
	1	TTDC221512	Fuel filter		
	1	TT222219	T-Case filter		
	1	TT220736	Brake filter		
	1	RE171321	Fuel filter		
	1	AT498275	Hyd filter		
	1	TT222389	Hyd filter		
	1	AT357236	Filter Kit Trans.		
	1	TTDC221513	Eng oil filter		
	1	TT210488	Disc Brake filter		
	1	TT140466	Filter o-Ring		
	1	AT257354	Fuel filter		
	1	TT226019	Case filter		
	1	TT221379	Outer Air filter		
	1	TT221378	Inner Air filter		
	1	JDS1500-16	Flywheel turning tool		

T Brody

Technician (Print Name)

Technicians Signature

<b>chemco</b>	<b>Parts Requisition</b>	<b>MTE-0130</b>
---------------	--------------------------	-----------------

UNIT #:	ADT5401	UNIT TYPE/DESCRIPTION:	400D JD		
ODOMETER:		ENGINE HOURS:		DATE:	May 20/21

ITEM	QTY	PART#	DESCRIPTION	IN STOCK	ORDER
	1	TT217421	gauge Brake oil		
	1	TT226932	Kubs		
	1	TTDC221514	Belt		
	1	TT266748	Antenna		
	1	TT206331	Wiper Blade		
	6	TTDC221650	valve cover gasket oil fill cover		
	5	TTDC221651	valve cover gasket		
	1	TT181860	Cab lifting Bear.		
	4	TT277487	hinge		
* STOP	1	TT221628	catch		
	30L		Sw-40 Eng oil.		
	34L		Trans oil JD Syntran		
	4.5L		T case oil JD Syntran		
	135L		Diff oil 4SL per gear oil.		
	37.8L		final drive oil 6.3L per.		
	45.3L		Brake oil JD Hyguard		
	178L		Hyd oil JD Hyguard.		

T. Sulp.

Technician (Print Name)

Technicians Signature