

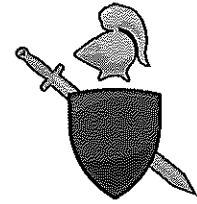

Warranty Solutions



The Extended Warranty Coverage by SMS Equipment Inc. ("SMS") is for the benefit of the customer named below (the "Owner"), will start when the Original Equipment Manufacturers ("OEM") Product Warranty ends.

The Owner agrees to the Warranty Solution level of coverage as per the initialed box below:

Coverage Description:	Sword	Shield	Armour
	<input type="checkbox"/>	<input type="checkbox"/>	<input checked="" type="checkbox"/>
Engine Including Electronic Controllers and Wiring Harness	●	●	●
Engine Emission System DPF, CCV, EGR, SCR, DEF System	●	●	●
Dampner, Power Take Off, Pump Drive Gear Box, Transfer Box	●	●	●
Torque Converter Including Modulating Slip Clutch	●	●	●
Transmission Including Pumps, Electronic Controllers, and Wiring Harness	●	●	●
Bevel Gear and Shaft, Planetary Steering Units, Steering Clutches	●	●	●
Final Drives, Differentials, Axle Assemblies	●	●	●
Tandem Drives, Drive Shaft, HST/HMT/HSS	●	●	●
Intelligent Machine Control (iMC)'s Wiring Harness and Sensors	●	●	●
Oils, Fluids and Filters if used in Repair	●	●	●
Piston Pump and Motors		●	●
Steering and Gear Pumps		●	●
Hydraulic Control Values and Cylinders		●	●
Hydrostatic Drive System		●	●
Hydraulic Vibration System Components		●	●
Accumulators (Brake, Steering, Hydraulic)		●	●
Swing Gear Box and Swing Bearing		●	●
Vibration Mechanism		●	●
Alternators and Starters			●
Radiators			●
Cab Heater and Air-Conditioning			●
Wiring Harnesses			●
All Electrical and Electronic Parts			●

The OEM Product Warranty commences on: 01-Jun-2023 (DD/MMM/YYYY)

The Extended Warranty ends on 31-May-2027 (DD/MMM/YYYY) or after 6000 hours of use as shown on the service meter attached to the Registered Machine, whichever occurs first.

Registered Machine Model: PC490LCI-11 Registered Machine Serial Number A45442

I have read and understand all of the terms and conditions for the Extended Warranty

Customer Name: AGGRESSIVE CONTRACTING LTD. Address: FORT ST. JOHN BC

Customer's Signature: [Signature] SMS Equipment Inc. [Signature]

(Warranty certificate not valid unless signed by SMS authorized signatory)

Date Signed: 12/06/2023 (DD/MMM/YYYY)

(Office Use Only) Unit Number MD0050942

General Terms and Conditions

1. Subject to these terms and conditions, SMS will repair, or at its discretion, replace any parts and components of the Registered Machine found to be defective in material or workmanship during the applicable warranty period as described on page 1.
2. For each warranty claim, there is no additional charge for up to 2 round trips by SMS personnel to site of Owner's operations to perform warranty service on the Registered Machine, including the following:
 - a. a total of 1000 kms round-trip maximum; and
 - b. a maximum of 12.5 hours travel time round-trip, during regular business hours.

Travel distance or time beyond the noted limits shall be charged to Owner at SMS' prevailing rates. If warranty field work is not practical, at SMS' sole discretion warranty services may be performed by SMS at its facilities during regular business hours and the cost to transport the Registered Machine or the defective parts or components to and from SMS' facility are to be paid by the Owner. The travel coverage outlined in this section does not apply to Takeuchi equipment.
3. The Registered Machine is the unit described on page 1, which has been purchased from SMS by the Owner.
4. This Extended Warranty does not cover the following: paint and finish, undercarriage wear parts, rubber tracks, all greaseable joints, operator's seat and all related seat parts (minus air ride system and heater kit), wiper blades, cables, oils, belts, filters, screens and elements, bulbs, brake pads and discs, fuses, batteries, tires, vibration bearings and seals, boom and stick attachments.
5. If SMS replaces a part or component of a Registered Machine under this warranty, the part or component removed becomes the property of SMS. The replacement part or component installed becomes the property of the Owner and is included in the balance of the term of this Extended Warranty. If SMS repairs a part or component, the repaired part or component included in the balance of the term of this Extended Warranty.
6. SMS shall have no obligation for the following:
 - a. defects or failures caused by misuse, misapplication, negligence, accident, acts of God, vandalism or deliberate act or failure to maintain (including periodical oil sampling as described below) or resulting from use other than in full compliance with the most current, applicable instructions issued by manufacturers or SMS;
 - b. alterations which are unauthorized by SMS and which in the sole judgment of SMS adversely affect the performance or safety of the Registered Machine or any of its parts or components;
 - c. defects or failures caused by the failure to furnish normal maintenance or operating services for the Registered Machine including, but not limited to, providing lubricants, fuel, tune-ups, inspections, oil sampling or adjustments;
 - d. defects or failures caused by any attachment or parts or components not manufactured by the original manufacturers or their subsidiaries (collectively "non-OEM Parts");
 - e. if Owner does not notify SMS of the claimed defect promptly after the defect occurs, if notice is not provided during the warranty period, or if the Registered Machine is not promptly made available to SMS for repair;
 - f. defects or failures resulting from the Owner's delay in making the Registered Machine available to SMS for repair or service after SMS has notified the Owner of a potential problem as identified by the manufacturer or by SMS itself;
 - g. if any repair or replacement of any part or component shall have been undertaken by anyone other than SMS;
 - h. for premiums charged for overtime labor requested by the Owner;
 - i. for defects or failures resulting from improper storage or improper transportation of the Registered Machine, part or component;
 - j. for excessive cleaning performed by SMS if required in preparation for warranty repairs;
 - k. for repairs or replacements required as a result of normal wear of products or parts, or required as a result of abuse;
 - l. if the Registered Machine is used outside Canada at any time;
 - m. attachments not manufactured by original equipment manufacturer, whether or not the attachment has a warranty from the attachment manufacturer.
7. ***In addition to factory recommended maintenance practices, the Owners are required to complete regularly scheduled oil samples (engines and other lubricated components at every drain interval or 500 hours, whichever comes first) for the Registered Machine. Owner will provide Oil reports to SMS promptly upon request.***
8. **WARNING RE: NON-OEM PARTS:** SMS strongly discourages the use of non-OEM Parts in Registered Machines. Non-OEM Parts may not be designed, manufactured or assembled to the manufacturer's design specifications, and use of non-OEM Parts may compromise the safe operation of the manufacturer's products and place the operator and others in danger if the non-OEM Part fails.
9. If Owner uses non-OEM Parts, Owner accepts full responsibility for the safe performance of the non-OEM Parts, and of the Registered Machine if non-OEM Parts are used. SMS is not responsible for the failure or performance of non-OEM Parts in the Registered Machine, including for any damage or personal injury resulting from or related to the Owner's use of non-OEM Parts.
10. This document, including all matters relating to the validity, construction, performance and enforcement thereof, shall be governed by the laws of British Columbia.
11. This Extended Warranty is assignable, but only with the prior written consent of SMS, which consent not to be unreasonably withheld.
12. The Parties, namely SMS and the Owner, confirm that they have requested and agreed that this document and any document, including notices, relating to this agreement be in the English language only. *Les parties, soit SMS et le propriétaire (Owner), confirment qu'ils ont exigé et convenu que ce document ainsi que tous les documents s'y rattachant, y compris tous avis, soient rédigés en anglais seulement.*
THE FOREGOING WARRANTY IS EXCLUSIVE AND IS IN PLACE OF ALL OTHER EXPRESS, STATUTORY OR IMPLIED WARRANTIES, REPRESENTATIONS AND CONDITIONS APPLICABLE TO THE REGISTERED MACHINE INCLUDING WITHOUT LIMITATION, ALL IMPLIED WARRANTIES, REPRESENTATIONS OR CONDITIONS OF MERCHANTABILITY AND FITNESS FOR ANY PARTICULAR PURPOSE. IN NO EVENT, WHETHER AS A RESULT OF BREACH OF CONTRACT OR WARRANTY OR ALLEGED NEGLIGENCE OR LIABILITY WITHOUT FAULT, SHALL SMS BE LIABLE FOR INDIRECT, SPECIAL, INCIDENTAL OR CONSEQUENTIAL DAMAGES, INCLUDING WITHOUT LIMITATION, LOSS OF PROFIT OR REVENUE, LOSS OF USE OF THE REGISTERED MACHINE OR ANY COMPONENTS THEREOF OR ANY ASSOCIATED EQUIPMENT, COST OF CAPITAL, COST OF SUBSTITUTED EQUIPMENT, FACILITIES OR SERVICES, DOWN TIME COSTS, LABOR COSTS, OR CLAIMS OF CUSTOMERS, PURCHASERS OR LESSEES FOR SUCH DAMAGES. THE ONLY REMEDIES AVAILABLE ARE THOSE UNDER THIS WARRANTY.



Customer's Initials



**Komatsu America Corp.
ACKNOWLEDGEMENT OF RECEIPT OF COMPANY WARRANTY
AND
AGREEMENT TO CUSTOMER CONSENT- MACHINE MONITORING SYSTEMS**

DATE June 12/23

DISTRIBUTOR SMS EQUIPMENT

CUSTOMER NAME: AGGRESSIVE CONTRACTING LTD.

ADDRESS FORT ST. JOHN BC
MD0050942

ADDRESS FORT ST. JOHN BC

SALES OR LEASE CONTRACT NUMBER

JUN 1, 2023

PC490LCI-11

DATE OF CONTRACT/DELIVERY

COMPLETE MACHINE MODEL
SAA8D125E-7

A45442

ENGINE MODEL

MACHINE SERIAL NO. (PRODUCT IDENTIFICATION NO.)
871527

ENGINE SERIAL NO.

STANDARD COVERAGE FOR THIS UNIT IS AS NOTED AND CHECKED BELOW:

- 1) 1 year, unlimited hours (max of 8700 SMR)
- 2) 3 years, 3000 hours max.
- 3) Others as defined- _____ mo/yrs/hrs

**BASIC WARRANTY PERIOD ONLY – ONE (1) YEAR, UNLIMITED HOURS
DOES NOT INCLUDE KOMATSU ADVANTAGE PROGRAM (EXTENDED COVERAGE)**

I, _____ have read and understand all of the terms and conditions of the attached Company Warranty Certificate which forms a part of my contract or lease. I understand that the expiration of the warranty as established on the said Warranty Certificate is established on the Machine's total use, and warranty conditions cannot be adjusted in any form for and in consideration of prior use.

CS
DISTRIBUTOR'S SIGNATURE

Markus B...
CUSTOMER'S SIGNATURE

TITLE _____

TITLE _____

COMPANY NAME AGGRESSIVE CONTRACTING LTD.

COMPANY ADDRESS FORT ST. JOHN BC



AGREEMENT TO CUSTOMER CONSENT - MACHINE MONITORING SYSTEMS
(Reference sheet 7 of 7)

I, _____ also acknowledge that I have read, understand and agree, and provide my consent, personally and on behalf of my Company, to the terms and conditions of the attached "Customer Consent - Machine Monitoring Systems." I certify that I am authorized to sign this agreement.

CUSTOMER NAME _____
CUSTOMER'S SIGNATURE Markus B...
NAME (Please Print) _____
TITLE _____
COMPANY NAME AGGRESSIVE CONTRACTING LTD.
COMPANY ADDRESS FORT ST. JOHN BC

WHITE (1 of 7) COMPANY SERVICE COPY
YELLOW (2 of 7) DISTRIBUTOR COPY
TAN (3 of 7) CUSTOMER COPY



KOMATSU PRODUCT WARRANTY

This product warranty certificate and the product warranty stated herein are applicable to all Komatsu products marketed under the brand name of Komatsu by Komatsu America Corp., herein after referred to as "Company".

1. GENERAL PROVISIONS

We warrant that all new whole machines and attachments ("Machines"), and new parts and assemblies for the Machines, including engines ("Parts") sold by the Company will be free from defects in materials and workmanship for the respective periods specified in paragraph 2 below, subject to the other terms and conditions herein.

2. BASIC WARRANTY

- A. The Basic Warranty Period for the Machine shall terminate upon the expiration of one (1) year after delivery of the Machine to the initial user regardless of the hours.
- B. The Basic Warranty Period for Parts shall be as follows:
 - i) For all replacement Parts furnished pursuant to this warranty, upon expiration of the remainder of the warranty period applicable to the Machine in which such Parts are installed.
 - ii) Other replacement Parts (Parts *not* furnished during the machine warranty period) may be covered under a separate warranty policy. Please consult your local Komatsu distributor.

3. COMPANY RESPONSIBILITIES

If a defect in material or workmanship is found during the Basic Warranty Period, the Company will, during normal working hours, at its option, repair or replace any part or component of the Machine or Part which fails to conform to the warranty during the Basic Warranty Period, provided our authorized Distributor is notified of such failure within the Basic Warranty Period.

4. CUSTOMER RESPONSIBILITIES

We recommend that you return the product to the Distributor from which it was purchased; however, you may also take it to the most convenient Company authorized Distributor contracted to service products of the type you have purchased. We do not assume the responsibility or cost of transporting the product to and/or from the servicing Distributor. You must also make the product available for repair during the Basic Warranty Period.

5. OTHER ENGINE MANUFACTURERS' WARRANTY

The above stated warranty does not apply to engines bearing other manufacturers' trademarks, whether or not such engines are installed in Machines or sold separately. The warranty responsibility on those engines rest with the respective engine manufacturers. Your Komatsu Distributor may be certified to perform warranty service on other manufacturers' engines.

6. LIMITATIONS

The Company shall not have any obligation under this warranty for:

- a. Any defects caused by misuse, misapplication, negligence, accident, improper storage, improper transportation, improper assembly or failure to maintain or use in accordance with the most current operating instructions including, but not limited to, loading the Machine in excess of the Gross Vehicle Weight as set out in the Company's Operation & Maintenance Manual;
- b. Unauthorized alterations;
- c. Defects or failures caused by any attachment or parts not manufactured or approved by the Company;
- d. Failure to conduct normal maintenance and operating services, including without limitation, providing lubricants, coolants, fuel, tune-ups, inspection or adjustments;
- e. Unreasonable delay (as established by Company) in making the applicable Machines or Parts available upon notification of a Factory Campaign ordered by the Company.

7. ITEMS NOT COVERED

The Company is not responsible for the following:

- a. Premiums charged for overtime labor requested by the purchaser;
- b. Charges related to transporting the product to and from the place at which warranty work is performed;
- c. Freight charges related to transporting repair parts to the place at which warranty work is performed;
- d. All used goods of any kind;
- e. Tires, tubes, wiper blades, belts, filters, cables, bulbs, condensers, spark plugs, glow plugs, fuses or carbon brushes, other consumable items, and normal wear of Machine or Parts;
- f. Attachments not manufactured or approved by the Company. (Trademarked attachments are warranted by their respective manufacturers.)

8. USE OF NON-OEM PARTS IN CRITICAL SYSTEMS

For safety reasons, the Company strongly recommends against the use of non-OEM replacement parts in critical systems of all Komatsu equipment. Critical systems include but are not limited to steering, braking and operator safety systems. Replacement parts manufactured and supplied by unauthorized sources may not be designed, manufactured or assembled to Komatsu's design specifications; accordingly, use of such parts may compromise the safe operation of Komatsu products and place the operator and others in danger should the part fail. Komatsu is also aware of repair companies that will rework or modify an OEM part for reuse in critical systems. Komatsu does not generally authorize such repairs or modifications for the same reasons as noted above. Use of non-OEM parts places full responsibility for the safe performance of the Komatsu product on the supplier and user. Komatsu will not in any case accept responsibility for the failure or performance of non-OEM parts in its products, including any damages or personal injury resulting from such use.

The foregoing warranty is exclusive and in lieu of all other express, statutory and implied warranties applicable to Machines, Engines, or Parts including without limitation, ALL IMPLIED WARRANTIES OF MERCHANTABILITY OR FITNESS FOR ANY PARTICULAR USE OR PURPOSE.

IN NO EVENT, WHETHER AS A RESULT OF BREACH OF CONTRACT OR WARRANTY, NEGLIGENCE, LIABILITY WITHOUT FAULT OR OTHER LEGAL THEORIES, SHALL THE COMPANY, OR ITS AFFILIATES, PARTNERS OR SUBSIDIARIES BE LIABLE FOR INDIRECT, SPECIAL, INCIDENTAL OR CONSEQUENTIAL DAMAGES, INCLUDING, WITHOUT LIMITATION, LOSS OF PROFIT OR REVENUES, LOSS OF USE OF THE MACHINE OR PARTS OR ANY ASSOCIATED EQUIPMENT, COST OF CAPITAL, COST OF SUBSTITUTE EQUIPMENT, FACILITIES OR SERVICES, DOWNTIME COSTS, LABOR COSTS, OR CLAIMS OF CUSTOMERS, PURCHASERS OR LESSEES FOR SUCH DAMAGES. THE REMEDIES HEREIN ARE THE EXCLUSIVE REMEDIES WITH RESPECT TO MACHINES AND PARTS, WHETHER UNDER THIS WARRANTY OR OTHERWISE.

EMISSION CONTROL WARRANTY

A. FEDERAL EMISSION CONTROL WARRANTY STATEMENT (APPLICABLE IN UNITED STATES and CANADA)

1. Products Warranted

Komatsu America Corp. ("Komatsu") produces and/or markets products under the brand name of Komatsu. This emissions warranty applies to new engines bearing the Komatsu name installed in these products and used in the United States and Canada in machines designed for industrial off-highway use.

2. Coverage

Komatsu warrants to the ultimate purchaser and each subsequent purchaser that the engine is designed, built and equipped so as to conform, at the time of sale by Komatsu, with all U.S. and Canadian Federal emission regulations applicable at the time of manufacture and that it is free from defects in workmanship or material which would cause it not to meet these regulations within five (5) years or 3,000 hours of operation, whichever occurs first, as measured from the date of delivery of the engine to the ultimate purchaser. If the machine in which the engine is installed is first placed in service in the state of California, a separate California Emission Warranty also applies.

3. Limitations

Failures, other than those resulting from defects in materials or workmanship, are not covered by this warranty. Komatsu is not responsible for failures or damage resulting from what Komatsu determines to be abuse or neglect, including, but not limited to: operation without adequate coolant or lubricants; over fueling; over speeding; lack of maintenance of lubricating, cooling or intake systems; improper storage, starting, warm-up, run-in or shutdown practices; unauthorized modifications of the engine. Komatsu is also not responsible for failures caused by incorrect fuel or by water, dirt or other contaminants in the fuel. Komatsu is not responsible for non-engine repairs, "downtime" expense, related damage, fines, all business costs or other losses resulting from a warrantable failure.

KOMATSU IS NOT RESPONSIBLE FOR INCIDENTAL OR CONSEQUENTIAL DAMAGES

B. CALIFORNIA EMISSION CONTROL WARRANTY STATEMENT

1. Products Warranted

This Emission Control System Warranty applies to heavy-duty off-road diesel engines certified with the California Air Resources Board, marketed by Komatsu America Corp. (Komatsu) in their Komatsu products and first placed in service in California for use in industrial off-highway applications.

2. Your Warranty Rights and Obligations

The California Air Resources Board and Komatsu are pleased to explain the emission control system warranty on your emissionized engine. In California, new heavy-duty off-road diesel engines must be designed, built and equipped to meet the State's stringent anti-smog standards. Komatsu must warrant the emission control system on your engine for the periods of time listed below provided there has been no abuse, neglect or improper maintenance of your engine. Your emission control system may include parts such as the fuel injection system and air induction system. Also included may be hoses, belts, connectors and other emission-related assemblies. Where a warrantable condition exists, Komatsu will repair your heavy-duty off-road diesel engine at no cost to you including diagnosis, parts and labor.

3. Manufacturer's Warranty Coverage

The heavy-duty off-road diesel engines are warranted for five (5) years or 3,000 hours of engine operation, whichever occurs first, from the date of delivery of the engine to the first user. If any emission-related part on your engine is defective, the part will be repaired or replaced by Komatsu.

4. Owner's Warranty Responsibilities

As a heavy-duty off-road diesel engine owner, you are responsible for the performance of the required maintenance listed in the Operation and Maintenance Manual. Komatsu recommends that you retain all receipts covering maintenance on your heavy-duty off-road diesel engine, but Komatsu cannot deny warranty solely for the lack of receipts or for your failure to ensure the performance of all scheduled maintenance.

You are responsible for presenting your heavy-duty off-road diesel engine to an authorized Komatsu Distributor as soon as a problem exists. The warranty repairs should be completed by the dealer as expeditiously as possible.

As the heavy-duty off-road diesel engine owner, you should also be aware that Komatsu may deny you warranty coverage if your heavy-duty off-road diesel engine or a part has failed due to abuse, neglect, improper maintenance or unapproved modifications. Your Engine may be required to operate on Diesel fuel or Ultra Low Sulfur Diesel fuel only. Consult the O&M Manual or the fuel decal at the machine's fuel filler port. Use of any other fuel may result in your engine no longer operating in compliance with California's emissions requirements. If you have any questions regarding your warranty rights and responsibilities, you should contact:

Komatsu America Corp.
 Manager, Warranty Administration
 P.O. Box 5049
 Suite 1-100
 One Continental Towers
 1701 W.Golf Rd.
 Rolling Meadows, IL 60008
 (847) 437-5800

Prior to the expiration of the applicable warranty, owner must give notice of any warranted emission control failure to an authorized Komatsu Distributor and deliver the engine to such facility for repair. Owner is responsible for incidental costs such as: communication expenses, meals, lodging incurred by owner or employees of owner as a result of a warrantable failure.

KOMATSU IS NOT RESPONSIBLE FOR INCIDENTAL OR CONSEQUENTIAL DAMAGES WHICH INCLUDE, BUT ARE NOT LIMITED TO, BUSINESS LOSSES AND COSTS, "DOWNTIME" EXPENSES, FINES, PENALTIES, THEFT, VANDALISM OR COLLISION DAMAGE.

5. Coverage: This emission control system warranty applies to the following emission control parts, if equipped:

Fuel Pump	Turbocharger	Injectors	Intake Manifold
AFC Spring	Compressor Wheel	Calibration	Charge Air Cooler
AFC Setting	Turbine Wheel	Needle	Aftercooler
Static Timing	Turbine Oil Seal	Nozzle	Positive Crankcase Ventilation
Delivery Valve	Wastegate Valve	Spring	
Fuel Lines			Other Emission Parts
Control Module	Exhaust Manifold		Hoses
	Exhaust Gas Recirculation Valve		Connectors
	Replacement Parts		

Komatsu recommends that any service parts used for maintenance, repair or replacement of emission control systems be new, genuine Komatsu or Komatsu approved rebuilt parts and assemblies, and that the engine be serviced by an authorized Distributor. The owner may elect to have maintenance, replacement or repair of the emission control parts performed by a facility other than an authorized Distributor and may elect to use parts other than new genuine Komatsu or Komatsu approved rebuilt parts and assemblies for such maintenance, replacement or repair; however, the cost of such service or parts will not be covered under this emission control system warranty.

6. Komatsu Responsibilities

Repairs and service will be performed by any authorized Distributor using new, genuine Komatsu or Komatsu approved rebuilt parts and assemblies. Komatsu will repair any of the emission control parts found by Komatsu to be defective without charge for parts or labor (including diagnosis which results in determination that there has been a failure of a warranted emission control part).

7. Warranty and Limitations

The manufacturer warrants to the ultimate purchaser, and each subsequent purchaser, that the engine is designed, built, and equipped so as to conform with all applicable regulations adopted by the Air Resources Board, and that it is free from defects in material and workmanship which cause the failure of a warranted part for the time periods stated herein. Any warranted part which is not scheduled for replacement as required maintenance, or which is scheduled only for regular inspection to the effect of "repair or replace as necessary" is warranted for the warranty period. Any warranted part which is scheduled for replacement as required maintenance is warranted for the period of time prior to the first scheduled replacement point for that part. The owner will not be charged for diagnostic labor which leads to the determination that a warranted part is defective, if the diagnostic work is performed at an authorized Distributor. The manufacturer is liable for damages to other engine components caused by the failure under warranty of any warranted part. Komatsu is not responsible for failures resulting from improper repair or the use of parts which are not genuine Komatsu or Komatsu approved parts. Komatsu is not responsible for failures resulting from owner or operator abuse or neglect, such as: operation without adequate coolant, fuel or lubricants; over fueling; over speeding; lack of maintenance of lubricating, cooling or air intake systems; improper storage, starting, warm-up, run-in or shutdown practices.

C. GENERAL EXCLUSIONS

1. The foregoing engine emission control warranties do not apply to engines in our products, which bear trademarks or names other than Komatsu (i.e. Cummins). The emission control warranty responsibility of such engines shall rest with the respective engine manufacturer. For information on such warranties, please refer to the operator's manual for the engine in question or contact the applicable dealer organization. In the case of Cummins trademarked engines, you may also contact your Komatsu distributor who may be certified by Cummins, under its Certified Distributor Program.
2. These warranties, together with the express commercial warranties, are the sole warranties of Komatsu. **THERE ARE NO OTHER WARRANTIES, EXPRESS OR IMPLIED, OR OF MERCHANTABILITY OR FITNESS FOR ANY PARTICULAR PURPOSE.**



CUSTOMER CONSENT - MACHINE MONITORING SYSTEMS

By signing the Agreement to Customer Consent - Machine Monitoring Systems (Agreement), Customer acknowledges and agrees to the following with respect to the machine(s) listed on the page on which it appears, as well as with respect to any other machines Customer owns, leases or otherwise uses that are equipped with Komatsu's KOMTRAX System (KOMTRAX), Vehicle Health and Monitoring System (VHMS) and/or Payload Meter (PLM). KOMTRAX, VHMS and PLM are collectively referred to as the "Systems". By signing the Agreement Customer also agrees to the Terms of Use of the Komtrax Service (Terms of Use), as set forth on the Komtrax website. The Terms of Use are available through <http://www.komtrax.us>, as may be updated from time to time by Komatsu to reflect any changes to KOMTRAX including the nature or quantity of data transmitted. By consenting to this Agreement, Customer is also consenting to any future updates to the Terms of Use.

Customer acknowledges that each machine is equipped with KOMTRAX. KOMTRAX is an equipment data tracking and monitoring system to manage information on utility, construction and mining machines. Such data may include details on machine location, usage and diagnostic information. In addition, KOMTRAX may be used to transmit messages and signals to the machine, including a signal that will disable the machine's ignition mechanisms.

Customer further acknowledges that each machine may be equipped with VHMS and/or PLM. VHMS is an equipment data tracking and monitoring system to manage information relating to machine usage, diagnostic and performance information, including, without limitation, items such as engine oil pressure, coolant temperature, fuel rate, engine speed, exhaust temperature and other machine and component information. PLM is a system which measures payload information during each haul truck haul cycle, including, without limitation, gross payload, maximum frame torque, and loading, dumping and driving times.

The information collected through the Systems is transmitted to Komatsu by means of automatic transmission, such as by satellite or other wireless means, and/or by means of manual download performed by Komatsu and/or its distributors and their respective personnel.

Customer consents to the collection, transmission and sharing of the information described above, and authorizes Komatsu America Corp. ("Komatsu"), its affiliates, subsidiaries and distributors to gather, process and use, without limitation, the information developed or collected by or in connection with the Systems. Customer acknowledges and agrees that all information developed or collected by or in connection with Systems shall be Komatsu's exclusive property, except for information provided by Customer, or on Customer's behalf, with respect to Customer's machines. Customer hereby grants to Komatsu a non-exclusive, worldwide, perpetual, irrevocable, royalty-free, sublicenseable right to exercise the copyright and other rights that Customer may have in any information collected by or in connection with the Systems for Komatsu, Komatsu affiliate, and Komatsu distributor business purposes, and for any other purposes, in any media now known or not currently known. This may include sharing of such information with select third parties and business partners.

Customer is responsible for performing any actions that are required by local law or regulation with respect to the collection and use of this information in the above manner, including, but not limited to, any required notification of employees or other parties of the collection and use of the information.

KOMATSU



COMPLIMENTARY KDPF EXCHANGE UNIT PROGRAM

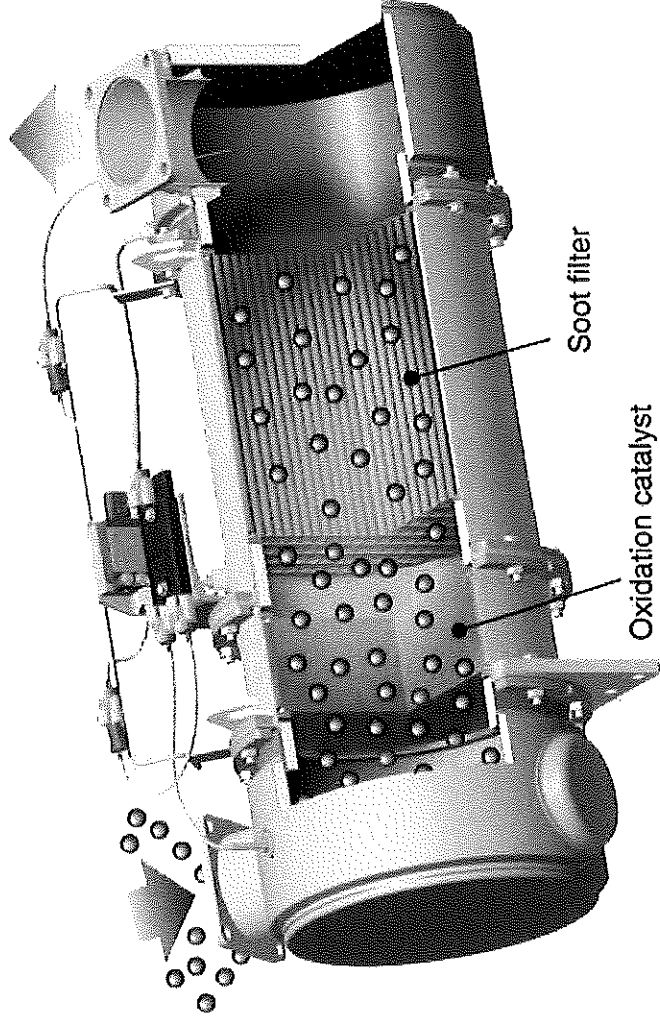

Complimentary KDPF Exchange Unit Program Customer Certificate For Tier 4 Interim and Tier 4 Final Construction Equipment

1) Program Details

For Customer's new Tier 4 Interim and Tier 4 Final Construction equipment (identified below) Komatsu America Corp. (KAC) will provide up to two complimentary Komatsu Diesel Particulate Filters (KDPF) over the course of the first five years from machine first-in-dirt date (FID), subject to the terms and conditions below. Qualification for complimentary KDPF exchange is based on the conditions below and proper machine maintenance as defined in section 3 of this document and in the machine's Operation and Maintenance Manual.

- a) Each complimentary exchange unit must be installed within 100 engine hours of the **recommended service intervals** as found in the machine's Operation and Maintenance Manual and explained below.

Recommended Service Interval
4500 hours and 9000 hours

- i) KAC must authorize, in writing, the exchange of a KDPF under this complimentary program, if an exchange unit is required outside the recommended service interval window shown above.
- ii) If a KDPF replacement takes place outside of the recommended service interval, the machine is then eligible for installation of a Complimentary KDPF Exchange Unit when the KDPF component reaches 4,500 (+/- 100) hours from the previous KDPF replacement. [For example: If a KDPF replacement take place at 3,500 machine hours under standard warranty, the Complimentary KDPF Exchange Unit replacement should take place at 8,000 (+/-) machine hours.
- b) The program is applicable to Tier 4 Interim and Tier 4 Final Construction Machines (Machines) wholesaled by KAC in the United States and Canada.
- i) Tier 4 Interim and Tier 4 Final construction machines eligible for this program are currently defined as follows:
- (1) Articulated trucks HM300 and HM400
 - (2) Dozers D61EX/PX, D65EX/PX/WX and D155AX
 - (3) Excavators PC210LC, PC228USLC, PC240LC, PC290LC, PC360LC, PC390LC and PC490LC
 - (4) Wheel Loaders WA270, WA320, WA380, WA470 and WA500

This list may be updated as eligible Tier 4 Interim and Tier 4 Final construction models are released.

2) Exclusions and Limitations

- a) The following expenses are excluded from this Program:
- i) Transporting the Machine to a Distributor facility for completion of installation or other covered repair and transporting the Machine back to the Machine's work location after completion of installation or other covered repair.
 - ii) Labor
 - iii) Additional services performed at the Customer's request outside the scope of the coverage time for such installation including, by way of example but not limitation, replacing parts and components outside such scope during the course of performing such installation on a covered Item.
 - iv) Travel time and mileage.
 - v) Consumables and other parts required to complete the installation, such as gaskets and clamps that may not be part of the complimentary exchange program.
- b) Failure of the KDPF resulting from the following are specifically excluded from this program:
- i) The use of oils other than Komatsu genuine or Komatsu recommended oil as specified in the Machine's Operation and Maintenance Manual.

- ii) Failure to maintain proper oil change intervals as described in the Machine's Operation and Maintenance Manual for the specific oil used.
- iii) Failure to follow proper fuel guidelines as outlined in the Machine's Operation and Maintenance Manual.
- iv) Fuel or oil contamination.
- v) Incomplete or faulty repair procedures on previous repairs completed by any person other than Distributor.
- vi) Fire, accidents, vandalism, theft, acts of terrorism or war, acts of nature or other causes beyond the direct control of Distributor.
- vii) Misuse, misapplication, negligence or other misconduct on the part of Customer or any other person.
- viii) Damage resulting from the failure of another component not covered under this program
- c) Exchanges outside of the recommended service interval where factory warranty or extended coverage is applicable

3) Customer Responsibilities:

- a) Removal and installation of KDPF must be performed by a Komatsu authorized Distributor
- b) Perform Komatsu Oil and Wear Analysis (KOWA) per the prescribed oil sampling intervals as found in the Machine's Operation and Maintenance Manual.
- c) Operate, maintain, store, repair and otherwise use the Machine per the guidelines specified in the Operation and Maintenance Manual, Machine specific Payload Policy and all other notices or letters from Distributor or Komatsu concerning such topics.
- d) Maintain KOMTRAX and other machine information systems in good operating condition and repair at all times and allow KAC and the Komatsu Distributor access to the machine information system data.

4) Distributor Responsibilities:

- a) Distributor will exercise commercially reasonable efforts to respond promptly to any Customer requests and questions related to this Program.
- b) Distributor will carry out covered repairs during normal Distributor working hours.

5) Komatsu Responsibilities

- a) Provide the authorized Komatsu distributor the new or remanufactured (like new) KDPF exchange unit, through the normal parts ordering channel.

6) Transferability:

This Program is specific to the Customer listed below and Machine listed in Section 1(b) and listed below by serial number. Customer may not assign its right under this Program without the prior written consent of KAC (such consent not to be unreasonably withheld).

7) Limitation of Liability:

The rights and obligations of the parties under this Program is subject to the exclusions, disclaimers, limitations of liability and other terms and conditions specified in the standard manufacturer warranty certificate issued by Komatsu America Corp. on the machine in question.

I hereby certify that I have read the above terms and conditions of this Program Certificate.

KOMATSU DISTRIBUTOR:

By: SMS EQUIPMENT INC.

Name: Corissa Fenster

Title: PSSR

CUSTOMER:

By: AGGRESSIVE CONTRACTING LTD.

Name: Marc R.

Title: Superintendent

Machine Serial No.: A45442



KOMATSU Service Report

HYDRAULIC EXCAVATORS

Report No.

Inspector Name

Machine Model	Type	Serial No.	Engine Model	Serial No.	Machine Status	Machine In stock	Pre-Delivery	Delivery	1st Service	2nd Service	3rd Service	Add. Service
PC490LCI	11	A45442	SAA6D125E-7	871527	New	W30	W41P	W41N	W411	W412	W413	W41X
					Used		W41P	W41U	W4U1	---	---	W4UX
Date of Service	SMR	Customer Name		Distributor Code	Distributor Name							
		AGGRESSIVE CONTRACTING LTD.			SMS EQUIPMENT							
Country Code	Location											
CA	FORT ST. JOHN BC											
Attachment(s)												
Make	Model	Serial No.	Make	Model	Serial No.	Applications						

NOTE: Below are the items related to operation, maintenance and lubrication of this machine to be performed at Pre-Delivery, Delivery, Periodic and Add Service. The Operation & Maintenance Manual details all items to maximize machine availability. Some items may not apply to certain models.

X Item to be Serviced | G: Good Condition | B: Bad Condition | C: Correction Made

S : Service
D : Discuss (Guide to customer)

HYDRAULIC EXCAVATORS

Item	Pre-delivery	Revisit				Check
		Delivery	S	D	S	
1 Visual Check (Damage, loose bolts, rust, leakage, wiring)	X	X	X	X	X	X
2 Lubrication or Service Chart Installed	X	X	X	X	X	X
3 MARKS & PLATES INSTALLED (safety, operation, lubricating, etc.)	X	X	X	X	X	X
4 Attachment(s) Installed	X	X	X	X	X	X
5 Fluid Compartment Check						
Fuel Tank	X	X	X	X	X	X
Battery Electrolyte	X	X	X	X	X	X
Anti-freeze Protection & Radiator Coolant Level	X	X	X	X	X	X
Engine Oil Pan(s)	X	X	X	X	X	X
Transmission Case - Wheel Model Only	X	X	X	X	X	X
Differential Housing - Wheel Model Only	X	X	X	X	X	X
Final Drive Case	X	X	X	X	X	X
Track Rollers & Idlers	X	X	X	X	X	X
Hydraulic Tank	X	X	X	X	X	X
Swing Machinery	X	X	X	X	X	X
PTO case	X	X	X	X	X	X
Brake Oil tank - Wheel Model Only	X	X	X	X	X	X
6 Service						
Lubricate per Lubrication or Service Chart	X	X	X	X	X	X
Fuel Tank & Filter Sediment	X	X	X	X	X	X
Drive Belt Tension(s)- Fan, Alternator, etc.	X	X	X	X	X	X
Air Cleaner Element(s) & Connections	X	X	X	X	X	X
Radiator Core & Cooling System Connections	X	X	X	X	X	X
Engine Oil Filter(s), Fuel Filter(s) & Breather	X	X	X	X	X	X
Hydraulic Oil Filter Element(s) & Tank Breather	X	X	X	X	X	X
Inspect Entire Machine for Broken Welds, Cracks, and Distortions	X	X	X	X	X	X
Track Tensions	X	X	X	X	X	X
Wear of Undercarriage, Bucket Cutting Edges and/or Teeth	X	X	X	X	X	X
Tire Air Pressure - Wheel Model Only	X	X	X	X	X	X
Tire Wear - Wheel Model Only	X	X	X	X	X	X
Undercarriage Torques - Shoes, Links, Sprockets, etc.	X	X	X	X	X	X
KOMTRAX/VHMS Function - if applicable	X	X	X	X	X	X

Item	Pre-delivery	Revisit				Check
		Delivery	S	D	S	
7 Operation						
Monitor Panel (Instrument Panel Gauges, Warning Lights, Indicators) and Switches	X	X	X	X	X	X
Unusual Machine Noise	X	X	X	X	X	X
Warning Horn, Lights & Window Wipers	X	X	X	X	X	X
Motion Alarm	X	X	X	X	X	X
Throttle Control	X	X	X	X	X	X
Travel Movement	X	X	X	X	X	X
Swing Lock & Brake	X	X	X	X	X	X
Control Lever Stroke, Play & Operating Force	X	X	X	X	X	X
Boom, Arm & Bucket	X	X	X	X	X	X
Attachment(s)	X	X	X	X	X	X
Brake Pedal & Brake - Wheel Model Only	X	X	X	X	X	X
Parking Brake - Wheel Model Only	X	X	X	X	X	X
Outriggers - Wheel Model Only	X	X	X	X	X	X
Air line leakage	X	X	X	X	X	X
Engine Low Idle RPM Record	X	X	X	X	X	X
Engine High Idle RPM Record	X	X	X	X	X	X
Hydraulic relief pressure Record	X	X	X	X	X	X
Procedure for using multi-monitor and KOMTRAX	X	X	X	X	X	X
8 Guidance						
Safe Operation & Maintenance	X	X	X	X	X	X
Procedure for Starting & Stopping Engine	X	X	X	X	X	X
50 & 100 Hour Maintenance Service	X	X	X	X	X	X
250 Hour Maintenance Service	X	X	X	X	X	X
500 Hour Maintenance Service	X	X	X	X	X	X
1000 Hour Maintenance Service	X	X	X	X	X	X
2000, 4000, 5000, 8000 Hour Maintenance Service	X	X	X	X	X	X
Warranty & Service Rules	X	X	X	X	X	X
Service Tools & Publications	X	X	X	X	X	X
Spare Parts Ordering Procedure	X	X	X	X	X	X
9 Other						
Operation & Maintenance Manual Review	X	X	X	X	X	X
Parts Book Review	X	X	X	X	X	X
Safety Manual Review	X	X	X	X	X	X
ROPS Installed condition - if applicable Serial No:	X	X	X	X	X	X

Machine Maintenance Programs

Offer and explain the programs listed below. List details in "Specify" if the machine is already enrolled in a particular program.

Advantage Extended Coverage Specify _____ PM PRO Specify _____
 Repair and Maintenance Contract Specify _____ KOWA Specify _____

This machine has been serviced and is in satisfactory condition. Adequate information has been given on its operation, care and maintenance. The Operation & Maintenance Manual has been received. All literature and explanations that pertain to safe machine operation have been received and understood.

Customer Comments: _____

Inspector Comments: _____

Customer Signature: Marco [Signature]

Inspector Signature: [Signature]

Complimentary Maintenance Program Details

1. Coverage:

- a) For Customer's new Tier 4 Interim & Tier 4 Final Construction equipment with a horsepower rating between 75HP and 475HP, Komatsu Distributor will provide for the Customer's eligible Machine the parts, labor, fluids, oil sampling and other covered services consistent with the recommended maintenance schedule outlined in the machine's Operator and Maintenance Manual. This program covers the filters and fluids called for in the recommended initial 250 (i250), 500, 1000, 1500, and 2000 SMR maintenance intervals (i250 intervals are not covered on hydraulic excavators and dozers smaller than D85). A listing of the tasks currently covered can be provided by the Distributor to the machine owner.
- b) For Customer's new Tier 4 Interim & Tier 4 Final Construction equipment with a horsepower rating between 50HP and 74HP, Komatsu Distributor will provide for the Customer's eligible Machine the parts, labor, fluids, oil sampling and other covered services for the recommended 500, 1000, 1500, & 2000 SMR maintenance schedule outlined in the machine's Operation and Maintenance Manual for the following items:
 - i) Engine oil & filter
 - ii) Fuel pre-filter
 - iii) Fuel main filter
- c) Customer's new Tier 4 Interim & Tier 4 Final Construction equipment with a horsepower rating 49HP and lower is not eligible for a complimentary maintenance program.
- d) For Customer's new Tier 4 Interim & Tier 4 Final Construction equipment with a horsepower rating from 476HP and higher, Komatsu Distributor will provide for the Customer's eligible Machine the parts, labor, fluids, oil sampling and other covered services for the recommended 500, 1000, 1500, & 2000 SMR maintenance schedule outlined in the machine's Operation and Maintenance Manual for the following items:
 - i) Engine oil & filter
 - ii) Fuel pre-filter
 - iii) Fuel main filter
 - iv) Diesel exhaust fluid (DEF) pump filter
 - v) Diesel exhaust fluid (DEF) tank breather
 - vi) KCCV filterA listing of the tasks currently covered can be provided by the Distributor to the machine owner.
- e) The Machine will be eligible for this coverage starting with its "first-in-dirt date" (FID) and zero SMR hours (this date being reflected on the program certificate as the "Begin Date") and expiring the earlier of the date on which the Machine has accumulated 2000 SMR hours or the date that is three years from the FID. The phrase "SMR hours" represent the engine run time for the Machine and are measured using the hour meter or monitor panel installed in the Machine's operator cab.

2. Exclusions and Limitations:

The obligations of the authorized Komatsu Distributor under this Agreement will not include:

- a. Overtime Labor requested by the customer beyond the Komatsu Distributor standard business hours.
- b. Machine transportation costs.
- c. Parts handling fees.
- d. Additional services performed at the Customer's request outside the scope of this agreement.
- e. Costs incurred due to Site Access delays
- f. Costs incurred due to Site Orientation
- g. Costs incurred due to Customer site Work Alone policies.

3. Customer Responsibilities:

- a. Operate, maintain, store, repair and otherwise use the Machine per the guidelines specified in the O&M Manual, Machine specific Payload Policy and all other notices or letters from Distributor or Komatsu concerning such topics.
- b. Perform the maintenance items noted as "Initial 250 hours" and "When Required" in the machine's Operation and Maintenance Manual (example: Replace Engine Air Cleaner Elements).
- c. To be eligible for the Komatsu CARE program, the KOMTRAX and other machine information systems must be functional and in good operating condition and repair at all times and allow Komatsu America Corp. and the Komatsu Distributor access to the machine information system data.
- d. Contact your local Komatsu Distributor to schedule any maintenance covered by this program. To be eligible for the Komatsu CARE program, all maintenance work must be completed within 100 hours of the stated interval (for example, between 400 and 600 smr for the 500 hr service). While your Komatsu distributor will make every reasonable effort to accommodate your schedule in arranging the maintenance visit, it is ultimately the responsibility of the customer to ensure timely completion of the maintenance work. Your Komatsu Distributor Servicing Branch must be contacted within 96 hours or 7 days prior to the scheduled service interval.
- e. Schedule the 2,000 hour interval's work to be completed between 1,900 and 2,000 machine SMR.

4. Billing and Payments

- a. The Komatsu CARE program will contribute up to a \$ 300 credit towards travel expenses (Time & KM's) per service.
If the travel expense is greater than \$ 300 the balance remaining will be the customer's responsibility.

5. Transferability:

- a. This Agreement is specific to the Machine listed in Section 1 and Customer listed below.
Customer may not assign its right under this Agreement without the prior written consent of Komatsu America Corp. (such consent not to be unreasonably withheld).

6. Limitation of Liability:

- a. The rights and obligations of the parties under this Agreement is subject to the exclusions, disclaimers, limitations of liability and other terms and conditions specified in the standard manufacturer warranty certificate issued by Komatsu America Corp. on the machine in question. By way of example and not limitation, the Komatsu Distributor will not be obligated under this Agreement to repair damage caused by acts of nature, operator negligence or misuse, vandalism, etc.

I hereby certify that I have read the above terms and conditions of the program certificate.

KOMATSU DISTRIBUTOR:

CUSTOMER:

By: SMS EQUIPMENT INC.

By: AGGRESSIVE CONTRACTING LTD.

Name: Corissa Feenstra

Name: Marco R.

Title: PSSR

Title: Superintendent

Machine Model and Serial No: PC490LCI-11 A45442



KOMATSU

Undercarriage Program Certificate

Komatsu America Corp. is pleased to provide you with additional coverage for the undercarriage on your Komatsu machine. The Komatsu Undercarriage Program will provide coverage against leakage (a/k/a dry) and breakage (a/k/a fracture) due to defects in material or workmanship for the term of (i) 60 months or 6000 hours for Plus System Undercarriage (measured from first fit or replacement purchased) or (ii) 48 months or 5000 hours Conventional Undercarriage (measured from first fit or replacement purchased), whichever occurs first, starting with the machine's date of delivery (as recorded in Komatsu's machine delivery database).

Components Covered

- Link Assemblies, excluding shoes and pads
- Track and Carrier Rollers
- Front Idlers
- Sprocket Teeth

Repairs Covered

- Breakage; (fracture) Part must not have reached or exceeded 100% worn
- Leakage (dry) of rollers and idlers; Tread surface must not have reached or exceeded 100% worn
- Leakage (dry) of track pin and bushing seal prior to a pin and bushing turn; Bushing wear and link height must not have reached or exceeded 100% worn
- Repair costs for the covered components will be on a prorated basis if the failure occurs outside the Product Warranty Term.
- Failures related to running U/C parts beyond 100% wear life, operator abuse, or neglecting to maintain machine in accordance with the Komatsu Operation and Maintenance manual will not be covered under this program. Additionally, failures caused by link packing in landfill applications are also not eligible under this program.
- Leakage (dry) of track pin and bushing seal after turn is not covered under this program.

This coverage will reimburse your servicing distributor for the cost of parts and labor for the repair. This coverage does not reimburse for travel time, mileage, transportation costs, or other expenses for the mechanic, machine, or components involved in the repair.

Requirements

You must follow all maintenance requirements stated in the Operation and Maintenance manual for the respective machine carrying this coverage. This will include maintaining proper track tension, replacing or repairing all undercarriage guards, and reporting any leaks or unusual wear patterns to your Komatsu distributor promptly. Machine configuration must be within the Komatsu published standards and operated within its design limitations. Any abnormalities must be promptly reported to your servicing Komatsu distributor. Your selling Komatsu distributor will advise you of any additional requirements that may exist.

To ensure the longest possible life for your Komatsu Crawler Dozer, proper track shoe selection is essential and should be determined by taking into account the application and underfoot conditions. Breakage (fracture) or leakage (dry) caused by an inappropriate shoe selection is not covered under the terms of this program.

Any repairs or replacements made under the Undercarriage Program will continue to be covered for the remaining term of the machine's Undercarriage agreement.

Claim Procedure

If a problem occurs with a component covered under this program, transport it to your servicing Komatsu distributor. If the component needs service, Komatsu will repair or replace the part(s) at our expense, as outlined in this document.

Machine and customer information

Customer Name AGGRESSIVE CONTRACTING LTD. Machine Model, type and subtype PC490LCI-11
 Machine serial Number A45442 Distributor name & 4+2 SMS EQUIPMENT

KOMATSU®

**COMPLIMENTARY
SCR SYSTEM MAINTENANCE PROGRAM**

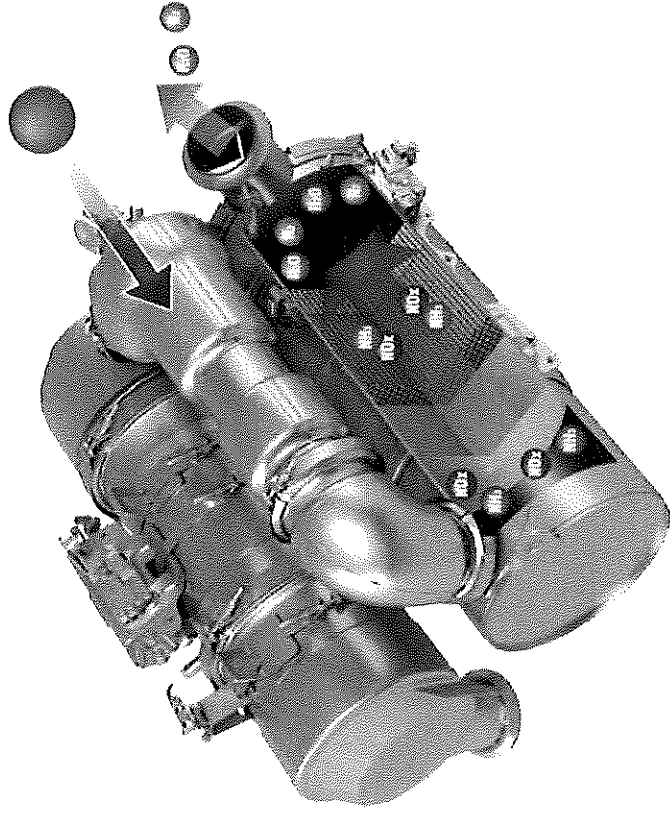

Complimentary Selective Catalytic Reduction (SCR) System Maintenance Program Customer Certificate For Tier 4 Final Construction Equipment

1) Program Details

For Customer's new Tier 4 Final Construction equipment (identified below) Komatsu America Corp. (KAC) will provide up to two complimentary Selective Catalytic Reduction (SCR) System Maintenance services to include AdBlue®/DEF tank flushing & AdBlue®/DEF tank strainer cleaning over the course of the first five years from machine first-in-dirt date (FID), subject to the terms & conditions below. Qualification for the complimentary SCR System Maintenance is based on the conditions below and proper machine maintenance as defined in section 3 of this document and in the machine's Operation and Maintenance Manual.

- a) Each complimentary SCR System Maintenance must be performed within 100 engine hours of the **recommended service intervals** as found in the machine's Operation and Maintenance Manual and explained below.

Recommended Service Interval
4500 hours and 9000 hours

- i) KAC must authorize, in writing, the servicing of the SCR System Maintenance under this complimentary program if the maintenance is required outside the recommended service interval window shown above.
- b) The program is applicable to Tier 4 Final Construction Machines (Machines) wholesaled by KAC in the United States and Canada.
 - i) Tier 4 Final construction machines eligible for this program are currently defined as follows:
 - (1) Articulated trucks up to and including HM400-5
 - (2) Dozers up to and including D155AX-8
 - (3) Excavators up to and including PC490LC-11
 - (4) Motorgraders GD655-6
 - (5) Wheel loaders up to and including WA470-8

This list may be updated as eligible Tier 4 Final construction models are released.

2) Exclusions and Limitations

- a) The following expenses are excluded from this Program:
 - i) Transporting the Machine to a Distributor facility for completion of installation or other covered repair and transporting the Machine back to the Machine's work location after completion of installation or other covered repair.
 - ii) Additional services performed at the Customer's request outside the scope of the coverage time for such installation including, by way of example but not limitation, replacing parts and components outside such scope during the course of performing such installation on a covered Item.
 - iii) Travel time and mileage.
 - iv) Consumables and other parts required to complete the maintenance.
- b) Failure of the SCR system resulting from the following are specifically excluded from this program:
 - i) The use of AdBlue®/DEF other than Komatsu genuine or API Certified AdBlue®/DEF as specified in the Machine's Operation and Maintenance Manual.
 - ii) Failure to follow proper AdBlue®/DEF guidelines as outlined in the Machine's Operation and Maintenance Manual.
 - iii) AdBlue®/DEF contamination.

- iv) Incomplete or faulty repair procedures on previous repairs completed by any person other than Distributor.
- v) Fire, accidents, vandalism, theft, acts of terrorism or war, acts of nature or other causes beyond the direct control of Distributor.
- vi) Misuse, misapplication, negligence or other misconduct on the part of Customer or any other person.
- vii) Damage resulting from the failure of another component not covered under this program

3) Customer Responsibilities:

- a) AdBlue®/DEF tank flushing & AdBlue®/DEF tank strainer cleaning must be performed by a Komatsu authorized Distributor
- b) Operate, maintain, store, repair and otherwise use the Machine per the guidelines specified in the Operation and Maintenance Manual, Machine specific Payload Policy and all other notices or letters from Distributor or Komatsu concerning such topics.
- c) Maintain KOMTRAX and other machine information systems in good operating condition and repair at all times and allow KAC and the Komatsu Distributor access to the machine information system data.
- d) Maintain the cleanliness & quality of AdBlue®/DEF fluid used in the Machine & stored at the Customer location(s).

4) Distributor Responsibilities:

- a) Distributor will exercise commercially reasonable efforts to respond promptly to any Customer requests and questions related to this Program.
- b) Distributor will carry out covered repairs during normal Distributor working hours.

5) Komatsu Responsibilities

- a) Provide the authorized Komatsu distributor the required AdBlue®/DEF, through the normal parts ordering channel.

6) Transferability:

This Program is specific to the Customer listed below and Machine listed in Section 1(b) and listed below by serial number. Customer may not assign its right under this Program without the prior written consent of KAC (such consent not to be unreasonably withheld).

7) Limitation of Liability:

The rights and obligations of the parties under this Program is subject to the exclusions, disclaimers, limitations of liability and other terms and conditions specified in the standard manufacturer warranty certificate issued by Komatsu America Corp. on the machine in question.

I hereby certify that I have read the above terms and conditions of this Program Certificate.

KOMATSU DISTRIBUTOR:

By: SMS EQUIPMENT INC.

Name: Corissa Feenstra

Title: PSSR

CUSTOMER:

By: AGGRESSIVE CONTRACTING LTD.

Name: Marco Bini

Title: Superintendent

Machine Serial No.: A45442