

18,877 LB (8,562 KG) 18,877 LB (8,562 KG)
LOAD ON EACH TIRE (4)

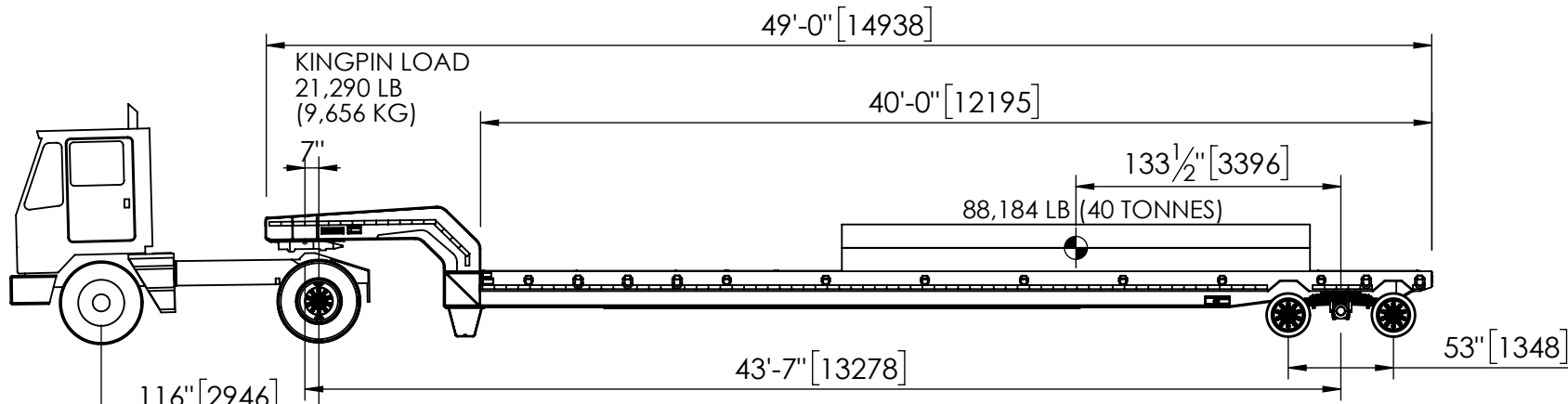

9,260 LB TARE 10,051 LB
1,285 LB PAYLOAD 20,005 LB
10,545 LB TOTAL 30,056 LB
(5,500 KG) (13,633 KG)

EMPTY TRAILER WEIGHT: 12,908 LB (5,855 KG)
TRUCK WEIGHT USED: 15,000 LB (6,803 KG)
TOTAL LOADED WEIGHT: 116,108 LB (52,666 KG)

TARE 8,597 LB
PAYLOAD 66,910 LB
TOTAL 75,507 LB
(34,249 KG)



FRACTIONS CHART					
1/32	.03125	9/32	.28125	17/32	.53125
1/16	.0625	5/16	.3125	9/16	.5625
3/32	.09375	11/32	.34375	19/32	.59375
1/8	.125	3/8	.375	5/8	.625
5/32	.15625	13/32	.40625	21/32	.65625
3/16	.1875	7/16	.4375	11/16	.6875
7/32	.21875	15/32	.46875	23/32	.71875
1/4	.25	1/2	.5	3/4	.75

UNLESS OTHERWISE SPECIFIED
DIMENSIONS ARE IN INCHES
TOLERANCES ARE:
FRACTIONS ANGLES
+/- 1/16" +/- 1°
.XX" .XXX"
+/- 0.03" +/- 0.005"

DIMENSIONS TO SHARP POINTS

REV.	CHANGES OR ADDITIONS	DATE	REV. BY
SHEET NAME Sheet1		TITLE 40FT BRIDGE MAFI WITH PANEL LOAD	
CURRENT CUSTOMER		STOCK NUMBER	VENDOR NUMBER
WO#		DRAWN BY HM	DRAWN DATE 8/22/2023
SCALE 1:90		MODELLER HM	DRAWING NUMBER AA-62427
			WEIGHT - LB. 0.0
			NUMBER OF SHEETS 1

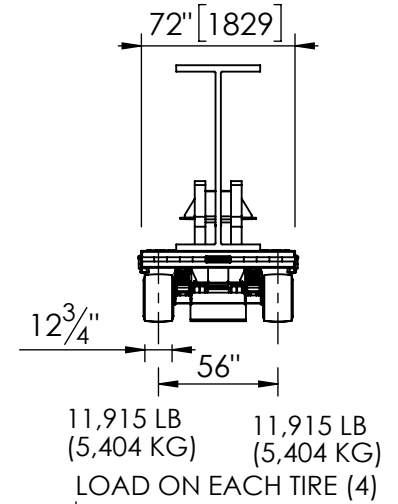
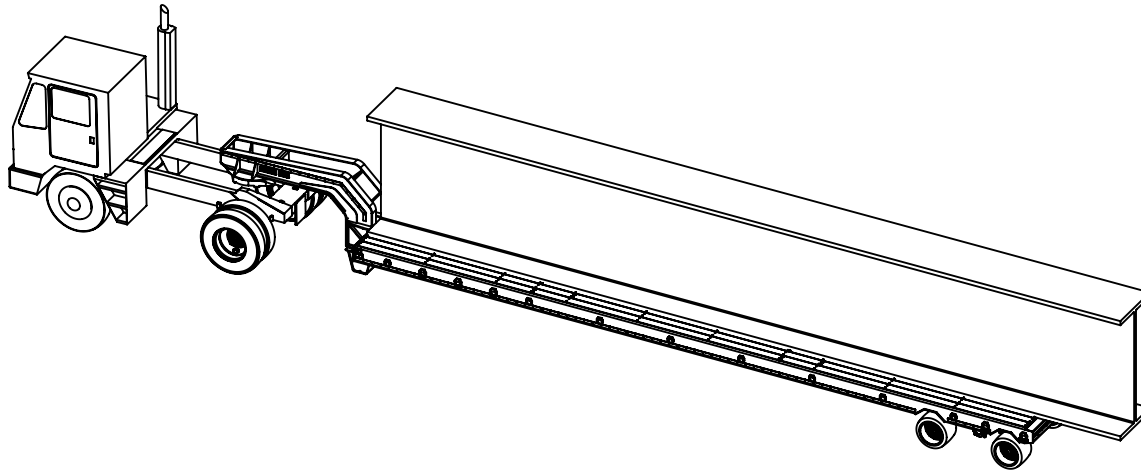

44'-4 1/4" [13520]

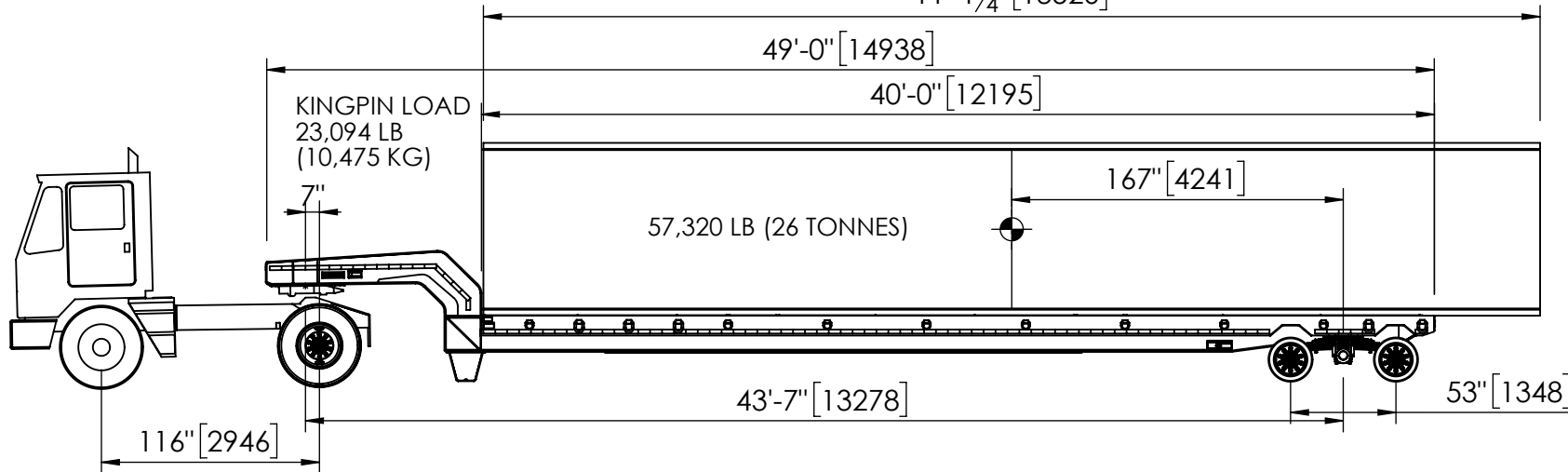

KINGPIN LOAD
23,094 LB
(10,475 KG)

57,320 LB (26 TONNES)

9,260 LB TARE 10,051 LB

1,393 LB PAYLOAD 21,700 LB

10,653 LB TOTAL 31,751 LB
(4,832 KG) (14,402 KG)

EMPTY TRAILER WEIGHT: 12,908 LB (5,855 KG)
TRUCK WEIGHT USED: 15,000 LB (6,803 KG)
TOTAL LOADED WEIGHT: 90,065 LB (40,853 KG)

TARE 8,597 LB

PAYLOAD 39,064 LB

TOTAL 47,661 LB
(21,618 KG)

MAGNUM TRAILER & EQUIPMENT INC.



FRACTIONS CHART

1/32	.03125	9/32	.28125	17/32	.53125	25/32	.78125
1/16	.0625	5/16	.3125	9/16	.5625	13/16	.8125
3/32	.09375	11/32	.34375	19/32	.59375	27/32	.84375
1/8	.125	3/8	.375	5/8	.625	7/8	.875
5/32	.15625	13/32	.40625	21/32	.65625	29/32	.90625
3/16	.1875	7/16	.4375	11/16	.6875	15/16	.9375
7/32	.21875	15/32	.46875	23/32	.71875	31/32	.96875
1/4	.25	1/2	.5	3/4	.75		

UNLESS OTHERWISE SPECIFIED
DIMENSIONS ARE IN INCHES
TOLERANCES ARE:

FRACTIONS	ANGLES
+/- 1/16"	+/- 1°
.XX"	.XXX"
+/- 0.03"	+/- 0.005"

DIMENSIONS TO SHARP POINTS

REV.	CHANGES OR ADDITIONS	DATE	REV. BY
SHEET NAME Sheet2		TITLE 40FT BRIDGE MAFI WITH GIRDERLOAD	
CURRENT CUSTOMER		STOCK NUMBER	VENDOR NUMBER
WO#		DRAWN BY HM	DRAWN DATE 8/22/2023
SCALE 1:90		MODELLER HM	DRAWING NUMBER AA-62427
			WEIGHT - LB. 0.0
			NUMBER OF SHEETS 1