

## EU TYPE-APPROVAL CERTIFICATE

Communication concerning the:

- EU type-approval,
- ~~extension of EU type approval,~~
- ~~refusal of EU type approval,~~
- ~~withdrawal of EU type approval,~~

of an ~~engine type~~/engine family <sup>(1)</sup> with regard to gaseous and particulate pollutant emission pursuant to Regulation (EU) 2016/1628, as last amended by ~~(Commission Delegated)~~ <sup>(1)</sup> Regulation (EU) 2020/1040 <sup>(1)(2)</sup> (of the European Parliament and of the Council) <sup>(1)</sup>

EU Type Approval No: e24\*2016/1628\*2020/1040EVI/D\*0453\*00

Reason for extension/refusal/withdrawal <sup>(1)</sup>:

- N/A

### SECTION I

- |       |  |  |
|-------|--|--|
| 1.1.  | Make (trade name(s) of manufacturer):  | <b>KOOP</b>  |
| 1.2.  | Commercial name(s) (if applicable):  | N/A  |
| 1.3.  | Company name and address of manufacturer:  | <b>Changzhou Koop Power Machinery Co., Ltd.<br/>NO.6 Hexiang Road, Wujin Economic Development Zone, Changzhou City, Jiangsu Province, China</b>            |
| 1.4.  | Name and address of manufacturer's authorised representative (if any):                     | <b>ZIPPER MASCHINEN GMBH<br/>Gewerbepark 84707 Schluslberg<br/>Austria</b>   |
| 1.5.  | Name(s) and address(es) of assembly/manufacture plant(s):                                  | <b>Same as above 1.3</b>   |
| 1.6.  | Engine type designation/engine family designation/FT <sup>(1)</sup> :                      | <b>Engine family name: KD15<br/>Parent engine: KD195FC-1<br/>Engine within family: KD195FC, KD192FC, KD192FC-1, KD188FC, KD188FC-1, KD186FC, KD186FC-1</b> |
| 1.7.  | Category and sub-category of the <del>engine type</del> /engine family <sup>(1)(4)</sup> : | <b>Category: NRE<br/>Sub-category: NRE-v-1</b>   |
| 1.8.  | Emissions durability period category:  | <b>Not Applicable/<del>Cat 1/Cat 2/Cat 3</del> <sup>(1)</sup></b>  |
| 1.9.  | Emissions stage:   | <b>V/ <del>SPE</del></b>   |
| 1.10. | Engine for snow throwers <sup>(5)</sup> :  | <b>Yes/No <sup>(1)</sup></b>   |



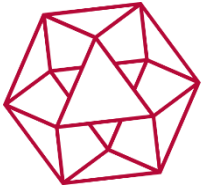

# NSAI

EU Type Approval No: e24\*2016/1628\*2020/1040EV1/D\*0453\*00

## SECTION II

- |    |   |   |
|----|---|---|
| 1. | Technical service responsible for carrying out the tests: | <b>TÜV Rheinland Kraftfahrt GmbH<br/>Am Grauen Stein<br/>D-51105 Köln<br/>Germany</b> |
| 2. | Date(s) of test report(s):                                | <b>10.05.2021</b>   |
| 3. | Number(s) of test report(s):                              | <b>85-2016/1628-253/21-00</b>   |

## SECTION III

The undersigned hereby certifies the accuracy of the manufacturer's description in the attached information document of the ~~engine type~~/engine family <sup>(1)</sup> described above, for which one or more representative samples, selected by the approval authority, have been submitted as prototypes and that the attached test results apply to the engine type/engine family <sup>(1)</sup>.

- |    |  |   |
|----|--|---|
| 1. | The <del>engine type</del> /engine family <sup>(1)</sup> meets/ <del>does not meet</del> <sup>(1)</sup> the requirements laid down in Regulation (EU) 2016/1628. |   |
| 2. | The approval is:   | <b><i>granted/extended/refused/withdrawn</i></b> <sup>(1)</sup> |
| 3. | The approval is granted in accordance with Article 35 of Regulation (EU) 2016/1628 and the validity of the approval is thus limited to dd/mm/yyyy <sup>(3)</sup> | <b>N/A</b>  |
| 4. | Restrictions to validity <sup>(3) (6)</sup> :  | <b>N/A</b>  |
| 5. | Exemptions applied <sup>(3) (6)</sup> :  | <b>N/A</b>  |
|    | Place:   | <b>Dublin.</b>  |
|    | Date:  | <b>15<sup>th</sup> June, 2021.</b>                              |

Name and signature  
(or visual representation of an  
'advanced electronic signature'  
according to Regulation (EU) No 910/2014, including data for verification):

### Attachments:

Information package  
Test report(s)

Where applicable, the name(s) and specimen(s) of the signature(s) of the person(s) authorised to sign statement of conformity and a statement of their position in the company Where applicable, a completed specimen of a statement of conformity

NB:  
If this model is used for EU type-approval of an engine as an exemption for new technologies or new concepts, pursuant to Article 35(4) of Regulation (EU) 2016/1628, the heading of the certificate shall read 'PROVISIONAL EU TYPE-APPROVAL CERTIFICATE VALID ONLY ON THE TERRITORY OF ... <sup>(7)</sup>'.





## Addendum

### PART A — CHARACTERISTICS OF THE ENGINE TYPE/ENGINE FAMILY <sup>(1)</sup>

2. Common design parameters of the ~~engine type~~/engine family <sup>(1)</sup>
- 2.1. Combustion Cycle: *four stroke cycle/two stroke cycle/rotary  
other: (describe) <sup>(1)</sup>*
- 2.2. Ignition Type: *Compression ignition/spark ignition <sup>(1)</sup>*
- 2.3.1. Position of the cylinders in the block: *V/in-line/radial/other(Single) <sup>(1)</sup>*
- 2.6. Main Cooling medium: *Air/Water/Oil <sup>(1)</sup>*
- 2.7. Method of air aspiration: *naturally aspirated/pressurecharged/  
pressure charged with charge cooler <sup>(1)</sup>*
- 2.8.1. Fuel Type(s): *Diesel (non-road gas-oil)/Ethanol for  
dedicated compression ignition engines  
(ED95)/Petrol (E10)/Ethanol(E85)/  
(Natural gas/Biomethane)/Liquid  
Petroleum Gas (LPG) <sup>(1)</sup>*
- 2.8.1.1. Sub Fuel type (Natural gas/Biomethane only): *Universal fuel — high calorific fuel (H-  
gas) and low calorific fuel (L-gas)/  
Restricted fuel — high calorific fuel (H  
gas)/Restricted fuel — low calorific fuel  
(L-gas)/Fuel specific (LNG);*
- 2.8.2. Fuelling arrangement: *Liquid-fuel only/Gaseous-fuel only/Dual-  
fuel type 1A/Dual-fuel type 1B/Dual-fuel  
type 2A/Dual-fuel type 2B/Dual-fuel  
type 3B <sup>(1)</sup>*
- 2.8.3. List of additional fuels compatible with use by the engine declared by the manufacturer in accordance with point 1 of Annex I to Delegated Regulation (EU) 2017/654 (provide reference to recognised standard or specification):
- 2.8.4. Lubricant added to fuel: *Yes/No <sup>(1)</sup>*
- 2.8.5. Fuel supply type: *Pump (high pressure) line and injector/in  
line pump or distributor pump/Unit  
injector/Common rail/Carburettor/port  
injector/direct injector/Mixing unit/  
other(specify) <sup>(1)</sup>*
- 2.9. Engine management systems: *mechanical/electronic control strategy <sup>(1)</sup>*



EU Type Approval No: e24\*2016/1628\*2020/1040EV1/D\*0453\*00

2.10.	Miscellaneous devices:	
2.10.1.	Exhaust gas recirculation (EGR):	<del>Yes/No</del> <sup>(1)</sup>
2.10.2.	Water injection:	<del>Yes/No</del> <sup>(1)</sup>
2.10.3.	Air injection:	<del>Yes/No</del> <sup>(1)</sup>
2.10.4.	Others (specify):	N/A
2.11.	Exhaust after-treatment system:	<del>Yes/No</del> <sup>(1)</sup>
2.11.1.	Oxidation catalyst:	<del>Yes/No</del> <sup>(1)</sup>
2.11.2.	DeNOx system with selective reduction of NOx (addition of reducing agent):	<del>Yes/No</del> <sup>(1)</sup>
2.11.3.	Other DeNOx systems:	<del>Yes/No</del> <sup>(1)</sup>
2.11.4.	Three-way catalyst combining oxidation and NOx reduction:	<del>Yes/No</del> <sup>(1)</sup>
2.11.5.	Particulate after-treatment system with passive regeneration:	<del>Yes/No</del> <sup>(1)</sup>
2.11.6.	Particulate after-treatment system with active regeneration:	<del>Yes/No</del> <sup>(1)</sup>
2.11.7.	Other particulate after-treatment systems:	<del>Yes/No</del> <sup>(1)</sup>
2.11.8.	Other after-treatment devices (specify):	N/A
2.11.9.	Other devices or features that have a strong influence on emissions (specify):	N/A





# NSAI

EU Type Approval No: e24\*2016/1628\*2020/1040EV1/D\*0453\*00

3. Essential characteristics of the engine type(s)

Item Number	Item Description	Parent Engine / Engine type	Engine types within the family (if applicable)
3.1.1.	Engine Type Designation:	<b>KD195FC-1</b>	*
3.1.2.	Engine type designation shown on engine mark: Yes/No <sup>(1)</sup>	<b>Yes</b>	*
3.1.3.	Location of the manufacturer's statutory marking:	<b>Refer to drawing No. 001</b>	*
3.2.1.	Declared rated speed (rpm):	<b>3000</b>	*
3.2.1.2.	Declared rated net Power (kW):	<b>7.5</b>	*
3.2.2.	Maximum power speed (rpm):	<b>3000</b>	*
3.2.2.2.	Maximum net power (kW):	<b>7.5</b>	*
3.2.3.	Declared maximum torque speed (rpm):	<b>2250</b>	*
3.2.3.2.	Declared maximum torque (Nm):	<b>27.5</b>	*
3.6.3.	Number of Cylinders:	<b>1</b>	*
3.6.4.	Engine total swept volume (cm <sup>3</sup> ):	<b>532</b>	*
3.8.5.	Device for recycling crankcase gases: Yes/No <sup>(1)</sup>	<b>Yes</b>	*
3.11.3.12.	Consumable reagent: Yes/No <sup>(1)</sup>	<b>No</b>	*
3.11.3.12.1.	Type and concentration of reagent needed for catalytic action:	<b>N/A</b>	*
3.11.3.13.	NOx sensor(s): Yes/No <sup>(1)</sup>	<b>No</b>	*
3.11.3.14.	Oxygen sensor: Yes/No <sup>(1)</sup>	<b>No</b>	*
3.11.4.7.	Fuel borne catalyst (FBC): Yes/No <sup>(1)</sup>	<b>No</b>	*



EU Type Approval No: e24\*2016/1628\*2020/1040EV1/D\*0453\*00

Particular conditions to be respected in the installation of the engine on non-road mobile machinery:

Item Number	Item Description	Parent Engine / Engine type	Engine types within the family (if applicable)
3.8.1.1.	Maximum allowable intake depression at 100 % engine speed and at 100 % load (kPa) with clean air cleaner:	<b>-1.5</b>	*
3.8.3.2.	Maximum charge air cooler outlet temperature at 100 % speed and 100 % load (deg. C):	<i>N/A</i>	*
3.8.3.3.	Maximum allowable pressure drop across charge cooler at 100 % engine speed and at 100 % load (kPa) (if applicable):	<i>N/A</i>	*
3.9.3.	Maximum permissible exhaust gas backpressure at 100 % engine speed and at 100 % load (kPa):	<b>0.5</b>	*
3.9.3.1	Location of measurement:	<b>outlet of muffler</b>	*
3.11.1.2.	Maximum temperature drop from exhaust system or turbine outlet to first exhaust after-treatment system (deg. C) if stated:	<i>N/A</i>	*
3.11.1.2.1.	Test conditions for measurement:	<i>N/A</i>	*

*\*For essential characteristics of the engine types with the engine family see information document KD15-1628-00 last dated 23.03.2021*

## PART B — TEST RESULTS

- 3.8. Manufacturer intends to use ECU torque signal for in-service monitoring: **Yes/No** <sup>(1)</sup>
- 3.8.1. Dynamometer torque greater than or equal to  $0,93 \times$  ECU torque: **Yes/No** <sup>(1)</sup>
- 3.8.2. ECU torque correction factor in case that dynamometer torque less than  $0,93 \times$  ECU torque: **N/A**

### 11.1. Cycle emissions results

Emissions	CO (g/kWh)	HC (g/kWh)	NOx (g/kWh)	HC+NOx (g/kWh)	PM (g/kWh)	PN #/kWh	Test Cycle <sup>(8)</sup>
NRSC final result with DF.	1.518	0.584	6.713	7.297	0.307	N/A	G2
NRTC Final test result with DF	-	-	-	-	-	-	-

*(\*) Optionally, as an alternative, any combination of values satisfying the equation  $(HC + NOx) \times CO^{0,784} \leq 8,57$  as well as the following conditions:  $CO \leq 20,6$  g/kWh and  $(HC + NOx) \leq 2,7$  g/kWh*

- 11.2. CO<sub>2</sub> result: **967.4 g/kWh**



EU Type Approval No: e24\*2016/1628\*2020/1040EV1/D\*0453\*00

- 11.3. In service monitoring reference values <sup>(9)</sup>
- 11.3.1. Reference work (kWh): *N/A*
- 11.3.2. Reference CO<sub>2</sub> mass (g): *N/A*

Explanatory notes to Annex IV:

*(Footnote markers, footnotes and explanatory notes not to be stated on the EU type-approval certificate)*

- <sup>(1)</sup> Strike out the unused options, or only show the used option(s).
- <sup>(2)</sup> Indicate only the latest amendment in case of an amendment of one or more Articles of Regulation (EU) 2016/1628, according to the amendment applied for the EU type-approval.
- <sup>(3)</sup> Delete this entry when not applicable.
- <sup>(4)</sup> Indicate the applicable option for the category and sub-category in accordance with entry 1.7 of the information document set out in Part A of Appendix 3 to Annex I.
- <sup>(5)</sup> Indicate whether the approval is for a NRS (< 19 kW) engine family consisting exclusively of engine types for snow throwers.
- <sup>(6)</sup> Applicable only for EU type-approval of an engine type or an engine family as an exemption for new technologies or new concepts, pursuant to Article 35 of Regulation (EU) 2016/1628.
- <sup>(7)</sup> Indicate the Member State.
- <sup>(8)</sup> Indicate the test cycle in accordance with the fifth column of the Tables set out in Annex IV to Regulation (EU) 2016/1628.
- <sup>(9)</sup> Only applicable to engines of sub-categories NRE-v-5 and NRE-v-6 tested on NRTC.





## Index to the Information Package

Date of issue:	<i>15<sup>th</sup> June, 2021.</i>
Date of latest amendment:	<i>N/A</i>
Reason for extension/revision:	<i>N/A</i>
1. Additional conditions, and advisory notes on legal alternatives.	
2. Test report(s)	
- numbers(s):	<i>85-2016/1628-253/21-00</i>
- date of issue:	<i>10.05.2021</i>
- date of latest amendment:	<i>N/A</i>
3. Information document	
- number(s):	<i>KD15-1628-00</i>
- date of issue:	<i>23.03.2021</i>
- date of latest amendment:	<i>N/A</i>
Documentation:	<i>59 pages</i>



EU Type Approval No: e24\*2016/1628\*2020/1040EV1/D\*0453\*00

Appendix: **Additional conditions, and advisory notes on legal alternatives**

A: Additional conditions:

1. The attached technical report, with any of its attachments, forms part of this Type Approval certificate.
2. Each type from series production shall be to the measurements specified in the attached drawings, and shall be manufactured only from the materials specified in the Approval documents.
3. Changes in the type are permitted only with the explicit permission of NSAI. Breaches of this requirement will lead to a withdrawal of the Type Approval, and in addition may be subject to criminal prosecution.
4. At regular intervals, any tests or associated checks prescribed by the applicable legislation to verify continued conformity with the approved type shall be carried out. The manufacturer shall demonstrate compliance with this by submitting to NSAI evidence of adequate arrangements and documented control plans for each type approved.
5. Any set of samples or test pieces showing evidence of non-conformity shall give rise to further sampling and testing and all steps shall be taken to restore conformity of production.
6. This Type Approval will expire when it is surrendered by the holder, or withdrawn by NSAI, or when the approved type no longer conforms to legal requirements. The recall of the Type Approval can be issued by NSAI when the conditions required for the issuing or continuation of the Type Approval are no longer current, or when the Approval holder is in breach of the duties attached to the Type Approval, or when it is established that the approved type no longer meets the requirements of traffic safety.
7. Changes in the company name, address or manufacturing site, as well as in any of the sales or other agents specified in the issuing of the approval must immediately be notified to NSAI.
8. The duties imposed by the issuing of this certificate are not transferable. The legal protection of third parties is not affected by this certificate.
9. When the manufacture or sale of the system, component or separate technical unit has not been started within one year of the date of issue of this certificate, then NSAI is to be informed. This requirement also applies when the manufacture or sale has been halted for more than one year, or when it ought to have been halted for more than one year. The initial commencement of manufacture or sale, or the resumption of manufacture or sale, shall then be notified to NSAI within one month of commencement or resumption.

B: Legal Options:

Any objection to the requirements set out in this certificate shall be made within one month of the date of issue. The objection shall be made, in writing, to NSAI in Dublin.



Manufacturer : Changzhou Koop Power Machinery Co., Ltd.  
 Engine type/ Engine family : KD15

## TEST REPORT

according to Regulation of the European Parliament and of the Council

**on requirements relating to gaseous and particulate pollutant emission limits and type-approval for internal combustion engines for non-road mobile machinery**

**(EU) 2016/1628**

including all amendments until

**(EU) 2020/1040**

Previously granted	
EU type – approval	: ---

Structure of report:

1. General Information
2. General engine information (test engine)
3. Documentation and information Check list (primary test only)
4. Reference fuel(s) used for test (complete relevant subparagraph(s))
5. Lubricant
6. Engine Speed
7. Engine Power
8. Conditions at test
9. Information concerning the conduct of the NRSC test:
10. Information concerning the conduct of the NRTC test (if applicable):
11. Final emissions results
12. Remark concerning extension
13. Remarks concerning tested object(s)
14. Appendices
15. Statement of conformity



Page 1 of 18

**Manufacturer** : Changzhou Koop Power Machinery Co., Ltd.  
**Engine type/ Engine family** : KD15

### 1. General information

- 1.1. Make (trade name of the manufacturer) : KOOP
- 1.2. Commercial name(s) (if applicable) : ---
- 1.3. Company name and address of manufacturer : Changzhou Koop Power Machinery Co., Ltd.  
NO.6 Hexiang Road, Wujin Economic Development Zone, Changzhou City, Jiangsu Province, China
- 1.4. Name of technical service : TÜV Rheinland Kraftfahrt GmbH
- 1.5. Address of technical service : Am Grauen Stein  
D-51105 Köln  
Germany
- 1.6. Location of test : Vehicle Products Laboratory of Jiangsu University
- 1.7. Date of test : April 29, 2021
- 1.8. Test report number : 85-2016/1628-253/21-00
- 1.9. Information document reference number (if available) : KD15-1628-00
- 1.10. Test report type : Primary test/~~additional test~~/~~supplementary test~~
- 1.10.1. Description of the purpose of the test : Type approval test
- 1.11. Remark : N/A

### 2. General engine information (test engine)

- 2.1. ~~Engine type designation~~/engine family designation/~~FT~~ : Engine family name: KD15  
Parent engine: KD195FC-1  
Engine within family: KD195FC, KD192FC, KD192FC-1, KD188FC, KD188FC-1, KD186FC, KD186FC-1
- 2.2. Engine identification number : KDFD03020650
- 2.3. Engine Category and subcategory : Category: NRE  
Sub-category: NRE-v-1
- 2.4. Condition of object(s) : New, ~~used~~, ~~pretested~~
- 2.5. Worst case selection : Test was carried out on parent engine.
- 2.6. Remark : ---

### 3. Documentation and information Check list (primary test only)

- 3.1. Engine mapping documentation reference : See information folder No.: KD15-1628-00
- 3.2. Deterioration factor determination documentation reference : See information folder No.: KD15-1628-00

**Manufacturer** : Changzhou Koop Power Machinery Co., Ltd.  
**Engine type/ Engine family** : KD15

- 3.3. Infrequent regeneration factors determination documentation reference, where applicable : N/A
- 3.4. NOx control diagnostic demonstration documentation reference, where applicable : N/A
- 3.5. Particulate control diagnostic demonstration documentation reference, where applicable : N/A
- 3.6. For engine types and engine families that use an ECU as part of the emission control system anti-tampering declaration documentation reference : N/A
- 3.7. For engine types and engine families that use mechanical devices as part of the emission control system anti-tampering and adjustable parameters declaration and demonstration documentation reference : See information folder No.: KD15-1628-00
- 3.8. Manufacturer intends to use ECU torque signal for in-service monitoring : Yes/No
- 3.8.1. Dynamometer torque greater than or equal to  $0,93 \times$  ECU torque : Yes/No
- 3.8.2. ECU torque correction factor in case that dynamometer torque less than  $0,93 \times$  ECU torque : N/A
4. **Reference fuel(s) used for test (complete relevant subparagraph(s))**
- 4.1. Liquid fuel for spark-ignition engines : N/A
- 4.2. Liquid fuel for compression-ignition engines
- 4.2.1. Make : Sinopec
- 4.2.2. Type : Diesel (non-road gas-oil)
- 4.2.3. Cetane number : 54.6
- 4.2.4. Fame content (%) : <0.1%
- 4.2.5. Density at 15 Deg.C (kg/m<sup>3</sup>) : 840.7
- 4.3. Gaseous fuel — LPG : N/A
- 4.4. Gaseous fuel- Methane/biomethane : N/A
- 4.5. Dual fuel engine (in addition to relevant sections above) : N/A
5. **Lubricant**
- 5.1. Make(s) : CHANGCHENG
- 5.2. Type(s) : CD



**Manufacturer** : Changzhou Koop Power Machinery Co., Ltd.  
**Engine type/ Engine family** : KD15

- 5.3. Viscosity-Dynamic : 15W/40
- 5.4. Lubricant and fuel are mixed : ~~Yes~~/ No
- 5.4.1. Percentage of oil in mixture : N/A
- 6. **Engine Speed**
- 6.1. 100 % speed (rpm) : 3000
- 6.1.1. 100 % speed determined by : ~~Declared rated speed/Declared maximum test speed (MTS)/Measured MTS~~
- 6.1.2. Adjusted MTS if applicable (rpm) : N/A
- 6.2. Intermediate speed (rpm) : N/A
- 6.2.1. Intermediate speed determined by : ~~Declared intermediate speed/Measured intermediate speed/60 % of 100 % speed/75 % of 100 % speed/85 % of 100 % speed~~
- 6.3. Idle speed (rpm) : 1300
- 7. **Engine Power**
- 7.1. Engine driven equipment (if applicable)
- 7.1.1. Power absorbed at indicated engine speeds by necessary auxiliaries for engine operation that cannot be fitted for the test (as specified by the manufacturer) to be stated in Table 1:

**Table 1 Power absorbed by engine auxiliaries**

Auxiliary type and identifying details	Power absorbed at indicated speed (kW) (complete relevant columns)						
	Idle	63%	80%	91%	Inter-mediate	Max. power	100%
---	---	---	---	---	---	---	---
---	---	---	---	---	---	---	---
---	---	---	---	---	---	---	---
Total (P <sub>f,i</sub> ) (kW):	---	---	---	---	---	---	---

- 7.1.2. Power absorbed at indicated engine speeds by auxiliaries linked with the operation of the non-road mobile machinery that cannot be removed for the test (as specified by the manufacturer) to be stated in Table 2:

**Table 2 Power absorbed by non-road mobile machinery auxiliaries**

Auxiliary type and identifying details	Power absorbed at indicated speed (kW) (complete relevant columns)						
	Idle	63%	80%	91%	Inter-mediate	Max. power	100%
---	---	---	---	---	---	---	---
---	---	---	---	---	---	---	---
---	---	---	---	---	---	---	---
Total (P <sub>r,i</sub> ) (kW):	---	---	---	---	---	---	---

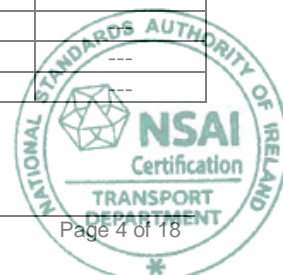

**Manufacturer** : Changzhou Koop Power Machinery Co., Ltd.  
**Engine type/ Engine family** : KD15

7.2. Engine net power to be stated in Table 3:

**Table 3 Engine net power**

Condition	Power setting at indicated engine speed (kW) (complete relevant columns)		
	Intermediate	Max. power	100%
Maximum power measured at specified test speed ( $P_{m,i}$ ) (kW)	---	---	7.5
Total auxiliary power from table 1 ( $P_{f,i}$ )	---	---	---
Total auxiliary power from table 2 ( $P_{r,i}$ )	---	---	---
Net engine power (kW) $P_i = P_{m,i} - P_{f,i} + P_{r,i}$	---	---	7.5

8. **Conditions at test**

- 8.1.  $f_a$  within range 0.93 to 1.07 : Yes / No
- 8.1.1. If  $f_a$  is not within specified range state altitude of test facility and dry atmospheric pressure : N/A
- 8.2. Applicable intake air temperature range : 20 to 30/0 to 5 (snow throwers only)/ 5 to 15 (snowmobiles only)/ 20 to 35 (NRE greater than 560 kW only)

9. **Information concerning the conduct of the NRSC test**

9.1. Cycle (mark cycle used with X) to be stated in Table 4

**Table 4 NRSC test cycle**

Cycle	C1	C2	D2	E2	E3	F	G1	G2	G3	H
Discrete mode	---	---	---	---	---	---	---	X	---	---
RMC	---	---	---	---	---	---	---	---	---	---

Test length of each mode : 10 minutes

9.2. Dynamometer setting (kW) to be stated in Table 5

**Table 5 Dynamometer setting**

% Load at point or % of rated power (as applicable)	Dynamometer setting (kW) at various engine speeds taking account of net engine power <sup>(1)</sup> from Table 3 (complete relevant columns)					
	Idle	63%	80%	91%	Inter-mediate	100%
0%	0	---	---	---	---	---
5%	---	---	---	---	---	---
10%	---	---	---	---	---	0.75
25%	---	---	---	---	---	1.86
50%	---	---	---	---	---	3.75
75%	---	---	---	---	---	5.64
100%	---	---	---	---	---	7.48

(1) The dynamometer setting shall be determined using the procedure set out in point 7.7.1.3 of Annex VI to Delegated Regulation (EU) 2018/989. The auxiliary power in that point shall be determined using the total values set out in Tables 1 and 2 of this Appendix.



Manufacturer : Changzhou Koop Power Machinery Co., Ltd.  
 Engine type/ Engine family : KD15

## 9.3. NRSC Emissions results

9.3.1. Deterioration Factor (DF) : ~~calculated~~/assigned

9.3.2. DF values and the cycle weighted emissions results to be stated in Table 6:

Note: In the event that a discrete mode NRSC is run where the  $K_{ru}$  or  $K_{rd}$  factors have been established for individual modes then a table showing each mode and the applied  $K_{ru}$  or  $K_{rd}$  should replace the shown table

**Table 6 NRSC cycle DF values and weighted emissions results**

DF	CO	HC	NO <sub>x</sub>	HC+NO <sub>x</sub> *	PM	PN
mult/add	1.3	1.3	1.15	---	1.05	---
Emissions	CO (g/kWh)	HC (g/kWh)	NO <sub>x</sub> (g/kWh)	HC+NO <sub>x</sub> (g/kWh)	PM (g/kWh)	PN #/kWh
Test result with/without regeneration	1.168	0.449	5.837	6.285	0.292	---
$k_{ru}/k_{rd}$ mult/add	---	---	---	---	---	---
test result with IRAF	---	---	---	---	---	---
<b>Final test result with DF</b>	1.518	0.584	6.713	7.297	0.307	---

\* No DF given in the regulations.

9.3.3. Cycle weighted CO<sub>2</sub> (g/kWh) : 967.49.3.4. Cycle weighted NH<sub>3</sub> (ppm) : N/A

9.4. Additional control area test points (if applicable) to be stated in Table 7 : N/A

**Table 7 Additional control area test points**

Emissions at test point	Engine Speed	Load (%)	CO (g/kWh)	HC (g/kWh)	NO <sub>x</sub> (g/kWh)	HC+NO <sub>x</sub> (g/kWh)	PM (g/kWh)	PN n/kWh
Test result 1	---	---	---	---	---	---	---	---
Test result 2	---	---	---	---	---	---	---	---
Test result 3	---	---	---	---	---	---	---	---

## 9.5. Sampling systems used for the NRSC test

9.5.1. Gaseous emissions : Analysis system: HORRIBA MEXA-7200D

9.5.2. PM : PM Analysis system: AVL SPC472

9.5.2.1. Method : single/multiple filter

9.5.3. Particle number : N/A



Manufacturer : Changzhou Koop Power Machinery Co., Ltd.  
 Engine type/ Engine family : KD15

10. Information concerning the conduct of the NRTC test (if applicable) : N/A

10.1. Cycle (mark cycle with X) to be stated in Table 8

Table 8 NRTC test cycle

NRTC	---
LSI-NRTC	---

10.2. Transient test deterioration factors

10.2.1. Deterioration Factor (DF) : ~~calculated~~/fixed

10.2.2. DF values and the emissions results to be stated in Table 9 or Table 10

10.3. NRTC emission results

Table 9 DF values and the emissions results for NRTC

DF	CO	HC	NO <sub>x</sub>	HC+NO <sub>x</sub> *	PM	PN
mult/add	1.3	1.3	1.15	---	1.05	1.00
Emissions	CO (g/kWh)	HC (g/kWh)	NO <sub>x</sub> (g/kWh)	HC+NO <sub>x</sub> (g/kWh)	PM (g/kWh)	PN #/kWh
Cold start	---	---	---	---	---	---
Hot start test result with/ <del>without</del> regeneration	---	---	---	---	---	---
Weighted test result	---	---	---	---	---	---
kru/krd mult/add	---	---	---	---	---	---
Weighted test result with IRAFs	---	---	---	---	---	---
<b>Final test result with DF</b>	---	---	---	---	---	---

\* No DF given in the regulations.

10.3.1. Hot cycle CO<sub>2</sub> (g/kWh) : N/A

10.3.2. Cycle average NH<sub>3</sub> (ppm) : N/A

10.3.3. Cycle work for hot start test (kWh) : N/A

10.3.4. Cycle CO<sub>2</sub> for hot start test (g) : N/A

10.4. LSI-NRTC emission results : N/A

10.5. Sampling system used for the transient test

10.5.1. Gaseous emissions : N/A

10.5.2. PM : N/A



**Manufacturer** : Changzhou Koop Power Machinery Co., Ltd.  
**Engine type/ Engine family** : KD15

10.5.3. Particle number : N/A

11. **Final emissions results**

11.1. Cycle emissions results to be stated in Table 11.

**Table 11 Final emissions results**

Emissions	CO (g/kWh)	HC (g/kWh)	NO <sub>x</sub> (g/kWh)	HC+NO <sub>x</sub> (g/kWh)	PM (g/kWh)	PN #/kWh	Test Cycle <sup>(1)</sup>
NRSC final result with DF <sup>(2)</sup>	1.518	0.584	6.713	7.297	0.307	---	G2
Final transient test result with DF <sup>(3)</sup>	---	---	---	---	---	---	---

11.2. CO<sub>2</sub> result <sup>(4)</sup> (g/kWh) : 967.4

11.3. In service monitoring reference values <sup>(5)</sup> : N/A

11.3.1. Reference work (kWh) <sup>(6)</sup> : N/A

11.3.2. Reference CO<sub>2</sub> mass (g) <sup>(7)</sup> : N/A

11.4. Additional information : The results of the test refer exclusively to the object(s) mentioned under section 2.2 of this report.

12. **Remark concerning extension** : ~~The engine type has been tested according to the modification(s) mentioned in appendix 0. The new parts meet the requirements of the directive. An actual practical test of the engine was not necessary. The results of the previous test(s) are still valid.~~

13. **Remarks concerning tested object(s)** : All version of the type as stated in the information document are covered with the tested version(s) and test object(s) respectively.

<sup>(1)</sup> For NRSC note the cycle indicated in point 9.1 (Table 4); for NRTC note cycle indicated in point 10.1 (Table 8).

<sup>(2)</sup> Copy the "Final test result with DF" results from Table 6.

<sup>(3)</sup> Copy "Final test result with DF" results from Table 9 or 10, as applicable.

<sup>(4)</sup> For an engine type or engine family that is tested on both the NRTC and NRSC, indicate the hot cycle CO<sub>2</sub> emissions values from the NRTC noted in point 10.3.4 or the CO<sub>2</sub> emissions values from the LSI-NRTC noted in point 10.4.4. For an engine only tested on an NRSC indicate the CO<sub>2</sub> emissions values given in that cycle noted in point 9.3.3.

<sup>(5)</sup> Only applicable to engines of sub-categories NRE-v-5 and NRE-v-6 tested on NRTC.

<sup>(6)</sup> Indicate the cycle work for hot start test value from the NRTC noted in point 10.3.3.

<sup>(7)</sup> Indicate the cycle CO<sub>2</sub> for hot start test value from the NRTC noted in point 10.3.4.



**Manufacturer** : Changzhou Koop Power Machinery Co., Ltd.  
**Engine type/ Engine family** : KD15

14. **Appendices**

Appendix 0 List of modification  
Appendix L Technical information for the EU type-approval certificate  
Information folder No.: KD15-1628-00

15. **Statement of conformity**

The section 1.9 mentioned information document and the type described in that comply with the requirements mentioned on page 1. The mentioned test results refer to the ~~vehicle(s)~~/object(s) described under point 2.1 of this report. With regard to the required level of performance to be achieved, the tested samples were representative for the type to be approved (see section 2.5).

Engineering Center Shanghai, May 10, 2021

CGC

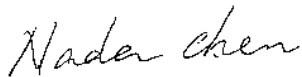

Nada Chen

Expert Technical Service



Page 9 of 18

Manufacturer : Changzhou Koop Power Machinery Co., Ltd.  
Engine type/ Engine family : KD15

List of modifications

Appendix 0

Correction of : ---

Modification of : ---

Addition of : ---

Deletion of : ---



**Manufacturer** : Changzhou Koop Power Machinery Co., Ltd.  
**Engine type/ Engine family** : KD15

**Technical information for the EU type-approval certificate**
**Appendix L**

 Communication concerning the <sup>(1)</sup>:

EU type-approval  
~~extension of EU type approval~~  
~~refusal of EU type approval~~  
~~withdrawal of EU type approval~~

 of an ~~engine type/~~ engine family<sup>(1)</sup> with regard to gaseous and particulate pollutant emission pursuant to Regulation (EU) 2016/1628, as last amended by (Commission Delegated)<sup>(1)</sup> Regulation (EU)2020/1040<sup>(1)</sup> (of the European Parliament and of the Council)<sup>(1)</sup>

 EU type-approval number<sup>(3)</sup>: e24\*2016/1628\*2020/1040\*EV1/D\*xxxx\*00

 Reason for extension/~~refusal/withdrawal~~<sup>(1)</sup>: Not applicable

## SECTION I

- |              |   |  |
|--------------|---|--|
| <b>1.1.</b>  | Make (trade name(s) of manufacturer):   | KOOP   |
| <b>1.2.</b>  | Commercial name(s) (if applicable):   | not applicable   |
| <b>1.3.</b>  | Company name and address of manufacturer:   | Changzhou Koop Power Machinery Co., Ltd.<br>NO.6 Hexiang Road, Wujin Economic Development Zone,<br>Changzhou City, Jiangsu Province, China.          |
| <b>1.4.</b>  | Name and address of manufacturer's authorised representative (if any):                        | ZIPPER MASCHINEN GMBH<br>Gewerbepark 84707 Schluslberg Austria   |
| <b>1.5.</b>  | Name(s) and address(es) of assembly/ <del>manufacture</del> plant(s):                         | Changzhou Koop Power Machinery Co., Ltd.<br>NO.6 Hexiang Road, Wujin Economic Development Zone,<br>Changzhou City, Jiangsu Province, China.          |
| <b>1.6.</b>  | <del>Engine type designation/</del> engine family designation/ <del>FT</del> <sup>(1)</sup> : | Engine family name: KD15<br>Parent engine: KD195FC-1<br>Engine within family: KD195FC, KD192FC, KD192FC-1,<br>KD188FC, KD188FC-1, KD186FC, KD186FC-1 |
| <b>1.7.</b>  | Category and sub-category of the engine type/ <del>engine family</del> <sup>(1)(4)</sup> :    | Category: NRE<br>Sub-category: NRE-v-1   |
| <b>1.8.</b>  | Emissions durability period category:   | not applicable/ <del>Cat 1/Cat 2/Cat 3</del> <sup>(1)</sup>  |
| <b>1.9.</b>  | Emissions stage:  | V/ <del>Special Purpose Engine (SPE)</del>   |
| <b>1.10.</b> | Engine for snow throwers <sup>(5)</sup> :   | <del>Yes</del> /No <sup>(1)</sup>  |



**Manufacturer** : Changzhou Koop Power Machinery Co., Ltd.  
**Engine type/ Engine family** : KD15

## SECTION II

1. Technical service responsible for carrying out the test(s): TÜV Rheinland Kraftfahrt GmbH  
Am Grauen Stein  
D-51105 Köln  
Germany
2. Date(s) of the test report(s): May 10, 2021
3. Number(s) of the test report(s): 85-2016/1628-253/21-00

## SECTION III

The undersigned hereby certifies the accuracy of the manufacturer's description in the attached information document of the ~~engine type~~ engine type/engine family<sup>(1)</sup> described above, for which one or more representative samples, selected by the approval authority, have been submitted as prototypes and that the attached test results apply to the ~~engine type~~ engine type/engine family<sup>(1)</sup>.

1. The ~~engine type~~ engine type/engine family<sup>(1)</sup> meets/~~does not meet~~<sup>(1)</sup> the requirements laid down in Regulation (EU) 2016/1628.
2. The approval is ~~granted/extended/refused/withdrawn~~<sup>(1)</sup>

Place :

Date:

Name and signature (or visual representation of an 'advanced electronic signature' according to Regulation (EU) No 910/2014, including data for verification):

**Attachments :**

- Information package
- Test report(s)
- Where applicable, the name(s) and specimen(s) of the signature(s) of the person(s) authorised to sign statement of conformity and a statement of their position in the company
- Where applicable, a completed specimen of a statement of conformity

NB:

If this model is used for type-approval of an engine as an exemption for new technologies or new concepts, pursuant to Article 35(4) of Regulation (EU) 2016/1628, the heading of the certificate shall read 'PROVISIONAL EU TYPE-APPROVAL CERTIFICATE VALID ONLY ON THE TERRITORY OF ...<sup>(7)</sup>'.



Page 12 of 18

**Manufacturer** : Changzhou Koop Power Machinery Co., Ltd.  
**Engine type/ Engine family** : KD15

## Addendum

EU type-approval number:	e24*2016/1628*2020/1040*EV1/D*xxxx*00
Part A – Characteristics of the <del>engine type</del> /engine family <sup>(1)</sup>	
<b>2. Common design parameters of the <del>engine type</del>/engine family<sup>(1)</sup></b>	
<b>2.1. Combustion Cycle:</b>	Four stroke cycle/ <del>Two stroke cycle</del> /Rotary/ <del>Other</del> : ..... (describe) <sup>(1)</sup>
<b>2.2. Ignition Type:</b>	Compression ignition/ <del>Spark ignition</del> <sup>(1)</sup>
<b>2.3.1. Position of the cylinders in the block:</b>	Single/V/ <del>In line</del> /radial/ <del>other</del> (describe) <sup>(1)</sup> : Single
<b>2.6. Main Cooling medium:</b>	Air/ <del>Water</del> / <del>Oil</del> <sup>(1)</sup>
<b>2.7. Method of air aspiration:</b>	Naturally aspirated/ <del>Pressure charged</del> / <del>Pressure charged with charge cooler</del> <sup>(1)</sup>
<b>2.8.1. Fuel Type(s):</b>	Diesel (non-road gas-oil)/ <del>Ethanol for dedicated compression ignition engines (E10)</del> /Petrol (E10)/ <del>Ethanol (E85)</del> /Natural gas/ <del>Biomethane</del> /Liquid Petroleum Gas (LPG) <sup>(1)</sup>
<b>2.8.1.1. Sub Fuel type (Natural gas/Biomethane only):</b>	Universal fuel – high calorific fuel (H-gas) and low calorific fuel (L-gas)/Restricted fuel – high calorific fuel (H-gas)/Restricted fuel – low calorific fuel (L-gas)/Fuel specific (LNG)
<b>2.8.2. Fuelling arrangement:</b>	Liquid-fuel only/ <del>Gaseous fuel only</del> /Dual fuel type 1A/ <del>Dual fuel type 1B</del> / <del>Dual fuel type 2A</del> / <del>Dual fuel type 2B</del> / <del>Dual fuel type 3B</del> <sup>(1)</sup>
<b>2.8.3. List of additional fuels compatible with use by the engine declared by the manufacturer in accordance with point 1. of Annex I to Regulation (EU) 2018/989 on technical and general requirements (provide reference to recognised standard or specification):</b>	N/A
<b>2.8.4. Lubricant added to fuel:</b>	Yes/ <del>No</del> <sup>(1)</sup>
<b>2.8.5. Fuel supply type:</b>	Pump (high pressure) line and injector/ <del>in-line pump or distributor pump</del> /Unit injector/ <del>Common rail</del> /Carburettor/ <del>port injector</del> / <del>direct injector</del> /Mixing unit/ <del>other</del> (specify) <sup>(1)</sup>
<b>2.9. Engine management systems:</b>	Mechanical/ <del>Electronic control strategy</del> <sup>(1)</sup>
<b>2.10. Miscellaneous devices:</b>	Yes/ <del>No</del> <sup>(1)</sup>
<b>2.10.1. Exhaust gas recirculation:</b>	Yes/ <del>No</del> <sup>(1)</sup>
<b>2.10.2. Water injection:</b>	Yes/ <del>No</del> <sup>(1)</sup>



**Manufacturer** : Changzhou Koop Power Machinery Co., Ltd.  
**Engine type/ Engine family** : KD15

2.10.3.	Air injection:	<del>Yes</del> /No <sup>(1)</sup>
2.10.4.	Others (specify):	N/A
2.11.	<b>Exhaust after-treatment system:</b>	<b>Yes</b> / <del>No</del> <sup>(1)</sup>
2.11.1.	Oxidation catalyst:	<del>Yes</del> /No <sup>(1)</sup>
2.11.2.	DeNOx system with selective reduction of NOx (addition of reducing agent):	<del>Yes</del> /No <sup>(1)</sup>
2.11.3.	Other DeNOx systems:	<del>Yes</del> /No <sup>(1)</sup>
2.11.4.	Three-way catalyst combining oxidation and NOx reduction:	<del>Yes</del> /No <sup>(1)</sup>
2.11.5.	Particulate trap with passive regeneration:	<del>Yes</del> /No <sup>(1)</sup>
2.11.6.	Particulate trap with active regeneration:	<del>Yes</del> /No <sup>(1)</sup>
2.11.7.	Other particulate after-treatment systems:	<del>Yes</del> /No <sup>(1)</sup>
2.11.8.	Other after-treatment devices (specify):	<del>Yes</del> /No <sup>(1)</sup>
2.11.9.	Other devices or features that have a strong influence on emissions (specify):	N/A



**Manufacturer** : Changzhou Koop Power Machinery Co., Ltd.  
**Engine type/ Engine family** : KD15

### 3. ESSENTIAL CHARACTERISTICS OF THE ENGINE TYPE(S)

Item Number	Item Description	Parent engine	Engine types within the engine family (if applicable)							
		Type 1	Type 2	Type 3	Type 4	Type 5	Type 6	Type 7	Type 8	
3.1.1.	Engine type designation	KD195FC-1	KD195FC	KD192FC	KD192FC-1	KD188FC	KD188FC-1	KD186FC	KD186FC-1	
3.1.2.	Engine type designation shown on engine marking:	Yes	←	←	←	←	←	←	←	
3.1.3.	Location of the statutory marking:	Refer to drawing No. 001	←	←	←	←	←	←	←	
3.2.1.	Declared rated speed (rpm):	3000	3600	3600	3000	3600	3000	3600	3000	
3.2.1.2.	Declared rated net power (kW):	7.5	7.9	7.5	7.0	6.7	6.4	6.6	5.7	
3.2.2.	Maximum power speed(rpm):	Same as above 3.2.1.	←	←	←	←	←	←	←	
3.2.2.2.	Maximum net power (kW):	Same as above 3.2.1.2.	←	←	←	←	←	←	←	
3.2.3.	Declared maximum torque speed (rpm):	2250	2700	2700	2250	2700	2250	2700	2250	
3.2.3.2.	Declared maximum torque (Nm):	27.5	24.1	22.9	25.6	20.4	23.4	20.1	20.9	
3.6.3.	Number of cylinders:	1	←	←	←	←	←	←	←	
3.6.4	Engine total swept volume (cm <sup>3</sup> ):	532	532	499	499	456	456	418	418	
3.8.5.	Device for recycling crankcase gases: Yes/No	Yes	←	←	←	←	←	←	←	
3.11.3.12.	Consumable reagent: Yes/No	No	←	←	←	←	←	←	←	

**Manufacturer** : Changzhou Koop Power Machinery Co., Ltd.  
**Engine type/ Engine family** : KD15

3.11.3.12.1.	Type and concentration of reagent needed for catalytic action:	N/A	←	←	←	←	←	←	←
3.11.3.13.	NO <sub>x</sub> sensor(s): Yes/No	No	←	←	←	←	←	←	←
3.11.3.14.	Oxygen sensor(s): Yes/No	No	←	←	←	←	←	←	←
3.11.4.7.	Fuel borne catalyst (FBC): Yes/No	No	←	←	←	←	←	←	←

Particular conditions to be respected in the installation of the engine on machinery:									
3.8.1.	Maximum allowable intake depression at 100% engine speed and at 100% load (kPa)	-1.5	←	←	←	←	←	←	←
3.8.3.2.	Maximum charge air cooler outlet temperature at 100% speed and 100% load (deg. °C):	N/A	←	←	←	←	←	←	←
3.8.3.3.	Maximum allowable pressure drop across charge cooler at 100% engine speed and at 100% load (kPa):	N/A	←	←	←	←	←	←	←
3.9.3.	Maximum permissible exhaust backpressure at 100% engine speed and at 100% load (kPa):	0.5	←	←	←	←	←	←	←
3.9.3.1.	Location of measurement:	outlet of muffler	←	←	←	←	←	←	←
3.11.1.2.	Maximum temperature drop from exhaust or turbine outlet to first after-treatment device (deg. °C) if stated:	N/A	←	←	←	←	←	←	←
3.11.1.2.1.	Test conditions for measurement:	N/A	←	←	←	←	←	←	←

**Manufacturer** : Changzhou Koop Power Machinery Co., Ltd.  
**Engine type/ Engine family** : KD15

Part B – Test results

- 3.8. Manufacturer intends to use Electronic Control Unit (ECU) torque signal for in-service monitoring: Yes/No<sup>(1)</sup>
- 3.8.1. Dynamometer torque greater than or equal to 0.93x Electronic Control Unit (ECU) torque: Yes/No<sup>(1)</sup>
- 3.8.2. Electronic Control Unit (ECU) torque correction factor in case that dynamometer torque less than 0.93x Electronic Control Unit (ECU) torque: Not applicable

11.1. Cycle emissions results

Emissions	CO (g/kWh)	HC (g/kWh)	NO <sub>x</sub> (g/kWh)	HC+NO <sub>x</sub> (g/kWh)	PM (g/kWh)	PN #/kWh	Test Cycle <sup>(8)</sup>
NRSC final result with DF	1.518	0.584	6.713	7.297	0.307	---	G2
NRTC Final test result with DF	---	---	---	---	---	---	---

- 11.2. CO<sub>2</sub> result (g/kWh): 967.4
- 11.3. In service monitoring reference values <sup>(9)</sup>
- 11.3.1. Reference work (kWh): N/A
- 11.3.2. Reference CO<sub>2</sub> mass (g): N/A

**Manufacturer** : Changzhou Koop Power Machinery Co., Ltd.  
**Engine type/ Engine family** : KD15

- 
- (1) Strike out the unused options, or only show the used option(s).
  - (2) Indicate only the latest amendment in case of an amendment of one or more Articles of Regulation (EU) 2016/1628, according to the amendment applied for the EU type-approval.
  - (3) Delete this entry when not applicable.
  - (4) Indicate the applicable option for the category and sub-category in accordance with entry 1.7. of the information document set out in Part A of Appendix 3 to Annex I.
  - (5) Indicate whether the approval is for a NRS (<19 kW) engine family consisting exclusively of engine types for snow throwers.
  - (6) Applicable only for type-approval of an engine type or an engine family as an exemption for new technologies or new concepts, pursuant to Article 35 of Regulation (EU) 2016/1628.
  - (7) Indicate the Member State.
  - (8) Indicate the test cycle in accordance with the fifth column of the Tables set out in Annex IV to Regulation (EU) 2016/1628.
  - (9) Only applicable to engines of sub-categories NRE-v-5 and NRE-v-6 tested on NRTC.

1.1. Contents

1.1.	Contents	1
1.2.	Declaration by manufacturer on compliance with Regulation (EU) 2016/1628	2
Part A	General information	3
Part B	Common design parameters of engine family	4-5
Part C	Essential characteristics of the engine type(s)	6-22
	Photographs of the engine	23
	Content of drawings	

Drawing No.	Drawing subject	Page
00A	Photographs of the engine	23
001	Position of statutory marking and engine identification number.	25
002	Combustion chamber, valve and port configuration	26
003	piston	27
004	Fuel feed/ injection system	28
005	Valve timing	29
006	Device for recycling crankcase gases	30
007	Air filter/ inlet path	31
008	Exhaust System	32
009	Catalyst	33

1.3.	Manufacturer's statement on the compliance of the engine type or engine family with the exhaust emission limits use fuels other than the reference fuels	34
1.4.	Overview of the emission control strategy for electronically controlled engines	34
1.5.	The functional operational characteristics of the NOx control measures and inducement system	34
1.6.	The functional operational characteristics of the particulate control measures	34
1.7.	Manufacturer's declaration, and supporting test reports or data, on deterioration factors	35
1.8.	Manufacturer's declaration, and supporting test reports or data, of the infrequent regeneration adjustment factors	36
1.9.	Declaration by manufacturer on prevention of tampering	37
1.10.	The physical connector required to receive the torque signal from the engine Electronic control Unit (ECU) during the in-service monitoring test	39
1.11.	A list of scheduled emission-related maintenance requirements and the period at which each should occur including any scheduled exchange of critical emission-related components	40

REVISION(S) HISTORY



1.2. Declaration by manufacturer on compliance with Regulation (EU) 2016/1628

The undersigned (full name and position): YULEI JIANG/Manager

Hereby declares that the following engine type/engine family complies in all respects with the requirements of Regulation (EU) 2016/1628 of the European Parliament and of the Council, Commission Delegated Regulation (EU) 2018/989, Commission Delegated Regulation(EU)2018/987 and Commission Implementing Regulation (EU) 2018/988 and does not use any defeat strategy.

All emission control strategies comply, where applicable, with the requirements for Base Emission Control Strategy(BECS) and Auxiliary Emission Control Strategy(AECS) set-out in section 2 of Annex IV to Delegated Regulation(EU)2018/989, and have been disclosed in accordance with that Annex and with Annex I to Implementing Regulation (EU) 2018/988.

- 1.1. Make (trade name(s) of manufacturer) : KOOP
- 1.2. Commercial name(s) (if applicable): : N/A.
- 1.3. Company name and address of manufacturer : Changzhou Koop Power Machinery Co., Ltd.  
NO.6 Hexiang Road, Wujin Economic Development Zone, Changzhou City, Jiangsu Province, China
- 1.4. Name and address of manufacturer's authorized representative (if any) : ZIPPER MASCHINEN GMBH  
Gewerbepark 84707 Schlusberg Austria
- 1.6. ~~Engine type designation~~/engine family designation/~~ET~~ : Engine family name: KD15  
Parent engine: KD195FC-1  
Engine within family: KD195FC, KD192FC, KD192FC-1, KD188FC, KD188FC-1, KD186FC, KD186FC-1

Sincerely yours

Place: Changzhou, Jiangsu

Date: 2021-03-31

Signature: YULEI JIANG



**Part A**

**1. GENERAL INFORMATION**

- 1.1. Make (trade name(s) of manufacturer) : KOOP
- 1.2. Commercial name(s) (if applicable) : N/A
- 1.3. Company name and address of manufacturer : Changzhou Koop Power Machinery Co., Ltd.  
 NO.6 Hexiang Road, Wujin Economic Development Zone, Changzhou City, Jiangsu Province, China
- 1.4. Name and address of manufacturer's authorised representative (if any) : ZIPPER MASCHINEN GMBH  
 Gewerbepark 84707 Schluslberg Austria
- 1.5. Name(s) and address(es) of assembly/manufacture plant(s) : The same as 1.3
- 1.6. ~~Engine type designation/~~ engine family designation/ ~~ET~~ : Engine family name: KD15  
 Parent engine: KD195FC-1  
 Engine within family: KD195FC, KD192FC, KD192FC-1, KD188FC, KD188FC-1, KD186FC, KD186FC-1
- 1.7. Category and sub-category of the engine type/engine family : Category: NRE  
 Sub-category: NRE-v-1
- 1.8. Emissions durability period category : N/A
- 1.9. Emissions stage : V/~~Special Purpose Engine (SPE)~~
- 1.10. In case of NRS <19 kW only, engine family consisting exclusively of engine types for snow throwers : ~~Yes~~/No
- 1.11. Reference power is : ~~rated net power~~/maximum net power
- 1.12. Primary NRSC test cycle : ~~C1/C2/D2/E2/E3/F/G1/G2/G3/H~~
- 1.12.1. In case of variable speed IWP category only, Additional propulsion test cycle : Not applicable/~~E2/E3~~
- 1.12.2. In case of IWP category only, additional auxiliary NRSC test cycle : Not applicable/~~D2/C4~~
- 1.13. Transient test cycle : Not applicable/~~NRTC/LSI-NRTC~~
- 1.14. Restrictions on use (if applicable) : N/A



**Part B**

**2. COMMON DESIGN PARAMETERS OF ENGINE FAMILY<sup>(1)</sup>**

2.1.	Combustion Cycle	:	four stroke cycle/ <del>two-stroke cycle/rotary/other (specify)</del>
2.2.	Ignition Type	:	Compression ignition/ <del>spark ignition</del>
2.3.	<b>Configuration of the cylinders</b>		
2.3.1.	Position of the cylinders in the block	:	Single/ <del>in-line/ opposed/ radial/ other(specify)</del>
2.3.2.	Bore centre to centre dimension (mm)	:	N/A
2.4.	<b>Combustion chamber type/design</b>		
2.4.1.	Open chamber/divided chamber/ other(specify)	:	Open chamber
2.4.2.	Valve and porting configuration	:	Refer to drawing No. 002
2.4.3.	Number of valves per cylinder	:	One in and one out
2.5.	Range of individual cylinder displacement (cm <sup>3</sup> )	:	See item 3.6.4. in Part C
2.6.	Main Cooling medium	:	Air/ <del>Water/Oil</del>
2.7.	Method of air aspiration	:	naturally aspirated/ <del>pressure charged/pressure charged with charge cooler</del>
2.8.	<b>Fuel</b>		
2.8.1.	Fuel Type	:	Diesel (non-road gas-oil)/ <del>Ethanol for dedicated compression ignition engines (E10)/Ethanol (E85)/Natural gas/Biomethane/Liquid Petroleum Gas (LPG)</del>
2.8.1.1.	Sub Fuel type (Natural gas/Biomethane only)	:	<del>Universal fuel – high calorific fuel (H-gas) and low calorific fuel (L-gas)/Restricted fuel – high calorific fuel (H-gas)/Restricted fuel – low calorific fuel (L-gas)/Fuel specific (LNG)</del>
2.8.2.	Fuelling arrangement	:	Liquid-fuel only/ <del>Gaseous-fuel only/Dual-fuel type 1A/Dual-fuel type 1B/Dual-fuel type 2A/Dual-fuel type 2B/Dual-fuel type 3B</del>
2.8.3.	List of additional fuels compatible with use by the engine declared by the manufacturer in accordance with point 1.4. of Annex I to Commission Delegated Regulation 2018/989 on technical and general requirements (provide reference to recognised standard or specification)	:	N/A
2.8.4.	Lubricant added to fuel	:	Yes/No
2.8.4.1.	Specification	:	N/A
2.8.4.2.	Ratio of fuel to oil	:	N/A
2.8.5.	Fuel supply type	:	Pump (high pressure) line and injector/ <del>in-line pump or distributor pump/Unit injector/Common rail/Carburettor/port injector/direct injector/Mixing unit/other(specify)</del> :



2.9.	Engine management systems	:	mechanical/ <del>electronic control</del> strategy <sup>(2)</sup>
2.10.	<b>Miscellaneous devices</b>		
2.10.1.	Exhaust gas recirculation (if yes, complete section 3.10.1. and provide a schematic diagram of the location and order of the devices)	:	No
2.10.2.	Water injection (if yes, complete section 3.10.2.and provide a schematic diagram of the location and order of the devices)	:	No
2.10.3.	Air injection (if yes, complete section 3.10.2.and provide a schematic diagram of the location and order of the devices)	:	No
2.10.4.	Others (if yes, complete section 3.10.4 and provide a schematic diagram of the location and order of the devices)	:	No
2.11.	<b>Exhaust after-treatment system</b> (if yes provide a schematic diagram of the location and order of the devices)	:	<b>Yes/No</b>
2.11.1.	Oxidation catalyst (if yes, complete section 3.11.2.)	:	Yes
2.11.2.	DeNO <sub>x</sub> system with selective reduction of NO <sub>x</sub> (addition of reducing agent) (if yes, complete section 3.11.3.)	:	No
2.11.3.	Other DeNO <sub>x</sub> systems (if yes, complete section 3.11.3.)	:	No
2.11.4.	Three-way catalyst combining oxidation and NO <sub>x</sub> reduction (if yes, complete section 3.11.3.)	:	No
2.11.5.	Particulate trap with passive regeneration (if yes, complete section 3.11.4.)	:	No
2.11.5.1	Wall-flow/non-wall-flow	:	No
2.11.6.	Particulate trap with active regeneration (if yes, complete section 3.11.4.)	:	No
2.11.6.1	Wall-flow/non-wall-flow	:	No
2.11.7.	Other particulate traps (if yes, complete section 3.11.4.)	:	No
2.11.8.	Other after-treatment devices(specify) (if yes, complete section 3.11.5.)	:	No
2.11.9.	Other devices or features that have a strong influence on emissions (if yes, complete section 3.11.7.)	:	No



**Part C**

**3. ESSENTIAL CHARACTERISTICS OF THE ENGINE TYPE(S)**

Item Number	Item Description	Test	Installation	Homologation	Parent engine	Engine types within the engine family (if applicable)							
					Type 1	Type 2	Type 3	Type 4	Type 5	Type 6	Type 7	Type 8	
<b>3.1</b>	<b>Engine Identification</b>												
3.1.1.	Engine type designation			X	KD195FC-1	KD195FC	KD192FC	KD192F C-1	KD188FC	KD188F C-1	KD186FC	KD186F C-1	
3.1.2.	Engine type designation shown on engine marking:			X	Yes	←	←	←	←	←	←	←	
3.1.3.	Location of the statutory marking:			X	Refer to drawing No. 001	←	←	←	←	←	←	←	
3.1.4.	Method of attachment of the statutory marking:			X	By engraving and/or labelling	←	←	←	←	←	←	←	
3.1.5.	Drawings of the location of the engine identification number (complete example with dimensions):			X	Refer to drawing No. 001	←	←	←	←	←	←	←	
<b>3.2.</b>	<b>Performance Parameters</b>												
3.2.1.	Declared rated speed (rpm):	X			3000	3600	3600	3000	3600	3000	3600	3000	

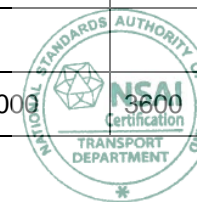

Item Number	Item Description	Test	Installation	Homologation	Parent engine	Engine types within the engine family (if applicable)							
					Type 1	Type 2	Type 3	Type 4	Type 5	Type 6	Type 7	Type 8	
3.2.1.1.	Fuel delivery/stroke (mm <sup>3</sup> ) for diesel engine, <del>fuel flow (g/h) for other engines,</del> at rated net power:			X	26.9	25.5	24.2	25.1	21.6	22.9	21.5	20.4	
3.2.1.2.	Declared rated net power (kW):	X			7.5	7.9	7.5	7.0	6.7	6.4	6.6	5.7	
3.2.2.	Maximum power speed(rpm):			X	Same as above 3.2.1.	←	←	←	←	←	←	←	
3.2.2.1.	Fuel delivery/stroke (mm <sup>3</sup> ) for diesel engine, <del>fuel flow (g/h) for other engines,</del> at maximum net power			X	Same as above 3.2.1.1.	←	←	←	←	←	←	←	
3.2.2.2.	Maximum net power (kW):	X		X	Same as above 3.2.1.2.	←	←	←	←	←	←	←	
3.2.3.	Declared maximum torque speed (rpm):	X			2250	2700	2700	2250	2700	2250	2700	2250	
3.2.3.1.	Fuel delivery/stroke (mm <sup>3</sup> ) for diesel engine, <del>fuel flow (g/h) for other engines,</del> at maximum torque speed:			X	29.6	28	26.6	27.6	23.8	25.2	23.7	22.4	
3.2.3.2.	Declared maximum torque (Nm):	X			27.5	24.1	22.9	25.6	20.4	23.4	20.1	20.9	
3.2.4.	Declared 100% test speed:	X			3000	3600	3600	3000	3600	3000	3600	3000	
3.2.5.	Declared Intermediate test speed:	X			N/A	←	←	←	←	←	←	←	

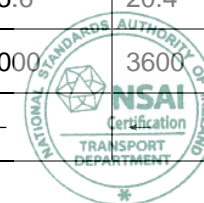

Item Number	Item Description	Test	Installation	Homologation	Parent engine	Engine types within the engine family (if applicable)							
						Type 1	Type 2	Type 3	Type 4	Type 5	Type 6	Type 7	Type 8
3.2.6.	Idle speed (rpm)	X			1300	←	←	←	←	←	←	←	
3.2.7.	Maximum no load speed (rpm):	X			3300	3850	3850	3300	3850	3300	3850	3300	
3.2.8.	Declared minimum torque (Nm)	X			N/A	←	←	←	←	←	←	←	
<b>3.3.</b>	<b>Run-in procedure</b>												
3.3.1.	Run in time:	X			8h	←	←	←	←	←	←	←	
3.3.2.	Run-in cycle:	X			G2	←	←	←	←	←	←	←	
<b>3.4.</b>	<b>Engine test</b>												
3.4.1.	Specific fixture required: Yes/No	X			No	←	←	←	←	←	←	←	
3.4.1.1.	Description, including photographs and/or drawings, of the system for mounting the engine on the test bench including the power transmission shaft for connection to the dynamometer:	X			N/A	←	←	←	←	←	←	←	
3.4.2.	Exhaust mixing chamber permitted by manufacturer: Yes/No	X			No	←	←	←	←	←	←	←	
3.4.2.1.	exhaust mixing chamber description, photograph and/or drawing:	X			N/A	←	←	←	←	←	←	←	



Item Number	Item Description	Test	Installation	Homologation	Parent engine	Engine types within the engine family (if applicable)							
						Type 1	Type 2	Type 3	Type 4	Type 5	Type 6	Type 7	Type 8
3.4.3.	Manufacturers chosen NRSC: RMC/ Discrete mode	X			Discrete mode	←	←	←	←	←	←	←	←
3.4.4.	Additional NRSC: E2/D2/C1	X			N/A	←	←	←	←	←	←	←	←
3.4.5.	Number of pre-conditioning cycles prior to transient test	X			N/A	←	←	←	←	←	←	←	←
3.4.6.	Pre-conditioning for RMC NRSC: Steady-state operation/RMC	X			N/A	←	←	←	←	←	←	←	←
3.4.6.1.	In case of RMC, number of pre-conditioning RMC prior to RMC NRSC test	X			N/A	←	←	←	←	←	←	←	←
<b>3.5.</b>	<b>Lubrication system</b>												
3.5.1.	<i>Lubricant temperature</i>												
3.5.1.1.	Minimum (deg. °C):	X			70	←	←	←	←	←	←	←	←
3.5.1.2.	Maximum (deg. °C):	X			120	←	←	←	←	←	←	←	←
<b>3.6.</b>	<b>Combustion Cylinder</b>												
3.6.1.	Bore(mm):			X	95	95	92	92	88	88	86	86	
3.6.2.	Stroke(mm):			X	75	75	75	75	75	75	72	72	

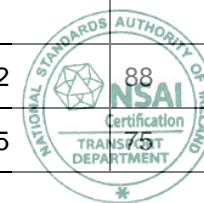

Item Number	Item Description	Test	Installation	Homologation	Parent engine	Engine types within the engine family (if applicable)							
					Type 1	Type 2	Type 3	Type 4	Type 5	Type 6	Type 7	Type 8	
3.6.3.	Number of cylinders:			X	1	←	←	←	←	←	←	←	
3.6.4.	Engine total swept volume (cm <sup>3</sup> ):			X	532	532	499	499	456	456	418	418	
3.6.5.	Swept volume per cylinder as % of parent engine:			X	100%	100%	93.8%	93.8%	85.7%	85.7%	78.5%	78.5%	
3.6.6.	Volumetric compression ratio:			X	20:1	20:1	20:1	20:1	20:1	20:1	19.5:1	19.5:1	
3.6.7.	Combustion system description:			X	Compression ignition	←	←	←	←	←	←	←	
3.6.8.	Drawings of combustion chamber and piston crown:			X	Refer to drawing no. 002	←	←	←	←	←	←	←	
3.6.9.	Minimum cross sectional area of inlet and outlet ports (mm <sup>2</sup> ):			X	Inlet 1093 Outlet 908	Inlet 1093 Outlet 908	Inlet 1093 Outlet 908	Inlet 1093 Outlet 908	Inlet 990 Outlet 750	Inlet 990 Outlet 750	Inlet 854.9 Outlet 551.3	Inlet 854.9 Outlet 551.3	
3.6.10.	<i>Valve timing</i>												
3.6.10.1.	Maximum lift and angles of opening and closing in relation to dead centre or equivalent data:			X	Refer to drawing No. 005	←	←	←	←	←	←	←	
3.6.10.2.	Reference and/or setting range:			X	TDC	←	←	←	←	←	←	←	

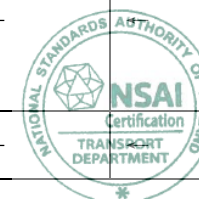

Item Number	Item Description	Test	Installation	Homologation	Parent engine	Engine types within the engine family (if applicable)							
						Type 1	Type 2	Type 3	Type 4	Type 5	Type 6	Type 7	Type 8
3.6.10.3.	Variable valve timing system: Yes/No			X	No	←	←	←	←	←	←	←	←
3.6.10.3.1.	Type: continuous/(on/off)			X	N/A	←	←	←	←	←	←	←	←
3.6.10.3.2.	Cam phase shift angle:			X	N/A	←	←	←	←	←	←	←	←
3.6.11.	Porting configuration												
3.6.11.1.	position, size and number:			X	Refer to drawing No. 002	←	←	←	←	←	←	←	←
<b>3.7.</b>	<b>Cooling system</b>												
3.7.1.	<i>Liquid cooling</i>				N/A	←	←	←	←	←	←	←	←
3.7.1.1.	Nature of liquid:			X	No	←	←	←	←	←	←	←	←
3.7.1.2.	Circulating pumps: Yes/No			X	N/A	←	←	←	←	←	←	←	←
3.7.1.2.1.	type(s):			X	N/A	←	←	←	←	←	←	←	←
3.7.1.2.2.	Drive ratio(s):			X	N/A	←	←	←	←	←	←	←	←
3.7.1.3.	Minimum coolant temperature at outlet (deg. °C):	X			N/A	←	←	←	←	←	←	←	←

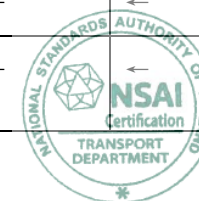

Item Number	Item Description	Test	Installation	Homologation	Parent engine	Engine types within the engine family (if applicable)							
						Type 1	Type 2	Type 3	Type 4	Type 5	Type 6	Type 7	Type 8
3.7.1.4.	Maximum coolant temperature at outlet (deg. °C):	X			N/A	←	←	←	←	←	←	←	←
3.7.2.	<i>Air cooling</i>												
3.7.2.1.	fan: Yes/No			X	Yes	←	←	←	←	←	←	←	←
3.7.2.1.0.	Make:			X	KOOP POWER	←	←	←	←	←	←	←	←
3.7.2.1.1.	type(s):			X	195	195	192	192	188	188	186	186	
3.7.2.1.2.	Drive ratio(s):			X	1:1	←	←	←	←	←	←	←	←
3.7.2.2.	Maximum temperature at reference point (deg. °C):			X	500	←	←	←	←	←	←	←	←
3.7.2.2.1.	Reference point location			X	Exhaust pipe	←	←	←	←	←	←	←	←
<b>3.8.</b>	<b>Aspiration</b>												
3.8.1.	Maximum allowable intake depression at 100% engine speed and at 100% load (kPa)	X	X		-1.5	←	←	←	←	←	←	←	←
3.8.1.1.	With clean air cleaner:	X	X		-0.2	←	←	←	←	←	←	←	←
3.8.1.2.	With dirty air cleaner:	X	X		-1.3	←	←	←	←	←	←	←	←



Item Number	Item Description	Test	Installation	Homologation	Parent engine	Engine types within the engine family (if applicable)							
					Type 1	Type 2	Type 3	Type 4	Type 5	Type 6	Type 7	Type 8	
3.8.1.3.	Location, of measurement:	X	X		Behind air filter	←	←	←	←	←	←	←	←
3.8.2.	Pressure charger(s): Yes/No			X	No	←	←	←	←	←	←	←	←
3.8.2.0.	Make:			X	N/A	←	←	←	←	←	←	←	←
3.8.2.1.	Type(s):			X	N/A	←	←	←	←	←	←	←	←
3.8.2.2.	Description and schematic diagram of the system (e.g. maximum charge pressure, waste gate, VGT, Twin turbo, etc.):			X	N/A	←	←	←	←	←	←	←	←
3.8.3.	Charge air cooler: Yes/No	X	X		No	←	←	←	←	←	←	←	←
3.8.3.1.	Type: air-air/air-water/other(specify)		X		N/A	←	←	←	←	←	←	←	←
3.8.3.2.	Maximum charge air cooler outlet temperature at 100% speed and 100% load (deg. °C):	X	X		N/A	←	←	←	←	←	←	←	←
3.8.3.3.	Maximum allowable pressure drop across charge cooler at 100% engine speed and at 100% load (kPa):	X	X		N/A	←	←	←	←	←	←	←	←
3.8.4.	Intake throttle valve: Yes/No			X	No	←	←	←	←	←	←	←	←
3.8.5.	Device for recycling crankcase gases: Yes/No			X	Yes	←	←	←	←	←	←	←	←

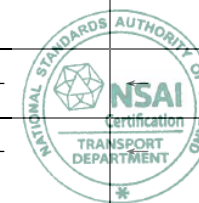

Item Number	Item Description	Test	Installation	Homologation	Parent engine	Engine types within the engine family (if applicable)							
						Type 1	Type 2	Type 3	Type 4	Type 5	Type 6	Type 7	Type 8
3.8.5.1.	If yes, description and drawings:			X	Refer to drawing No. 006	←	←	←	←	←	←	←	←
3.8.5.2.	If no, compliance with paragraph 6.10 of Annex VI to Delegated Regulation (EU) 2017/654: Yes/No	X			N/A	←	←	←	←	←	←	←	←
3.8.6.	Inlet path												
3.8.6.1.	Description of inlet path, (with drawings, photographs and/or part numbers):			X	Refer to drawing No. 007	←	←	←	←	←	←	←	←
3.8.7.	Air filter			X	Yes	←	←	←	←	←	←	←	←
3.8.7.0.	Make:			X	CHANG ZHOU GONG CHUANG	←	←	←	←	←	←	←	←
3.8.7.1.	Type:			X	KD195F	KD195F	KD192F	KD192F	KD188F	KD188F	KD186F	KD186F	
3.8.8.	Intake air-silencer				N/A	←	←	←	←	←	←	←	←
3.8.1.0.	Make:			X	N/A	←	←	←	←	←	←	←	←
3.8.1.1.	Type:			X	N/A	←	←	←	←	←	←	←	←
3.9.	<b>Exhaust system</b>												

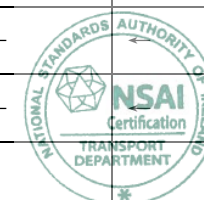

Item Number	Item Description	Test	Installation	Homologation	Parent engine	Engine types within the engine family (if applicable)							
						Type 1	Type 2	Type 3	Type 4	Type 5	Type 6	Type 7	Type 8
3.9.1.	Description of the exhaust system (with drawings, photos and/or part numbers as required):			X	Refer to drawing No. 008	←	←	←	←	←	←	←	←
3.9.2.	Maximum exhaust temperature (deg. °C):	X			500	←	←	←	←	←	←	←	←
3.9.3.	Maximum permissible exhaust backpressure at 100% engine speed and at 100% load (kPa):	X	X		0.5	←	←	←	←	←	←	←	←
3.9.3.1.	Location of measurement:	X	X		outlet of muffler	←	←	←	←	←	←	←	←
3.9.4.	Exhaust backpressure at loading level specified by manufacturer for variable restriction after-treatment at start of test (kPa):	X			N/A	←	←	←	←	←	←	←	←
3.9.4.1.	Location and speed/load conditions:	X			N/A	←	←	←	←	←	←	←	←
3.9.5.	Exhaust throttle valve: Yes/No			X	No	←	←	←	←	←	←	←	←
<b>3.10.</b>	<b>Miscellaneous devices: Yes/No</b>				No	←	←	←	←	←	←	←	←
3.10.1.	<i>Exhaust gas recirculation (EGR)</i>				N/A	←	←	←	←	←	←	←	←
3.10.1.1.	Characteristics: cooled/uncooled, high pressure/low pressure/other (specify):			X	N/A	←	←	←	←	←	←	←	←

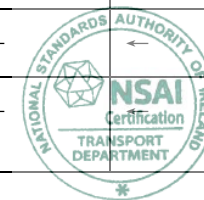

Item Number	Item Description	Test	Installation	Homologation	Parent engine	Engine types within the engine family (if applicable)							
						Type 1	Type 2	Type 3	Type 4	Type 5	Type 6	Type 7	Type 8
3.10.2.	<i>Water injection</i>				N/A	←	←	←	←	←	←	←	←
3.10.2.1.	Operation principle:			X	N/A	←	←	←	←	←	←	←	←
3.10.3.	<i>Air injection</i>				N/A	←	←	←	←	←	←	←	←
3.10.3.1.	Operation principle:			X	N/A	←	←	←	←	←	←	←	←
3.10.4.	Other(s)				N/A	←	←	←	←	←	←	←	←
3.10.4.1.	Type(s):			X	N/A	←	←	←	←	←	←	←	←
<b>3.11.</b>	<b>Exhaust after-treatment system</b>												
3.11.1.	<i>Location</i>		X		MUFFLER	←	←	←	←	←	←	←	←
3.11.1.1.	Place(s) and maximum/minimum distance(s) from engine to first after-treatment device:		X		Max:220 mm Min:150 mm	←	←	←	←	←	←	←	←
3.11.1.2.	Maximum temperature drop from exhaust or turbine outlet to first after-treatment device (deg. °C) if stated:	X	X		N/A	←	←	←	←	←	←	←	←
3.11.1.2.1.	Test conditions for measurement:	X	X		N/A	←	←	←	←	←	←	←	←
3.11.1.3.	Minimum temperature at inlet to first after-treatment device (deg. C), if stated:	X	X		250	←	←	←	←	←	←	←	←

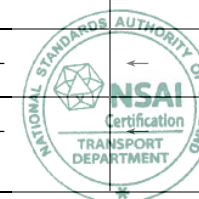

Item Number	Item Description	Test	Installation	Homologation	Parent engine	Engine types within the engine family (if applicable)							
					Type 1	Type 2	Type 3	Type 4	Type 5	Type 6	Type 7	Type 8	
3.11.1.3.1.	Test conditions for measurement:	X	X		N/A	←	←	←	←	←	←	←	←
3.11.2.	Oxidation catalyst												
3.11.2.0.	Make and type				Depurate/ DP79316	←	←	←	←	←	←	←	←
3.11.2.1.	Number of catalytic converters and elements:			X	1	←	←	←	←	←	←	←	←
3.11.2.2.	Dimensions and volume of the catalytic converter(s):			X	Φ77*80 372.34mm <sup>3</sup>	←	←	←	←	←	←	←	←
3.11.2.3.	Total charge of precious metals:			X	Pt: 197.24mg	←	←	←	←	←	←	←	←
3.11.2.4.	Relative concentration of each compound:			X	Pt: Pd: Rh=197 .21:0:0	←	←	←	←	←	←	←	←
3.11.2.5.	Substrate (structure and material):			X	Cellular, 0Cr2 1A16	←	←	←	←	←	←	←	←
3.11.2.6.	Cell density:			X	300cps	←	←	←	←	←	←	←	←
3.11.2.7.	Type of casing for the catalytic converter(s):			X	Column	←	←	←	←	←	←	←	←
3.11.3.	<i>Catalytic exhaust gas after treatment system for NO<sub>x</sub> or three way catalyst</i>				N/A	←	←	←	←	←	←	←	←

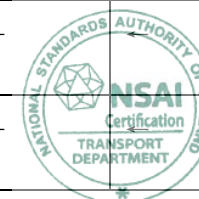

Item Number	Item Description	Test	Installation	Homologation	Parent engine	Engine types within the engine family (if applicable)							
					Type 1	Type 2	Type 3	Type 4	Type 5	Type 6	Type 7	Type 8	
3.11.4.	Particulate trap				N/A	←	←	←	←	←	←	←	←
3.11.5.	Other systems				N/A	←	←	←	←	←	←	←	←
3.11.6.	Infrequent Regeneration				N/A	←	←	←	←	←	←	←	←
3.11.7.	Other device(s) or feature(s)				N/A	←	←	←	←	←	←	←	←
<b>3.12.</b>	<b>Fuel feed for liquid-fuelled CI or, where applicable, dual-fuel engines</b>												
3.12.1.	Feed pump												
3.12.1.1.	Pressure (kPa) or characteristic diagram:			X	N/A	←	←	←	←	←	←	←	←
3.12.2.	Injection system												
3.12.2.1.	Pump				KD192FC	KD192FC	KD192FC	KD192FC	KD188FC	KD188FC	KD186FC	KD186FC	KD186FC
3.12.2.1.0.	Make:			X	NANJING WEIFU	←	←	←	←	←	←	←	←
3.12.2.1.1.	Type(s):			X	SINGLE PUMP	←	←	←	←	←	←	←	←
3.12.2.1.2.	Rated pump speed (rpm):			X	N/A	←	←	←	←	←	←	←	←

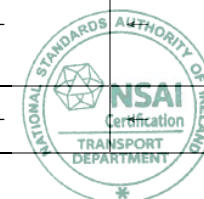

Item Number	Item Description	Test	Installation	Homologation	Parent engine	Engine types within the engine family (if applicable)							
						Type 1	Type 2	Type 3	Type 4	Type 5	Type 6	Type 7	Type 8
3.12.2.1.3.	mm <sup>3</sup> per stroke or cycle at full injection at rated pump speed:			X	N/A	←	←	←	←	←	←	←	←
3.12.2.1.4.	Torque peak pump speed (rpm):			X	N/A	←	←	←	←	←	←	←	←
3.12.2.1.5.	mm <sup>3</sup> per stroke or cycle at full injection at torque peak pump speed			X	N/A	←	←	←	←	←	←	←	←
3.12.2.1.6.	Characteristic diagram:			X	N/A	←	←	←	←	←	←	←	←
3.12.2.1.7.	Method used: on engine/on pump bench			X	on engine	←	←	←	←	←	←	←	←
3.12.2.2.	Injection timing				N/A	←	←	←	←	←	←	←	←
3.12.2.2.1.	Injection timing curve:			X	N/A	←	←	←	←	←	←	←	←
3.12.2.2.2.	Static Timing:			X	BTDC 15±1	←	←	←	←	←	←	←	←
3.12.2.3.	Injection piping												
3.12.2.3.1.	Length(s) (mm):			X	480	←	←	←	←	←	←	←	←
3.12.2.3.2.	Internal diameter (mm):			X	1.5	←	←	←	←	←	←	←	←
3.12.2.4.	Common rail: Yes/No			X	No	←	←	←	←	←	←	←	←
3.12.2.4.0.	Make:			X	N/A	←	←	←	←	←	←	←	←

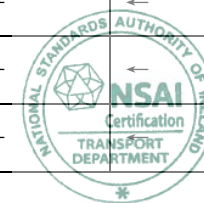

Item Number	Item Description	Test	Installation	Homologation	Parent engine	Engine types within the engine family (if applicable)							
						Type 1	Type 2	Type 3	Type 4	Type 5	Type 6	Type 7	Type 8
3.12.2.4.1.	Type:			X	N/A	←	←	←	←	←	←	←	←
3.12.3.	Injector(s)												
3.12.2.0.	Make:			X	NANJING WEIFU	←	←	←	←	←	←	←	←
3.12.3.1.	Type(s):			X	P	←	←	←	←	←	←	←	←
3.12.3.2.	Opening pressure (kPa):			X	21000±1000	←	←	←	←	←	←	←	←
3.12.4.	Electronic control unit (ECU): Yes/No			X	No	←	←	←	←	←	←	←	←
3.12.4.0.	Make:			X	N/A	←	←	←	←	←	←	←	←
3.12.4.1.	Type(s):			X	N/A	←	←	←	←	←	←	←	←
3.12.4.2.	Software calibration number(s):			X	N/A	←	←	←	←	←	←	←	←
3.12.4.3.	Communication standard(s) for access to data stream information: ISO 27145 with ISO 15765-4 (CAN-based)/ISO 27145 with ISO 13400 (TCP/IP-based)/SAE J1939-73	X		X	N/A	←	←	←	←	←	←	←	←
3.12.5.	Governor												

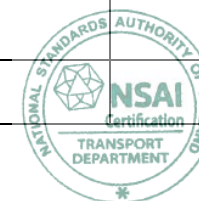

Item Number	Item Description	Test	Installation	Homologation	Parent engine	Engine types within the engine family (if applicable)							
						Type 1	Type 2	Type 3	Type 4	Type 5	Type 6	Type 7	Type 8
3.12.5.0.	Make:			X	Chang zhou Changhuai	←	←	←	←	←	←	←	←
3.12.5.1.	Type(s):			X	Mechanical	←	←	←	←	←	←	←	←
3.12.5.2.	Speed at which cut-off starts under full load:			X	N/A	←	←	←	←	←	←	←	←
3.12.5.3.	Maximum no-load speed:			X	3300	3850	3850	3300	3850	3300	3850	3300	3300
3.12.5.4.	Idle speed:			X	1300	←	←	←	←	←	←	←	←
3.12.6.	<i>Cold-start system: Yes/No</i>			X	No	←	←	←	←	←	←	←	←
3.12.6.0.	Make:			X	N/A	←	←	←	←	←	←	←	←
3.12.6.1.	Type(s):			X	N/A	←	←	←	←	←	←	←	←
3.12.6.2.	Description:			X	N/A	←	←	←	←	←	←	←	←
3.12.7.	Fuel temperature at the inlet to the fuel injection pump				N/A	←	←	←	←	←	←	←	←
3.12.7.1.	Minimum (deg. °C):	X			-5	←	←	←	←	←	←	←	←
3.12.7.2.	Maximum (deg. °C):	X			30	←	←	←	←	←	←	←	←

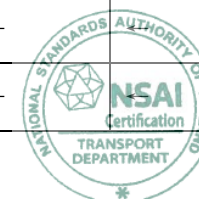

Item Number	Item Description	Test	Installation	Homologation	Parent engine	Engine types within the engine family (if applicable)							
					Type 1	Type 2	Type 3	Type 4	Type 5	Type 6	Type 7	Type 8	
3.13.	Fuel feed for liquid fuel spark ignition engine				N/A	←	←	←	←	←	←	←	
3.14.	Fuel feed for gaseous fuel engines or where applicable, dual fuel engines (in the case of systems laid out in a different manner, supply equivalent information)				N/A	←	←	←	←	←	←	←	
3.15.	Ignition system				N/A	←	←	←	←	←	←	←	



KD195FC-1/ KD195FC/ KD192FC/ KD192FC-1



KD186FC/ KD186FC-1/ KD188FC/ KD188FC-1



ENGINE TYPE	KD195FC-1, KD195FC, KD192FC, KD192FC-1, KD188FC, KD188FC-1, KD186FC, KD186FC-1
PHOTOGRAPHS OF THE ENGINES	
DRAWING NO.	00A



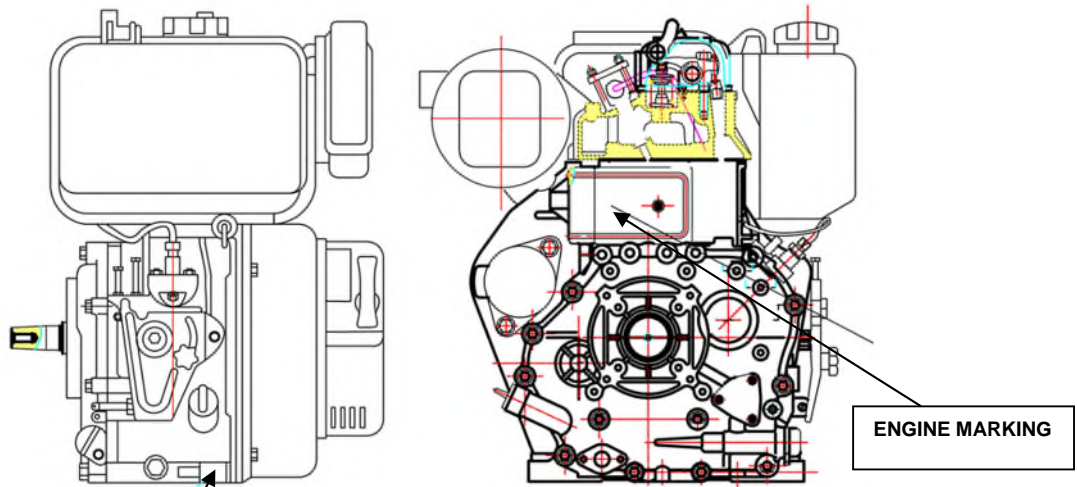

ENGINE S/N (engine production date inc.)

**Changzhou Koop Power Machinery Co., Ltd.**

ENGINE TYPE: KD195FC-1      ENGINE FAMILY: KD15  
 RATED POWER: 7.5KW      RATED SPEED: 3000rpm

Approval No./Approval mark:  
 e24\*2016/1628\*XXXXXXXX\*XXXX\*00

Add: NO.6 Hexiang Road, Wujin Economic Development Zone,  
 Changzhou City, Jiangsu Province China.

Remarks:

1. All the information in following rectangular area are included on the engine marking.
2. This sample only shows the contents that need to be included on the engine marking, the actual layout may adjust according manufacturer's requirement.

Trade name/Trade mark/Manufacturer name/address  
 Engine model  
 Engine identification number (engine production date inc.)  
 Approval No./Approval mark:

ENGINE TYPE	KD195FC-1
POSITION OF STATUTORY MARKING AND ENGINE IDENTIFICATION NUMBER	
DRAWING NO.	001



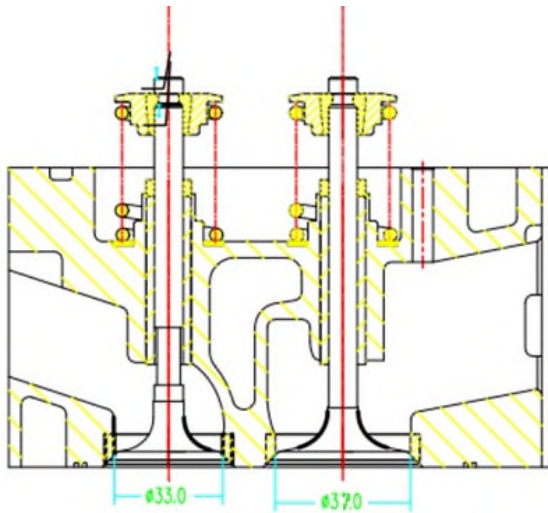

KD195FC-1/KD195FC/KD192FC/KD192FC-1

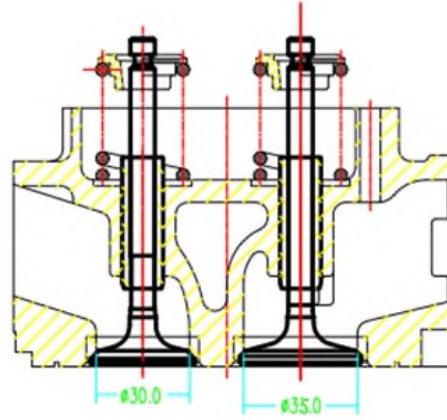

KD188FC/KD188FC-1

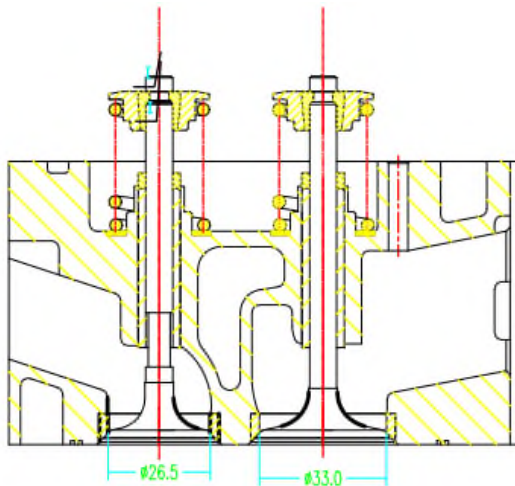

KD186FC/KD186FC-1

Part No./Factory internal Drawing No.: KD195FC-02100/ KD192FC-02100/KD188FC-02100/KD186FC-02100

ENGINE TYPE	KD195FC-1, KD195FC, KD192FC, KD192FC-1, KD188FC, KD188FC-1, KD186FC, KD186FC-1
COMBUSTION CHAMBER, VALVE AND PORT CONFIGURATION	
DRAWING NO.	002

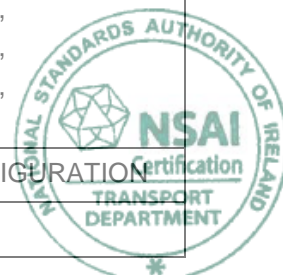

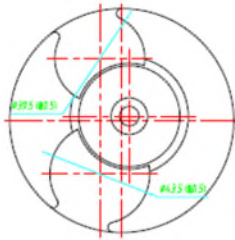
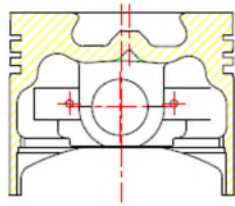

KD195FC-1/KD195FC

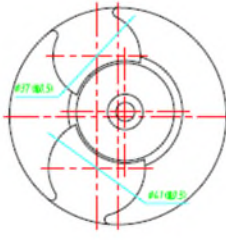
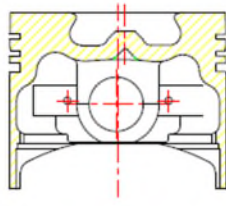

KD192FC/KD192FC-1

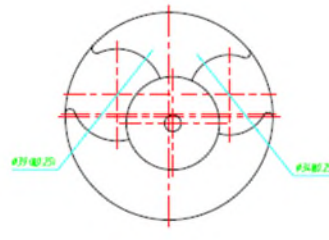
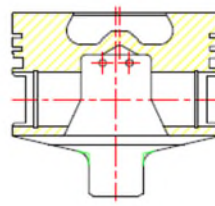

KD188FC/KD188FC-1

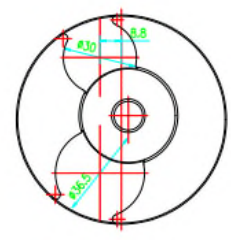
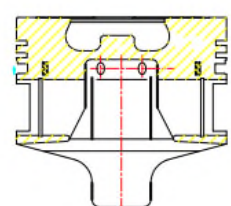

D186FC/KD186FC-1

Part No./Factory internal Drawing No.: KD195FC-04005/KD192FC-04005/ KD188FC-04005/ KD186FC-04005

ENGINE TYPE	KD195FC-1,KD195FC, KD192FC,KD192FC-1, KD188FC,KD188FC-1, KD186FC,KD186FC-1
PISTON	
DRAWING NO.	003



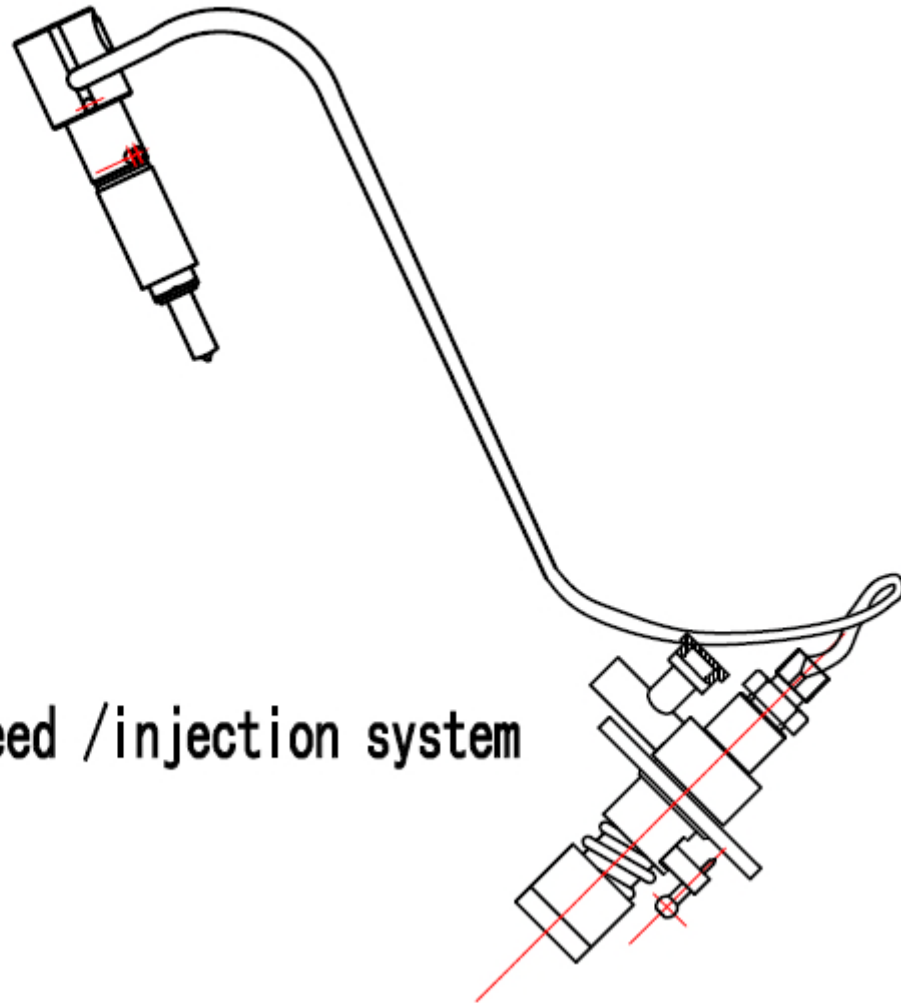

**fuel feed /injection system**

Part No./Factory internal Drawing No.:KD192FC-10100/ KD188FC-10100/ KD186FC-10100

ENGINE TYPE	KD195FC-1,KD195FC, KD192FC,KD192FC-1, KD188FC,KD188FC-1, KD186FC,KD186FC-1
FUEL FEED/ INJECTION SYSTEM	
DRAWING NO.	004



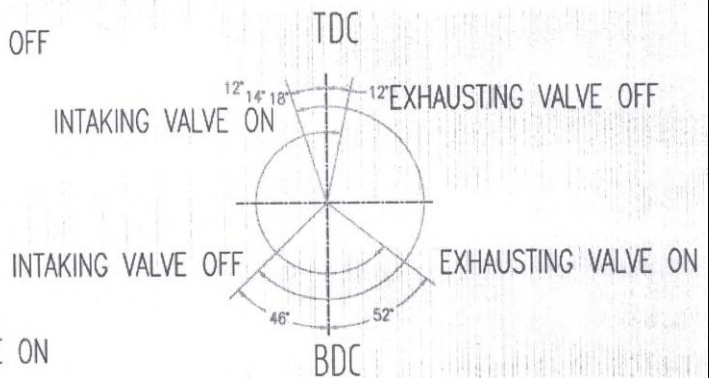
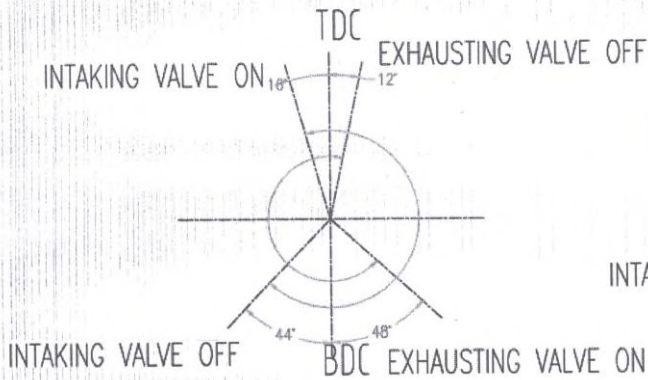

KD195FC-1/ KD195FC// KD192FC/KD192FC-1

KD186FC/KD186FC-1/KD188FC/KD188FC-1

ENGINE TYPE	KD195FC-1, KD195FC, KD192FC, KD192FC-1, KD188FC, KD188FC-1, KD186FC, KD186FC-1
VALVE TIMING	
DRAWING NO.	005



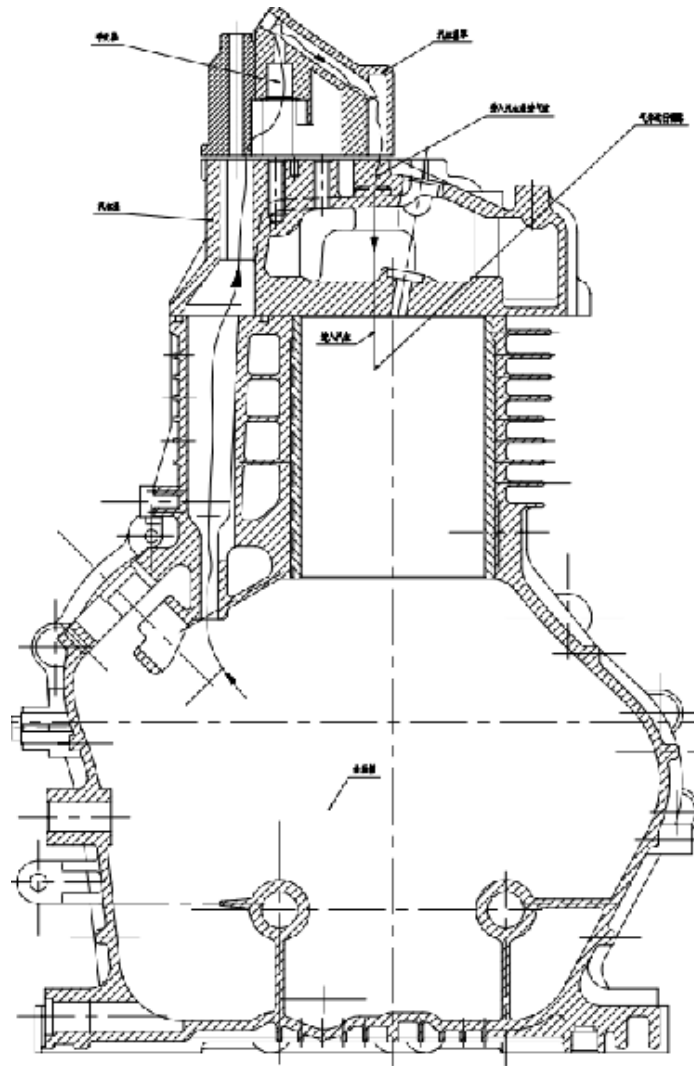

The exhaust gas discharged from the crankcase enters the cylinder head through the body port and the cylinder head port, then enters the intake pipe through the cylinder head cover check valve structure, and then enters the combustion chamber.

ENGINE TYPE	KD195FC-1,KD195FC, KD192FC,KD192FC-1, KD188FC,KD188FC-1, KD186FC,KD186FC-1
DEVICE FOR RECYCLING CRANKCASE GASES	
DRAWING NO.	006



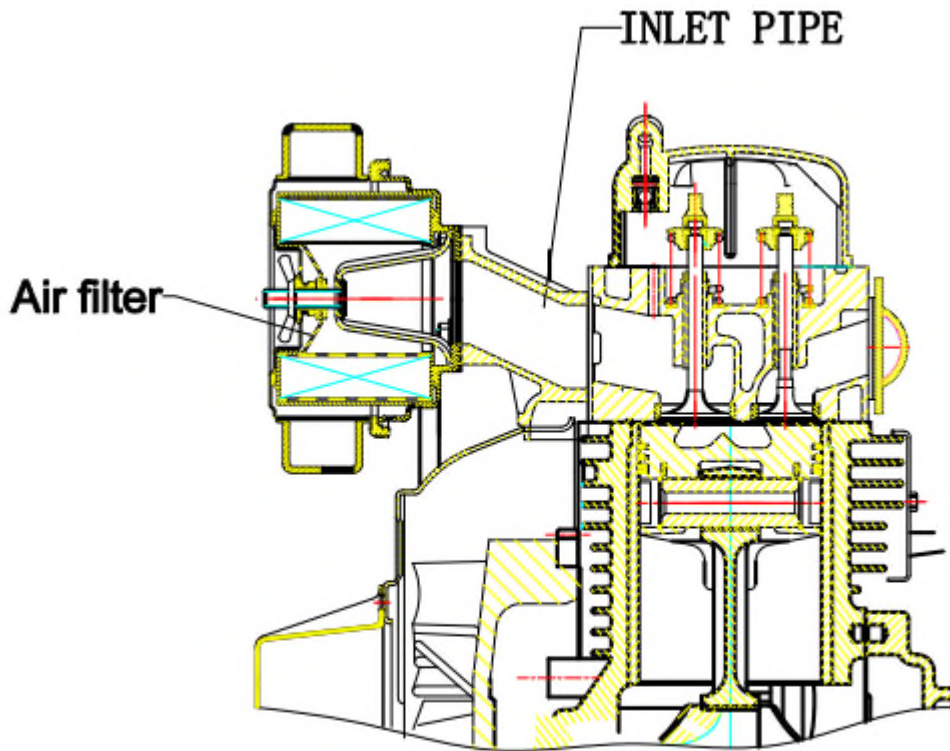

ENGINE TYPE	KD195FC-1, KD195FC, KD192FC, KD192FC-1, KD188FC, KD188FC-1, KD186FC, KD186FC-1
INLET PATH	
DRAWING NO.	007



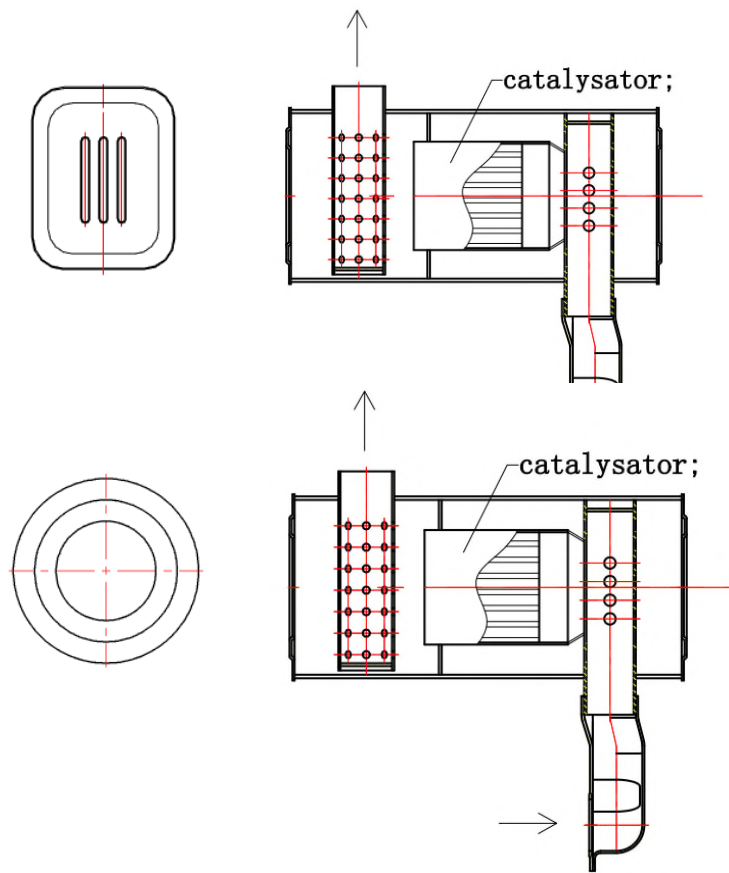

Part No./Factory internal Drawing No.: KD195FC-08000/KD195FC-08000A/KD192FC-08000/KD192FC-08000A/ KD188FC-08000/KD188FC-08000A/KD186FC-08000/ KD186FC-08000A

ENGINE TYPE	KD195FC-1,KD195FC, KD192FC,KD192FC-1, KD188FC,KD188FC-1, KD186FC,KD186FC-1
EXHAUST SYSTEM	
DRAWING NO.	008



技术规格 Technical Specification		
催化剂内芯体积 Catalyst Honeycomb Volume (cm <sup>3</sup> )	372.34	
催化剂孔密度 Catalyst Cell Density (cpsi)	300	
贵金属含量 Noble Metals Contents	元素 Element	标称值 Nominal
	Pt (mg)	197.24
	Pd (mg)	0
	Rh (mg)	0
贵金属组成 Noble Metals Composition	Pt/Pd/Rh	1:0:0
贵金属总量 Noble Metals Density	标称值 (g/ft <sup>3</sup> ) Nominal	15
	最小值 (g/ft <sup>3</sup> ) Minimum	13.5
载体外壳材料 Shell Material	SUS444	
内芯材料 Honeycomb Material	0Cr21Al6	
厂家要求标识 Customer Required Identifier	按图纸	
产品编码 DP Code	DP10498	

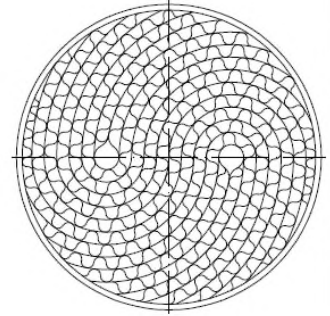
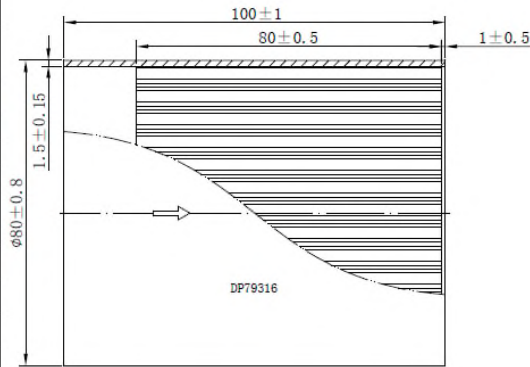

ENGINE TYPE	KD195FC-1, KD195FC, KD192FC, KD192FC-1, KD188FC, KD188FC-1, KD186FC, KD186FC-1
Catalyst	
DRAWING NO.	009



1.3. *Manufacturer's statement on the compliance of the engine type or engine family with the exhaust emission limits use fuels other than the reference fuels*

N/A

1.4. *Overview of the emission control strategy for electronically controlled engines*

N/A

1.5. *The functional operational characteristics of the NOx control measures and inducement system*

N/A

1.6. *The functional operational characteristics of the particulate control measures*

N/A



1.7. *Manufacturer's declaration, and supporting test reports or data, on deterioration factors*

According paragraph 3.2.6.1. Annex III, *Delegated Regulation (EU) 2018/989*, those assigned multiplicative DFs, as given in Table A.3.1. are applied to the following engine family, and we hereby declare that the emission control components (mainly the Diesel Oxidation Catalyst) can reasonably be expected to have the emission durability associated with those assigned factors, this conclusion is based on the durability test of catalyst supplier.

- 1.1. Make (trade name(s) of manufacturer) : KOOP  
1.2. Commercial name(s) (if applicable): : N/A  
1.3. Company name and address of manufacturer : Changzhou Koop Power Machinery Co., Ltd.  
NO.6 Hexiang Road, Wujin Economic Development  
Zone, Changzhou City, Jiangsu Province, China  
1.4. Name and address of manufacturer's authorized representative (if any) : ZIPPER MASCHINEN GMBH  
Gewerbepark 84707 Schlussberg Austria  
1.6. ~~Engine type designation~~/engine family designation/~~FF~~ : Engine family name: KD15  
Parent engine: KD195FC-1  
Engine within family: KD195FC, KD192FC,  
KD192FC-1, KD188FC, KD188FC-1, KD186FC,  
KD186FC-1  
1.7. ~~Category and sub-category of the engine type~~/engine family : Category:NRE  
Sub-category:NRE-v-1  
1.8. Assigned deterioration factors for NRSC and NRTC : CO: 1.3, CH: 1.3, NOx: 1.15, PM: 1.05

Place: Changzhou, Jiangsu

Date: 2021-03-31

Signature: YULEI JIANG



1.8. *Manufacturer's declaration, and supporting test reports or data, of the infrequent regeneration adjustment factors*

N/A



1.9. Declaration by manufacturer on prevention of tampering

The undersigned: YULEI JIANG/ Manager

Hereby declares that the emission control strategies of the following engine type/engine family fitted are designed in such a way as to prevent tampering to the extent possible, as referred to in Article 18(4) of Regulation (EU) 2016/1628 of the European Parliament and of the Council and Annex X of Commission Implementing Regulation (EU) 2018/988.

- 1.1. Make (trade name(s) of manufacturer) : KOOP
- 1.2. Commercial name(s) (if applicable) : N/A
- 1.3. Company name and address of manufacturer : Changzhou Koop Power Machinery Co., Ltd.  
NO.6 Hexiang Road, Wujin Economic Development  
Zone, Changzhou City, Jiangsu Province, China
- 1.4. Name and address of manufacturer's authorized representative (if any) : ZIPPER MASCHINEN GMBH  
Gewerbepark 84707 Schlusberg Austria
- 1.6. ~~Engine type designation/engine family designation/ET~~ : Engine family name: KD15  
Parent engine: KD195FC-1  
Engine within family: KD195FC, KD192FC,  
KD192FC-1, KD188FC, KD188FC-1, KD186FC,  
KD186FC-1

Place: Changzhou, Jiangsu

Date: 2021-03-31

Signature: YULEI JIANG



Appendix 1: Technical details

For Injection timing adjustment, it is not easily to be adjusted by common tools, the screw should be adjusted by special tools.

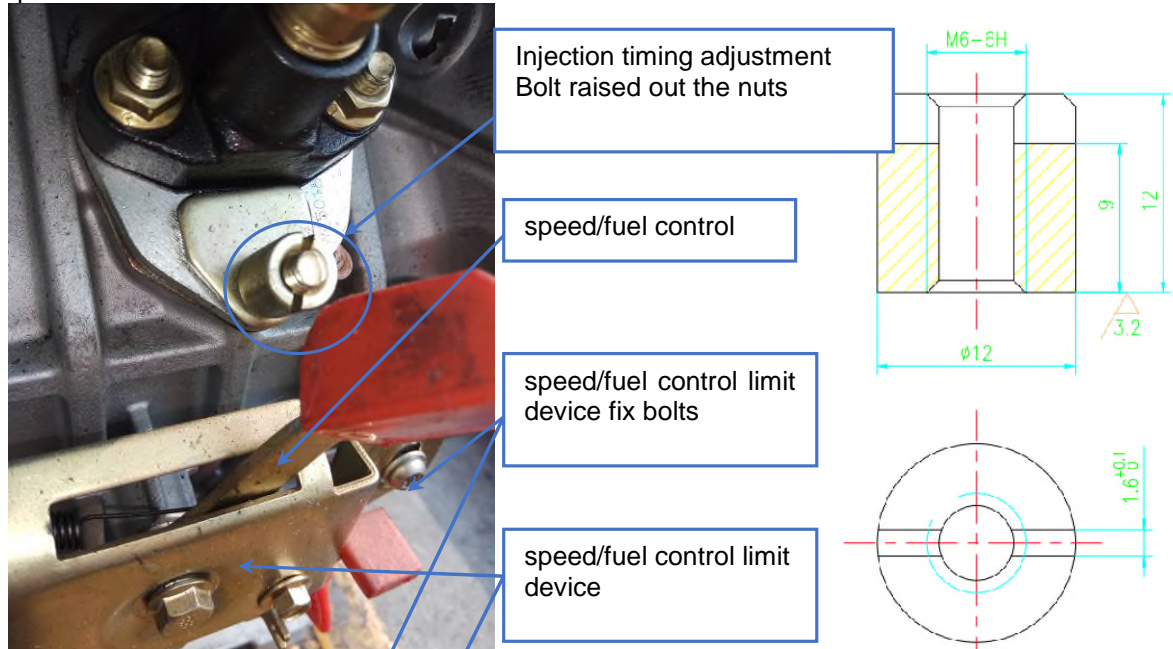

For speed/fuel control, the bolt head is sealed by transparent permanent glue after adjusted by the manufacturer.

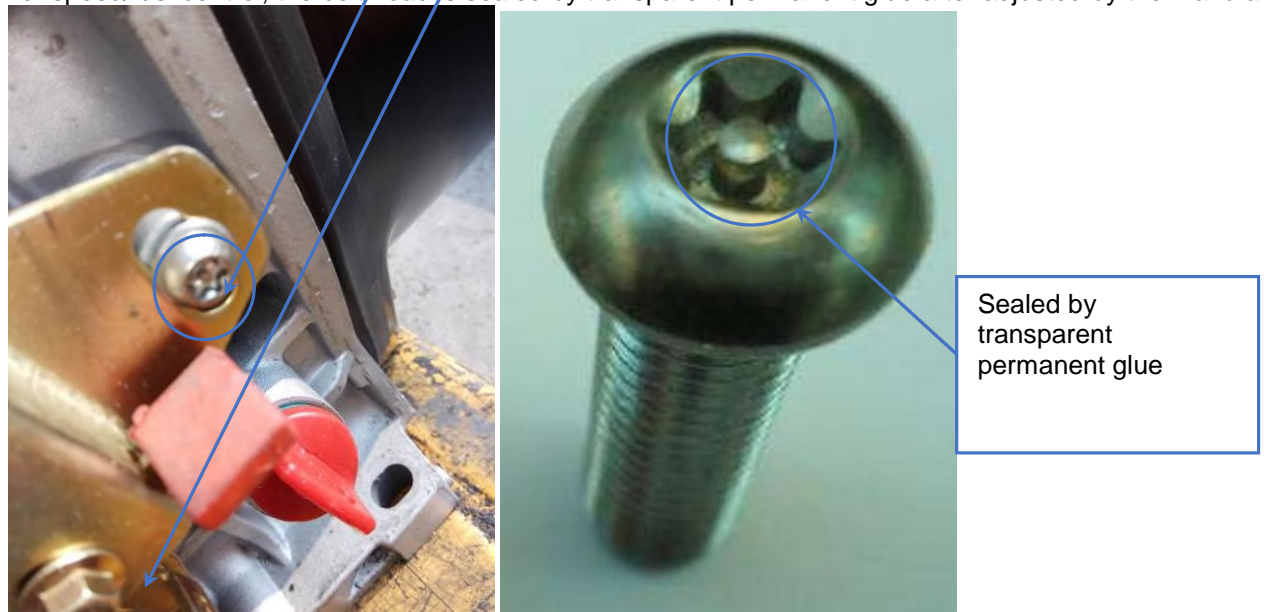

*1.10 The physical connector required to receive the torque signal from the engine Electronic control Unit (ECU) during the in-service monitoring test*

N/A



1.11 A list of scheduled emission-related maintenance requirements and the period at which each should occur including any scheduled exchange of critical emission-related components

Proper maintenance is essential for safe, economical and trouble-free operation. It also helps reduce air pollution. In order to keep your gasoline engine in good working condition, it must be periodically serviced. The following maintenance schedule and routine inspection procedures must be carefully followed.

Interval of maintenance Item	Everyday	1st month or after 20 hours	3rd month or 100 hours	6th month or 500 hours	Every year or 1000 hours
Check and fill enough fuel	○				
Discharge fuel		○			
Check and fill enough engine oil	○				
Check whether it leaks oil	○				
Check and screw each fastened part	○			● Screw the bolt of cylinder head firmly)	
Exchange engine oil		○ (1st time)	○ (2nd time late)		
Clean filter of engine oil				○ (Exchange)	
Exchange air filter element	If operated at dusty region, the period of maintenance should be shorten)			○ (Exchange)	
Clean filter of fuel				○	● (Exchange)
Check high pressure oil pump				●	
Check nozzle				●	
Check fuel pipe				● (If necessary, exchange it)	
Adjust the gaps of air intake and air exhausted gate		● (1st time)		●	
Grind air intake and air exhausted gate					●
Exchange piston ring					●
Check electrolytic solution of accumulator	(each month)				
Check electric brush and slide ring				●	
Check insulation resistance	The time of stop is over 10 days.				○

Note: “ ● ” mark indicates that it needs special wrench, please contact with dealer.



